



Service Repair Manual

Models

627G Wheel Scraper

Product: WHEEL SCRAPER

Model: 627G WHEEL SCRAPER CEZ

Configuration: 627G Wheel Scraper CEZ00001-UP (MACHINE) POWERED BY C-9 Engine

Disassembly and Assembly 627G Wheel Scraper Power Train

Media Number -REN4232-02

Publication Date -01/03/2004

Date Updated -09/03/2018

i04332691

Torque Converter - Disassemble

SMCS - 3101-015

Disassembly Procedure

Table 1

Required Tools			
Tool	Part Number	Part Description	Qty
A	138-7575	Link Bracket	3
B	1P-1861	Retaining Ring Pliers	1
C	1P-0520	Driver Gp	1
D	2P-8312	Retaining Ring Pliers (External)	1
E	8H-0663	Bearing Puller Gp (Nine Ton Capacity)	1
F	1P-2322	Combination Puller (Two Jaw or Three Jaw)	1
	1P-0546	Puller Jaw	1
	1P-0510	Driver Gp	1

Start By:

- a. Separate the torque converter from the transmission. Refer to Disassembly and Assembly, "Torque Converter, Transmission and Transfer Gear - Separate".

NOTICE

Care must be taken to ensure that fluids are contained during performance of inspection, maintenance, testing, adjusting, and repair of the product. Be prepared to collect the fluid with suitable containers before opening any compartment or disassembling any component containing fluids.

Refer to Special Publication, NENG2500, "Dealer Service Tool Catalog" for tools and supplies suitable to collect and contain fluids on Cat products.

Dispose of all fluids according to local regulations and mandates.

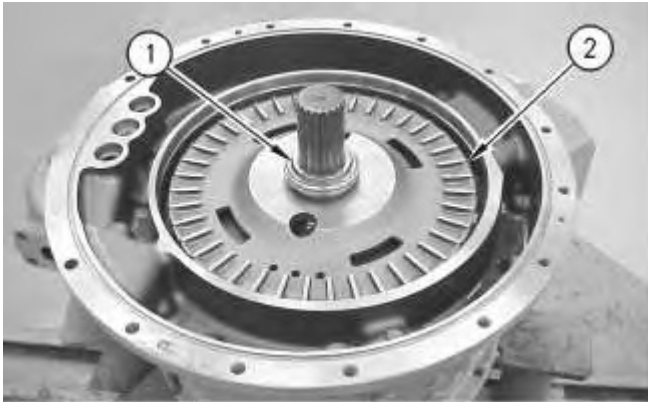

Illustration 1

g00833596

1. Remove retaining ring (1). Remove retarder rotor (2).
-

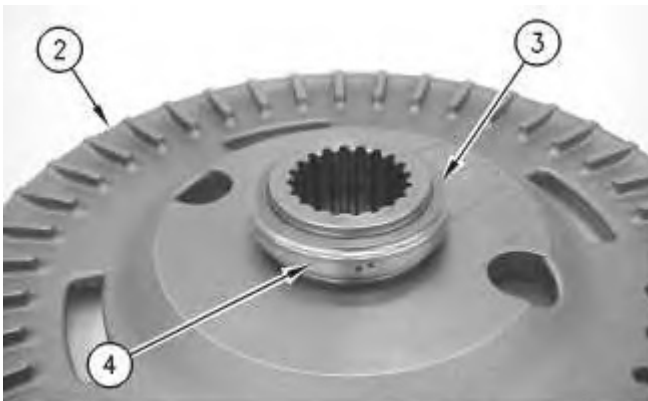

Illustration 2

g00833624

2. Remove seal ring (4) from carrier (3) on each side of retarder rotor (2).
3. Remove carrier (3).

Note: The carrier will be destroyed when the carrier is removed from the retarder.

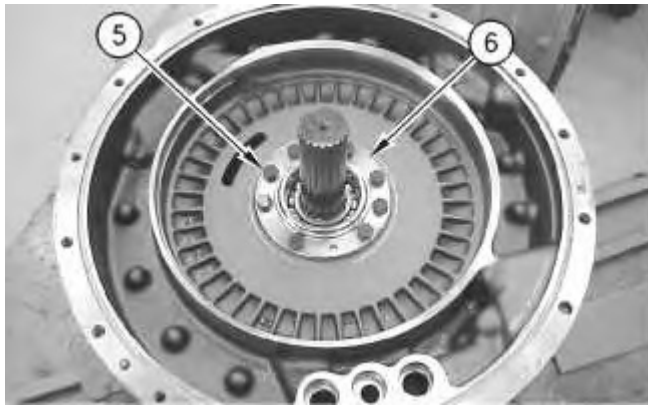

Illustration 3

g00833629

4. Remove bolts (5). Remove race (6).



Illustration 4

g00833647

5. Attach Tooling (A) and a suitable lifting device to housing assembly (7). The weight of housing assembly (7) is approximately 73 kg (160 lb).
6. Remove housing assembly (7) from the torque converter.



Illustration 5

g00833655

7. Position housing assembly (7), as shown.

8. Remove bolts (9). Remove gear (8).



Illustration 6

g00833666

9. Use Tooling (B) to remove retaining ring (10) from each side of gear (8).



Illustration 7

g00833676

10. Remove shaft (11).



Illustration 8

g00833678

11. Use a suitable press and Tooling (C) to remove the bearing from gear (8).

Thank you so much for reading.
Please click the “Buy Now!”
button below to download the
complete manual.



After you pay.

You can download the most
perfect and complete manual in
the world immediately.

Our support email:

ebooklibonline@outlook.com