

Product: EXCAVATOR

Model: 538 EXCAVATOR KBJ

Configuration: 538 Forest Machine General Forestry KBJ00001-UP (MACHINE) POWERED BY C7.1 Engine

Disassembly and Assembly 538 LL GF Forest Machine Machine Systems

Media Number -M0071454-01

Publication Date -01/08/2017

Date Updated -02/08/2017

i06724515

Swivel - Disassemble

SMCS - 5060-015

Disassembly Procedure

Table 1

Required Tools			
Tool	Part Number	Part Description	Qty
A	1P-2420	Transmission Repair Stand	1
B	439-3940	Bracket As	2

Start By:

- a. Remove the swivel.

NOTICE

Keep all parts clean from contaminants.

Contaminants may cause rapid wear and shortened component life.

Note: Put orientation and location marks on housings for installation purposes.

1. Thoroughly clean the outside of the swivel prior to disassembly.
-

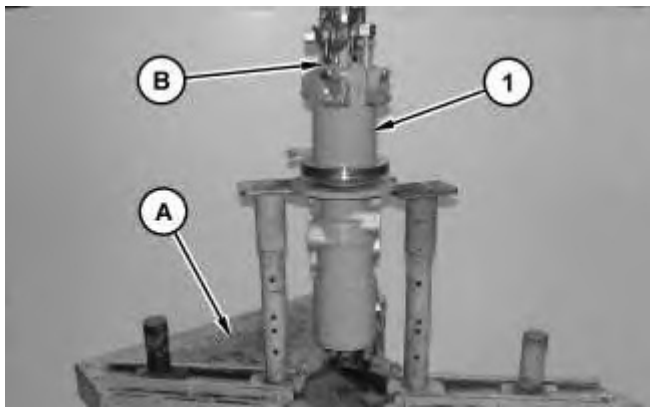

Illustration 1

g01767936

2. Attach Tooling (B) and a suitable lifting device to swivel (1). The weight of swivel (1) is approximately 496 kg (225 lb).
3. Position swivel (1) onto Tooling (A).

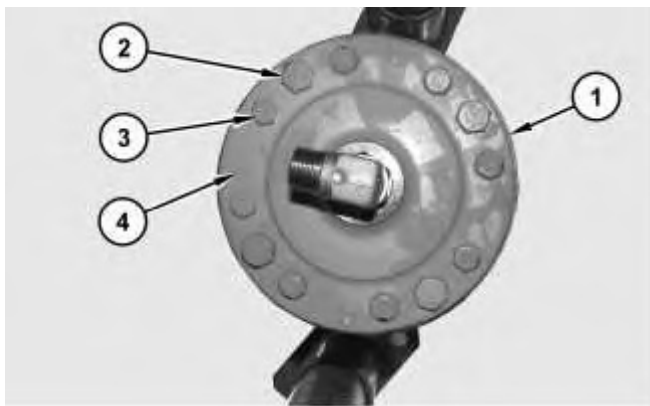

Illustration 2

g01768234

4. Remove bolts (2) and (3).
5. Remove cover (4) from the bottom of swivel (1).

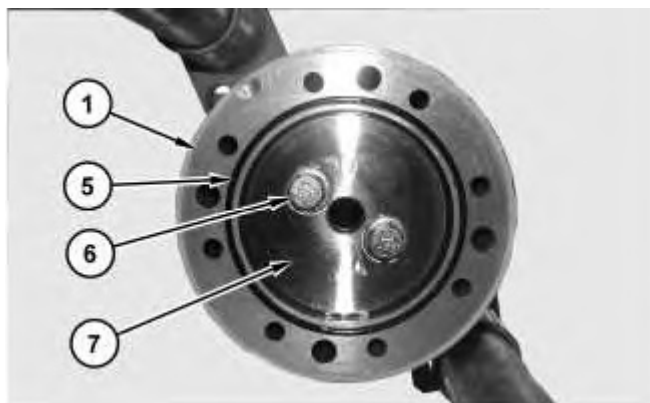

Illustration 3

g01768296

6. Remove O-ring seal (5), bolts (6), and retainer (7) from the bottom of swivel (1).

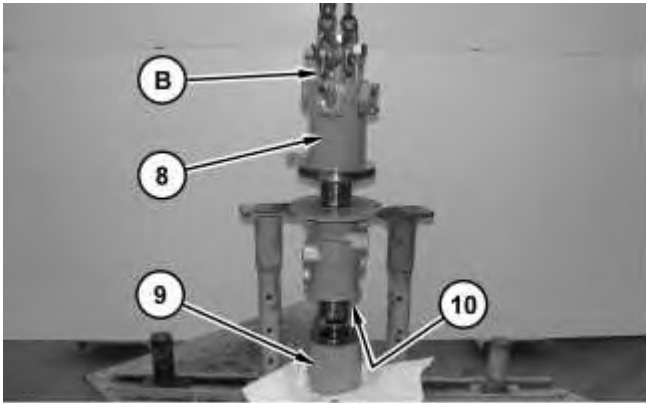

Illustration 4

g01768395

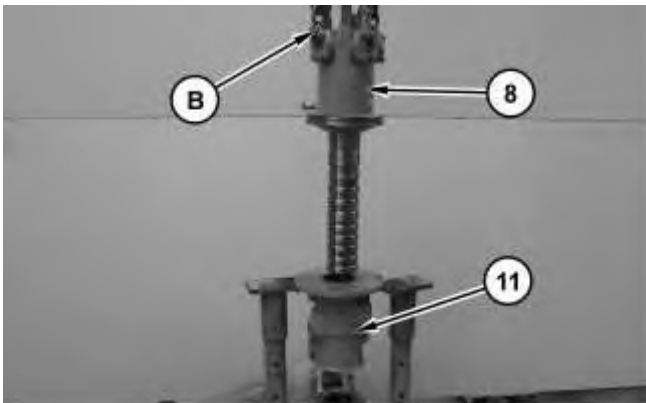

Illustration 5

g01768497

Note: Be sure that alignment marks are put on rotor (8) and housing (11) for assembly purposes.

7. Use Tooling (B) and a suitable lifting device to separate rotor (8) from housing (9).
8. Remove O-ring seal (10) (not shown) from housing (11).
9. Use Tooling (B) and a suitable lifting device to separate rotor (8) from housing (11).



10. Remove seal assemblies (12) from housing (11).

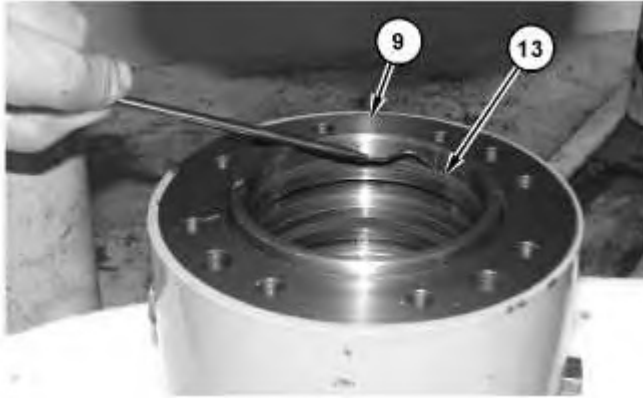

11. Remove seal assemblies (13) from housing (9).

Product: EXCAVATOR

Model: 538 EXCAVATOR KBJ

Configuration: 538 Forest Machine General Forestry KBJ00001-UP (MACHINE) POWERED BY C7.1 Engine

Disassembly and Assembly 538 LL GF Forest Machine Machine Systems

Media Number -M0071454-01

Publication Date -01/08/2017

Date Updated -02/08/2017

i06724539

Swivel - Assemble

SMCS - 5060-016

Assembly Procedure

Table 1

Required Tools			
Tool	Part Number	Part Description	Qty
A	1P-2420	Transmission Repair Stand	1
B	439-3940	Bracket As	2

NOTICE

Keep all parts clean from contaminants.

Contaminants may cause rapid wear and shortened component life.

Note: Check the O-ring seals and the seals for wear or for damage. Replace the components, if necessary.



Illustration 1

g01768813

1. Apply clean hydraulic oil to seal assemblies (12).
2. Install O-ring seal (10) and seal assemblies (12) into housing (11).



Illustration 2

g01768833

3. Position housing (9) onto housing (11). Loosely install bolts (2) to secure housing (9) to housing (11).
4. Apply clean hydraulic oil to seal assemblies (13).
5. Install seal assemblies (13) into housing (9).

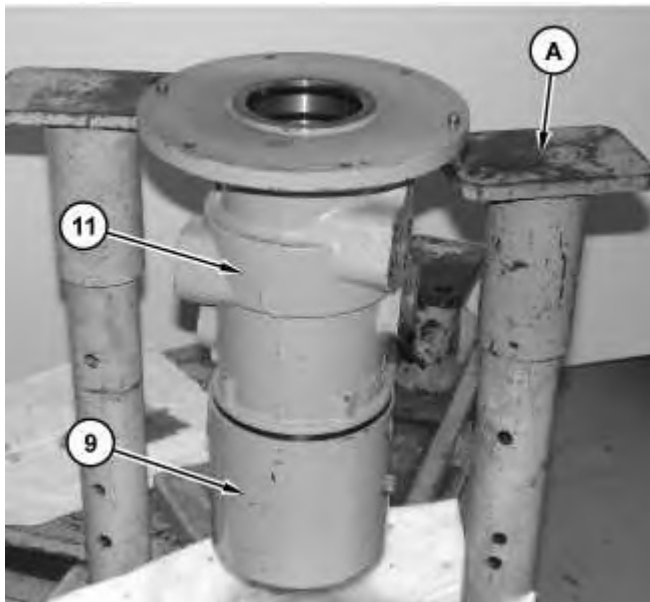

Illustration 3

g01769453

6. Use two people to position housing (9) and housing (11) onto Tooling (A). The combined weight of housing (9) and housing (11) is approximately 41 kg (91 lb).

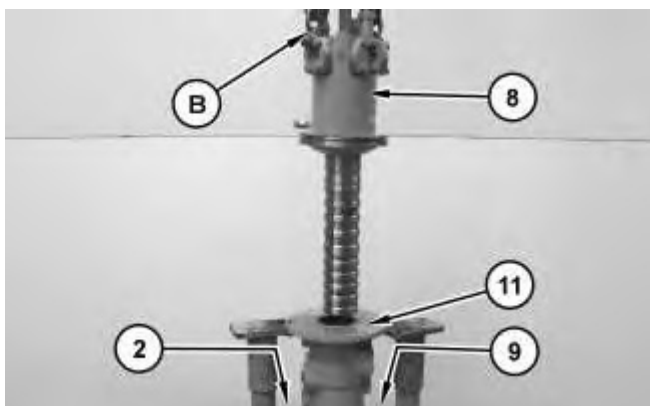

Illustration 4

g01769537

7. Attach Tooling (B) and a suitable lifting device to rotor (8). The weight of rotor (8) is approximately 54 kg (119 lb).
8. Use Tooling (B) and a suitable lifting device to install rotor (8) into housing (11) and housing (9) (not shown).
9. Remove four bolts (2) (not shown).

Thank you so much for reading.
Please click the “Buy Now!”
button below to download the
complete manual.



After you pay.

You can download the most
perfect and complete manual in
the world immediately.

Our support email:

ebooklibonline@outlook.com