



Service Repair Manual

Models

C9 Industrial Engine

Product: INDUSTRIAL ENGINE
Model: C9 INDUSTRIAL ENGINE JLW
Configuration: C9 Industrial Engine JLW00001-UP

Disassembly and Assembly C9 Industrial Engines

Media Number -REN7460-07

Publication Date -01/07/2014

Date Updated -15/11/2017

i02539716

Engine Oil Filter Base and Oil Cooler - Remove

SMCS - 1306-011; 1378-012

Removal Procedure

Table 1

Required Tools			
Tool	Part Number	Part Description	Qty
A	185-3630	Strap Wrench Assembly	1

NOTICE

Keep all parts clean from contaminants.

Contaminants may cause rapid wear and shortened component life.

NOTICE

Care must be taken to ensure that fluids are contained during performance of inspection, maintenance, testing, adjusting, and repair of the product. Be prepared to collect the fluid with suitable containers before opening any compartment or disassembling any component containing fluids.

Refer to Special Publication, NENG2500, "Dealer Service Tool Catalog" for tools and supplies suitable to collect and contain fluids on Cat[®] products.

Dispose of all fluids according to local regulations and mandates.

1. Drain the coolant from the cooling system into a suitable container for storage or for disposal. Refer to Operation and Maintenance Manual, "Cooling System Coolant - Change".
-

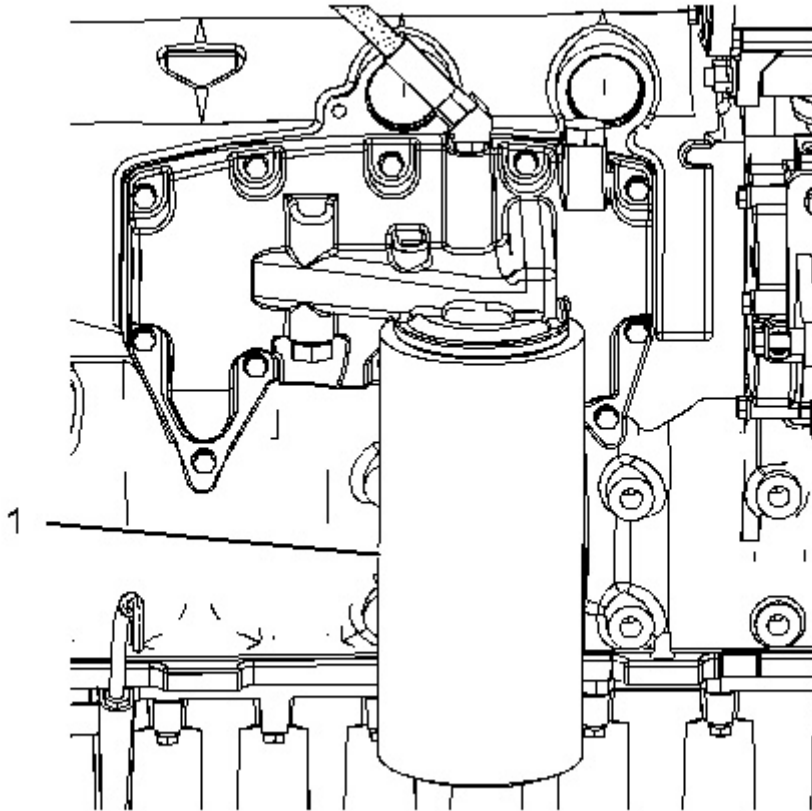

Illustration 1

g01171123

2. Use Tooling (A) to remove engine oil filter (1).
-

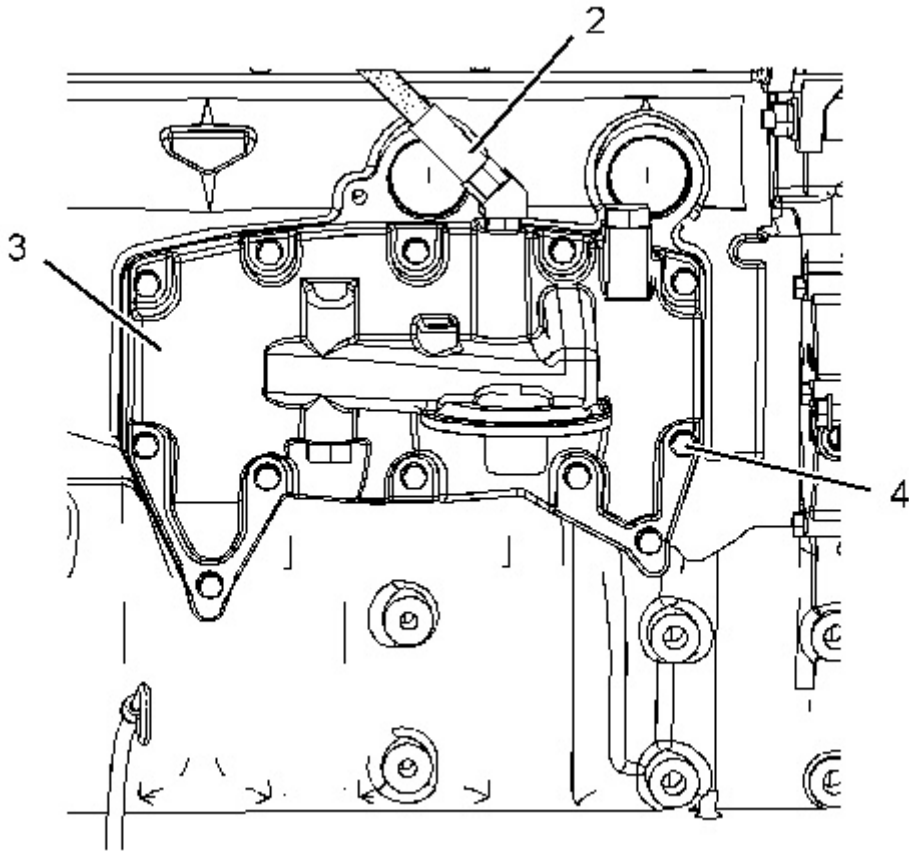

Illustration 2

g01271362

3. Disconnect hose assembly (2). Remove bolts (4). Remove engine oil filter base (3) and the oil seal.
-

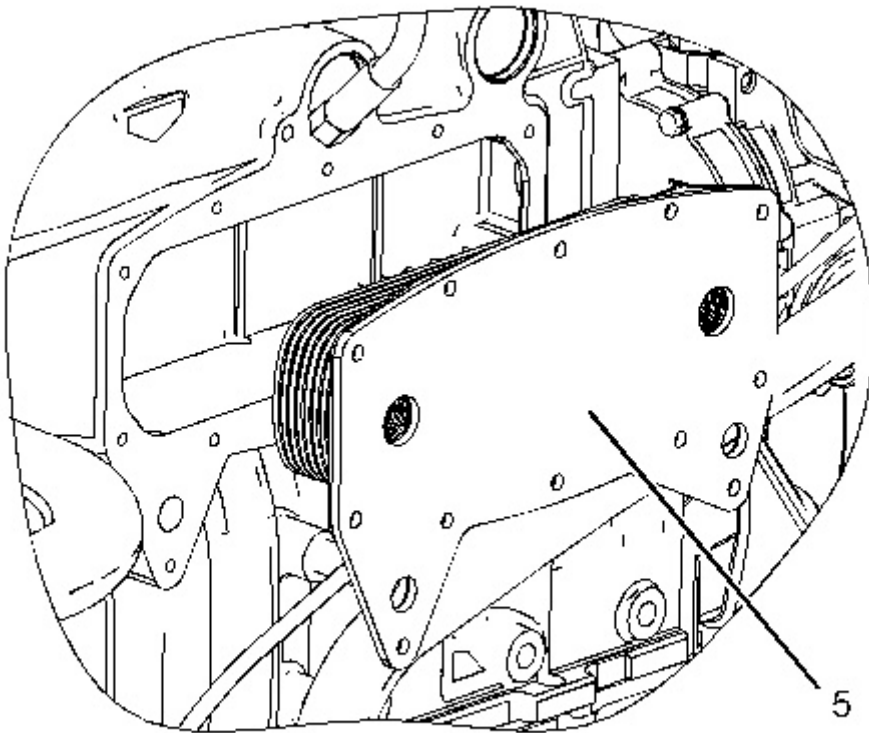

Illustration 3

g01150963

4. Remove engine oil cooler (5) and the gasket.

Product: INDUSTRIAL ENGINE
Model: C9 INDUSTRIAL ENGINE JLW
Configuration: C9 Industrial Engine JLW00001-UP

Disassembly and Assembly C9 Industrial Engines

Media Number -REN7460-07

Publication Date -01/07/2014

Date Updated -15/11/2017

i02539755

Engine Oil Filter Base and Oil Cooler - Install

SMCS - 1306-012; 1378-012

Installation Procedure

NOTICE

Keep all parts clean from contaminants.

Contaminants may cause rapid wear and shortened component life.

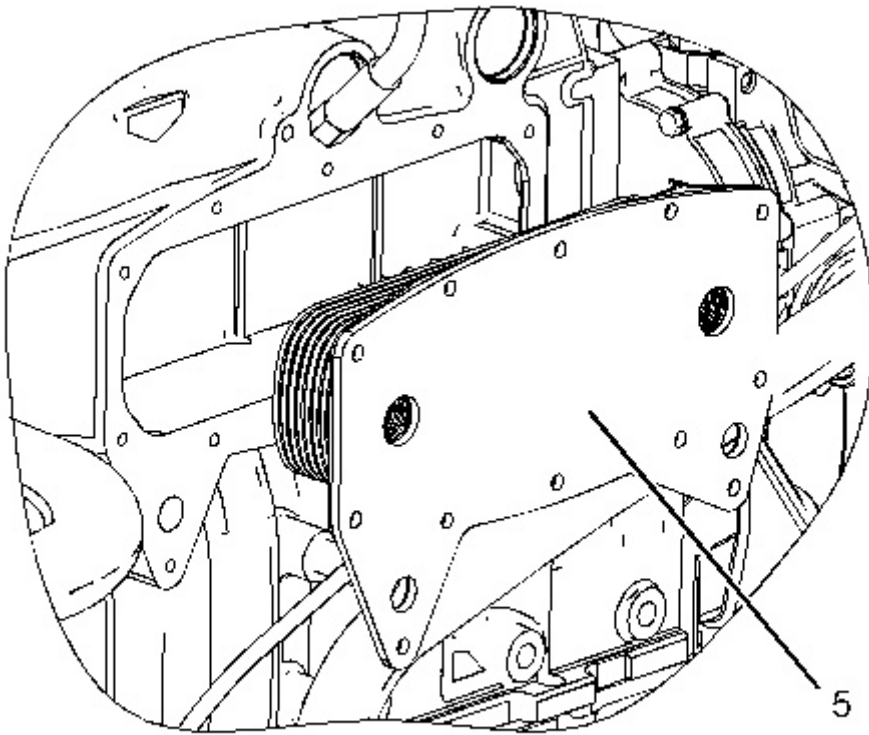

Illustration 1

g01150963

1. Install the gasket and engine oil cooler (5).
-

Thank you so much for reading.
Please click the “Buy Now!”
button below to download the
complete manual.



After you pay.

You can download the most
perfect and complete manual in
the world immediately.

Our support email:

ebooklibonline@outlook.com