

Tools Needed		A	B	C	D	E	F
9S8901	Cylinder Group	1					
9U6600	Pump Group	1				1	
1U6415	Puller Assembly	1					
5F9306	Arm	3					
6H4168	Pin	3					
7B2499	Ring	6					
7M9773	Adapter	1					
7M9774	Coupling	1					
3P2248	Adapter	1					
5F9892	Pin	1					
7S7112	Pin	1					
8B7548	Puller Assembly		1				
8B7554	Bearing Cup Puller		1				
7F9306	Spanner Wrench			1			
2B2003	Yoke				1		
6V3123	Adapter					1	
6V3124	Nut					3	
5P5207	Stud					1	
6V4000	Head					1	
6V3126	Pin					6	
6V3125	Arm					3	
5P5208	Nut					1	
5P6222	Adapter					1	
5P5201	Cylinder					1	
6V3127	Lock					12	
8B7560	Step Plate						1
1H3112	Bearing Cup Puller						1
5F7379	Bolt						1
1P0492	Drive Plate						1

START BY

a) remove track roller frames

1. Drain the oil from the final drive case.

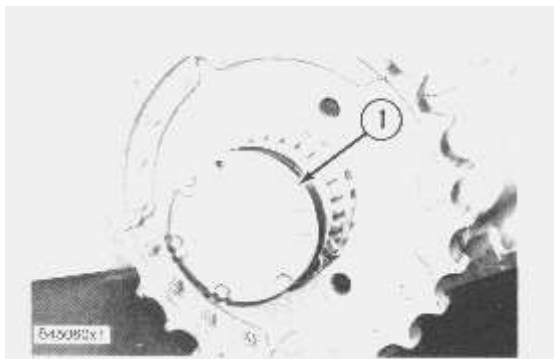

2. Remove cap (1) and the gasket.

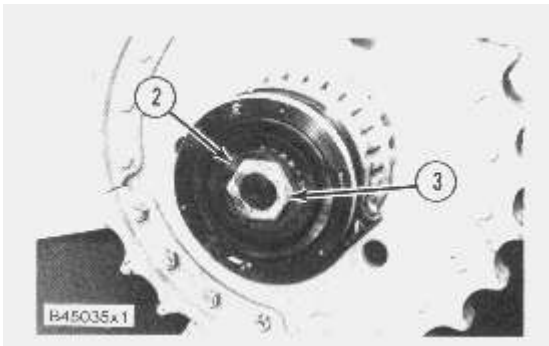

3. Remove lock (2) and nut (3) from the sprocket shaft.

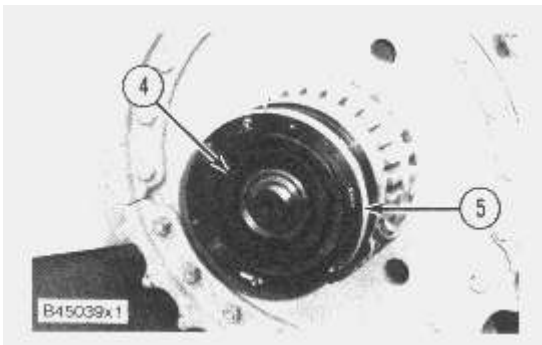

4. Remove retainer (4) and the shims from the sprocket shaft.

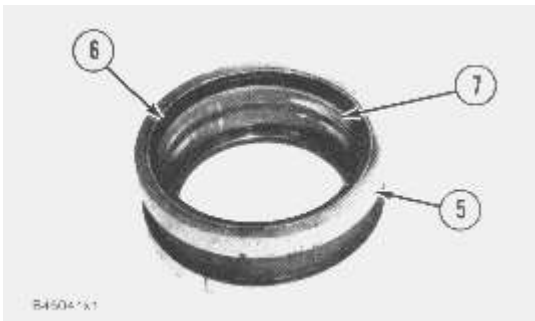

5. Remove support (5) from the holder assembly. Remove the seal ring from the holder assembly.

6. Remove seal (6) and bearing (7) from support (5).

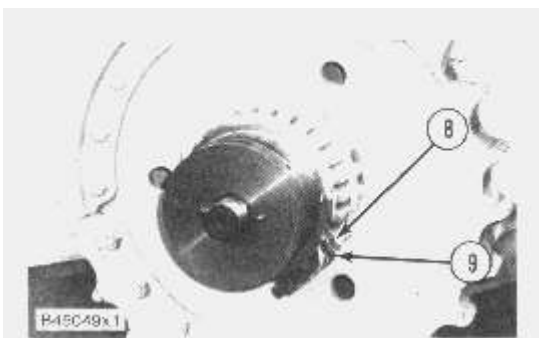

7. Remove the nut and bolt (8). Remove lock (9) from the holder assembly.

NOTICE

Do not use more than 50 ton (445 kn) of pressure to remove the holder assembly.

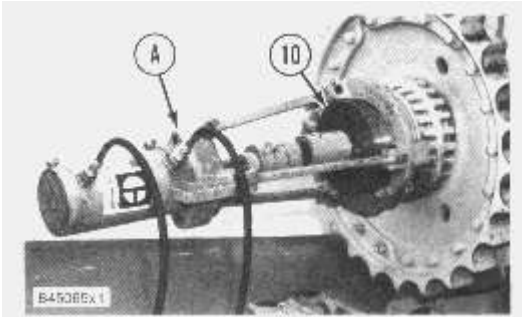

8. Install tooling (A) as shown and loosen holder assembly (10) from the taper on the sprocket shaft.

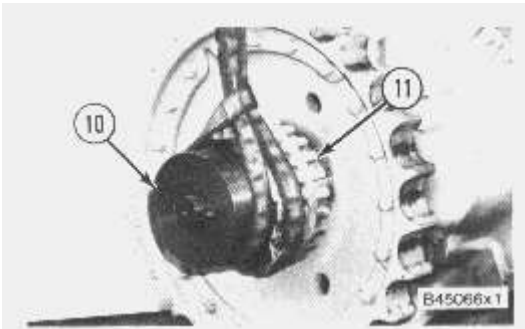

9. Remove tooling (A). Fasten a hoist and remove holder assembly (10) and adjusting nut (11) as a unit. The weight is approximately 80 lb. (36 kg.).

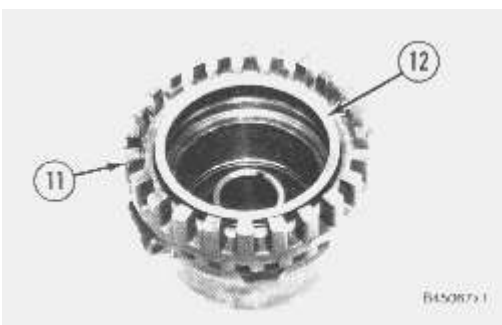

10. Remove Duo-Cone seal (12) from adjusting nut (11).

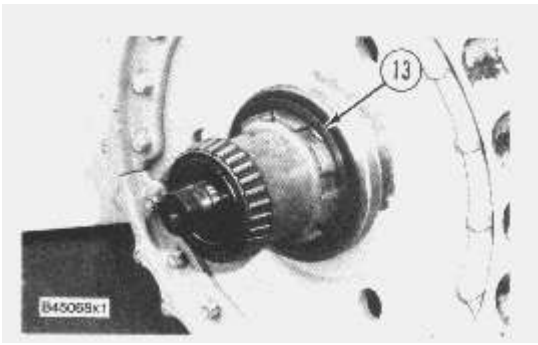

11. Remove Duo-Cone seal (13) from the sprocket.

NOTE: Keep the Duo-Cone seals for the sprocket and adjuster nut together so they will not be mixed at assembly.

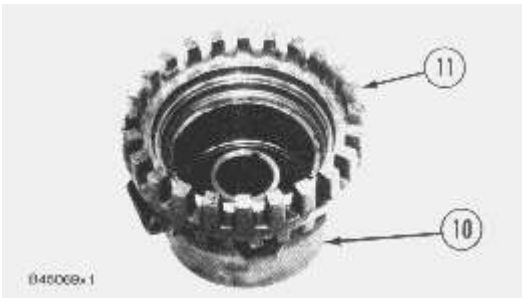

12. Remove adjusting nut (11) from holder assembly (10).

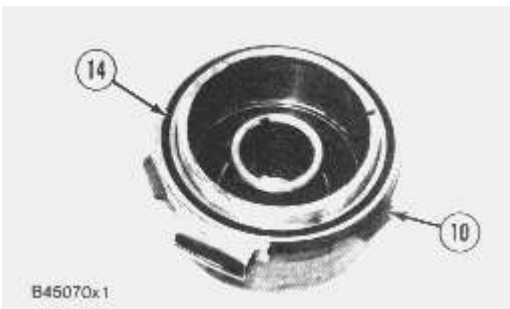

13. Remove gasket (14) from holder assembly (10).

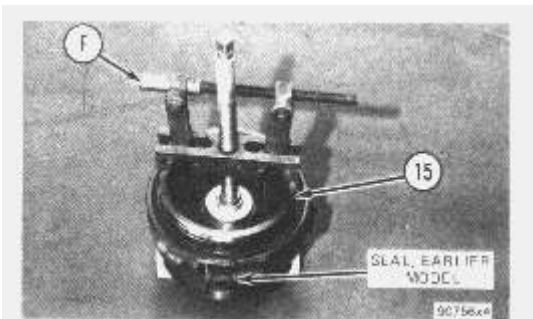

NOTE: Do Steps 14 and 15 for earlier models only.

14. Remove the seal from the holder. See illustration 90756X4.



15. Remove cage (15) from the holder with tooling (F) as shown.

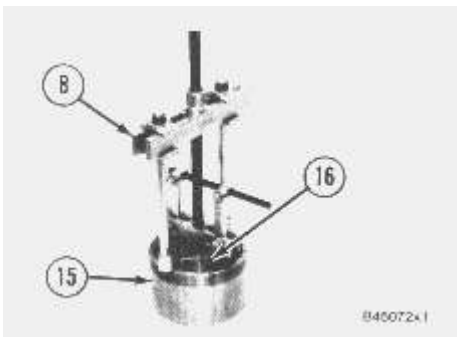

NOTE: Do Step 16 for later models only.

16. Remove cage (15) from the holder.

17. Remove bearing cup (16) from cage (15) with tooling (B).

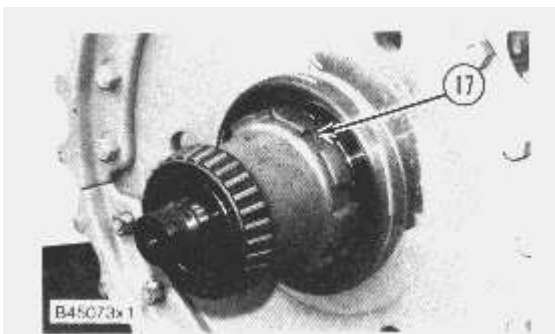

18. Bend lock (17) down.

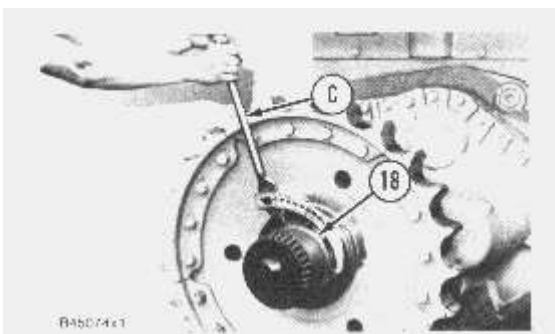

19. Remove bearing cone (18) as follows:

a) Loosen nut (18) with tool (C) until there is a distance of 1 in. (25.4 mm) between the nut and the sprocket.

b) Remove tool (C) from the nut.

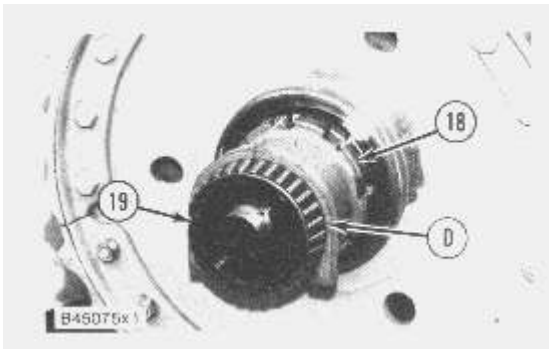

c) Turn nut (18) in until tool (D) can be installed between bearing cone (18) and nut (17).

d) Remove bearing cone (19), nut (18) and lock from the sprocket shaft.

20. Remove the key from the sprocket shaft.



The sprocket is installed on the hub with a force of 60 to 65 tons (535 to 580 kN). Keep away from the area of the sprocket when it is loosened from the hub with tooling (E).

21. Assemble tooling (E) and remove the sprocket as follows:

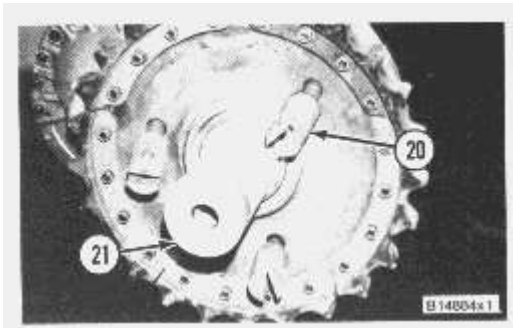

a) Put 5P6222 Adapter (21) on the hub assembly. Turn the adapter until it is .25 in. (0.64 mm) from the sprocket hub. Put 6V3123 Adapters (20) in the puller holes for the sprocket. Use the 6V3124 Nuts to hold adapters (20) in position. Install each nut so the flat end of the nut is even with the end of the threads on the adapter and the drill point is toward the outside diameter of the sprocket. The angle face of the nut must be toward the sprocket.

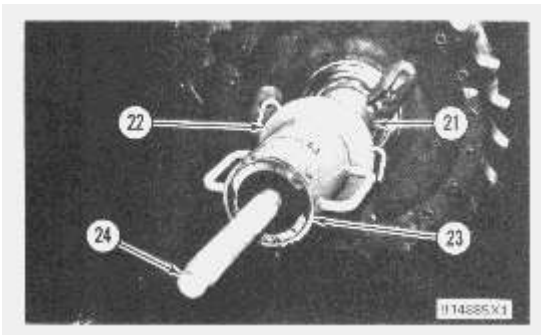

b) Install 5P5207 Stud (22) in 5P6222 Adapter (21). Slide 5P5212 Plate Assembly (22) and 5P5201 Cylinder (23) with the piston end away from the sprocket over stud (24) and against adapter (21).

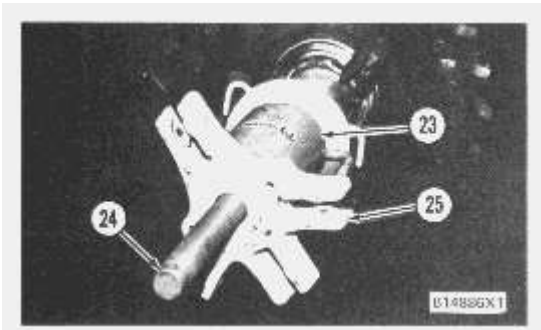

c) Put 6V4000 Head (25) on stud (24) so the flat side of the head is toward cylinder (23).

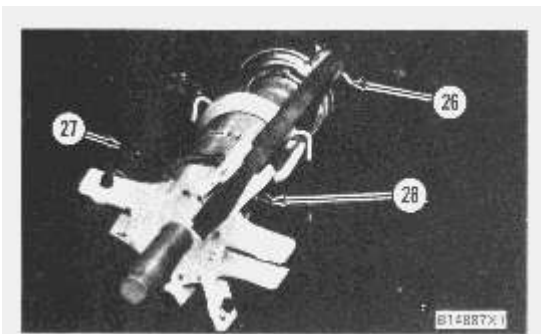

d) Put 6V3125 Arms (27) in position in the head and the adapters and install 6V3126 Pins (26) and 6V3127 Locks (28).

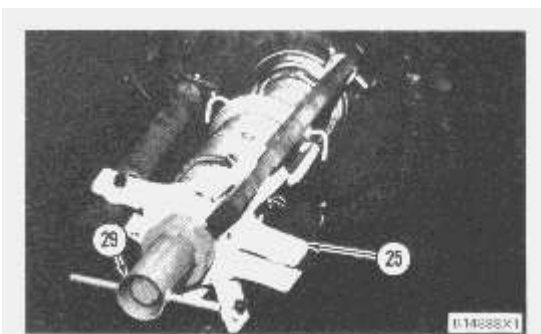

e) Put 5P5208 Nut (29) on stud (24) until it is 1 in. (25.4 mm) from head (25). Use tooling (E) to loosen the sprocket from the hub.

Thank you so much for reading.
Please click the “Buy Now!”
button below to download the
complete manual.



After you pay.

You can download the most
perfect and complete manual in
the world immediately.

Our support email:

ebooklibonline@outlook.com