

Product: TRACK LOADER

Model: 953 TRACK LOADER 77Y

Configuration: 953 TRACK LOADER / HIGH DRIVE / 77Y01093-UP (MACHINE) POWERED BY 3204 ENGINE

Disassembly and Assembly

3204 VEHICULAR ENGINE FOR 943 & 953 TRACK-TYPE LOADERS

Media Number -SEN4214-00

Publication Date -01/04/1985

Date Updated -11/10/2001

Governor (Interim Scroll Fuel System)

SMCS - 1264-015; 1264-016

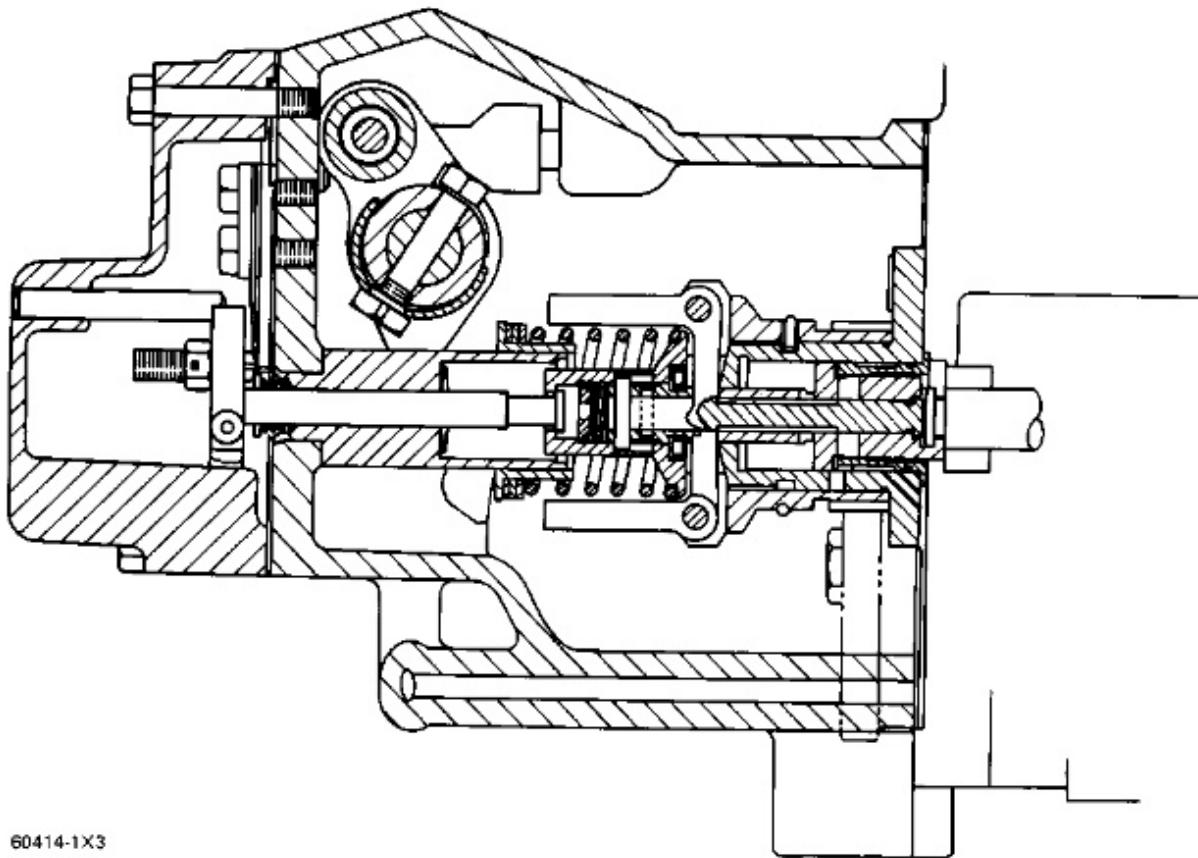

Disassemble Governor (Interim Scroll Fuel System)

Tools Needed		A
1P510	Driver Group	1

START BY:

a. remove fuel injection pump housing and governor (interim scroll fuel system)

NOTE: If it is desired to only remove the governor so the fuel injection pump housing can be disassembled, do only Steps 1, 3, 5, 6, 12 and 13.



1. Remove cover (1).

2. Remove lever (2) and the key from the shaft.

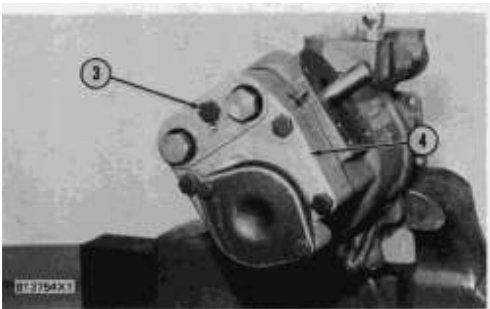

3. Remove bolts (3) and cover (4) from the governor housing.

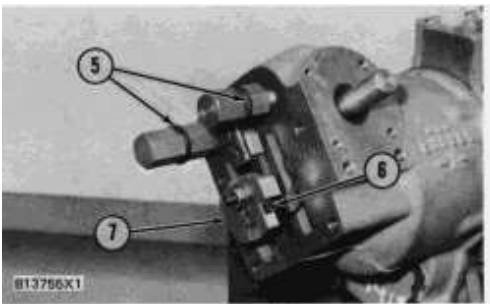

4. Remove O-ring seals (5) from the low and high idle adjustment screws.

5. Remove screw (6) from rack stop collar (7), and remove collar (7). Remove the spring from behind the collar.

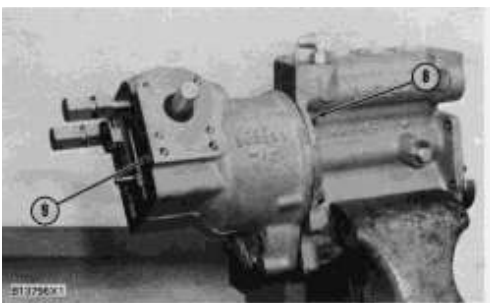

6. Remove bolts (8), and remove governor housing (9) from the fuel injection pump housing.

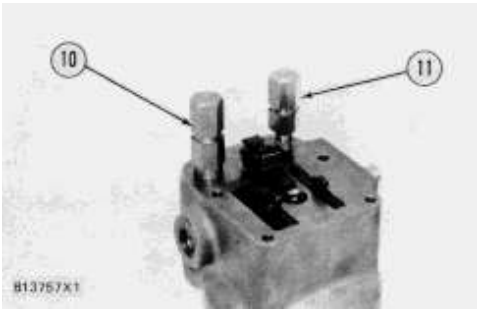

7. Remove high idle adjustment screw (11) and low idle adjustment screw (10) from the governor housing. Remove the high idle adjustment screw first.

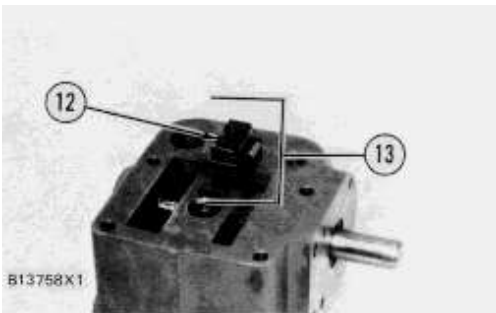

8. Remove bolts (12) and torque control (13) from the governor housing.

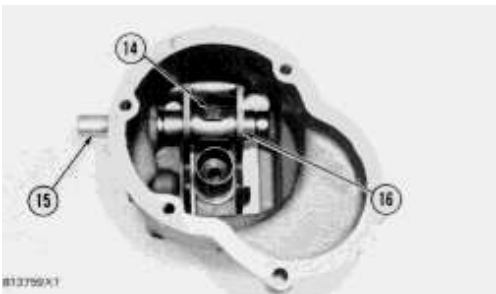

9. Remove bolt (14) and the lock. Remove shaft (15) and lever assembly (16) from the governor housing.

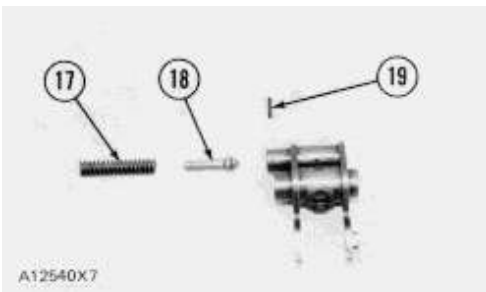

! WARNING

Pin (19) holds spring (17) in compression. Use caution to prevent injury when pin (19) is removed. Release the tension in spring (17) slowly.

10. Remove pin (19), spring (17) and plunger (18) from the lever assembly.

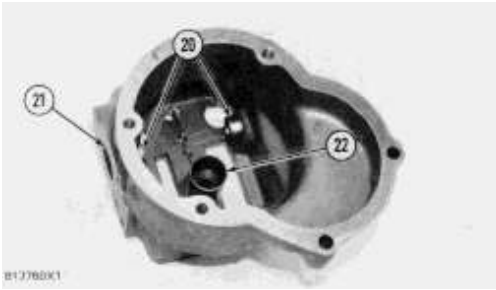

11. Remove seal (21) from the governor housing. Use tooling (A) to remove the plug and bearings (20) from the governor housing.

NOTE: If a replacement of spring guide (22) is necessary, see Special Instruction, Form No. SMHS7356 - Use Of 6V22 Tool Group For Replacement Of Governor Spring Guide.

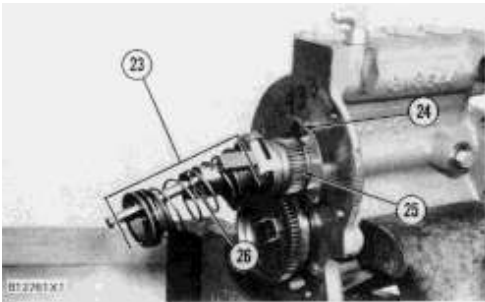

12. Remove seat, washer, wave-washers and governor spring (23) from the weight assembly. Remove spring washer (26) from the weight assembly.

13. Remove bolts (24) and the lock that hold weight assembly (25) to the fuel injection pump housing. Pull the weight assembly out and to the side to disengage it from the rack.

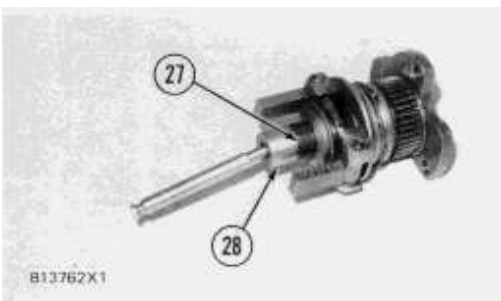

14. Remove ring (27) and the dowel under the ring that holds seat (28) in place.

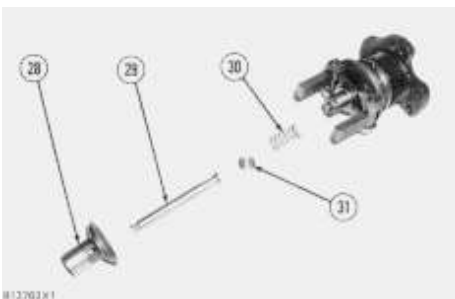

15. Remove seat (28), bolt (29) and spring (30) from the weight assembly. Remove washer (31) from spring (30).



16. Remove guide (32), the two races and bearing from the sleeve.



17. Remove the second dowel (33) that holds sleeve (34) in place, and remove the sleeve.

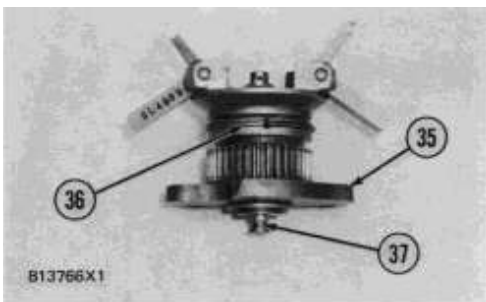

18. Remove valve (37) from the weight assembly and cylinder (35).

19. Remove lock (36), and separate the weight assembly and cylinder (35).

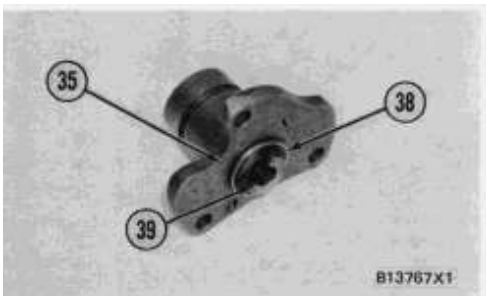

20. Remove sleeve (38) and piston (39) from cylinder (35). Remove the O-ring seal from the sleeve.

Assemble Governor (Interim Scroll Fuel System)

Tools Needed		A
1P510	Driver Group	1

NOTE: Put clean oil on all parts before assembly and be sure all oil passages are clear.

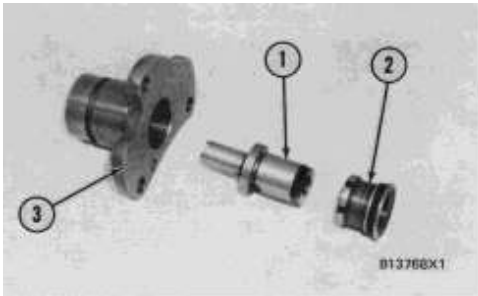

1. Install the O-ring seal on sleeve (2). Install piston (1) in sleeve (2). Install sleeve (2) in cylinder (3).



2. Install cylinder (3) in weight assembly (4), and install lock (5) to hold them together.

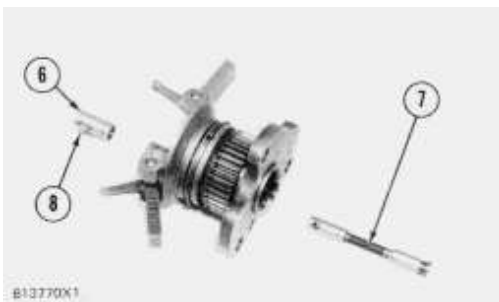

3. Install valve (7) through the cylinder, and install sleeve (6) on the valve with the second hole in the sleeve in alignment with the hole in the valve. Install dowel (8) to hold the sleeve on the valve.

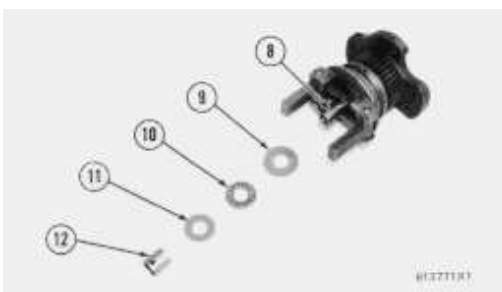

4. Install larger race (9), bearing (10), smaller race (11) and guide (12) on sleeve (8). Put the hole in guide (12) in alignment with the first hole in sleeve (8).

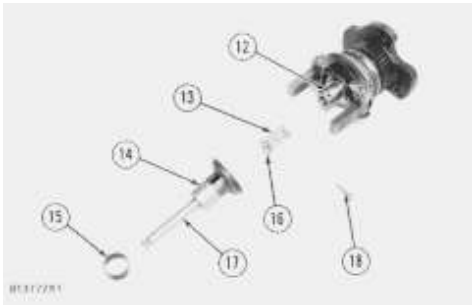

5. Install washer (16) in spring (13). Install bolt (17) in seat (14). Put spring (13) and seat (14) in position on guide (12) with the hole in seat (14) in alignment with the hole in guide (12). Install dowel (18) through seat (14) and guide (12). Install ring (15) on the seat to hold the dowel in place.

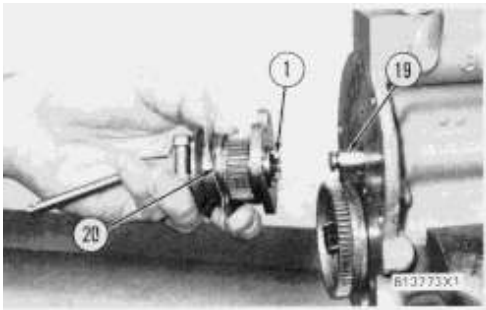

6. Install the weight assembly on the fuel injection pump housing with piston (1) engaged over the groove in rack (19). Install lock (20) and the bolts that hold the weight assembly to the fuel injection pump housing.

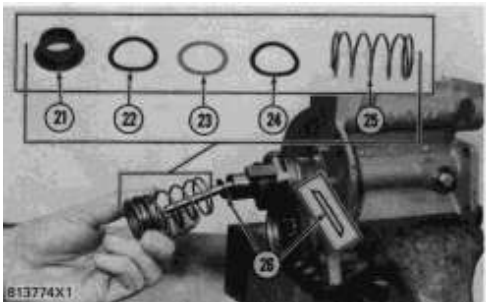

7. Install spring washer (26) on the bolt as shown.

8. Install spring (25), one wave washer (24), flat washer (23), other wave washer (22) and seat (21) on the bolt as shown.

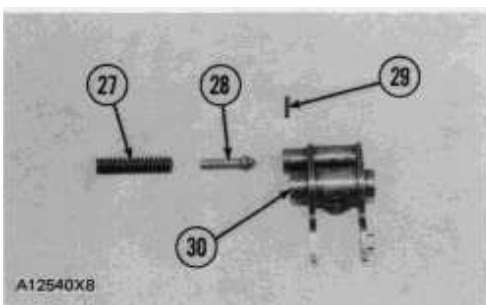

Thank you so much for reading.
Please click the “Buy Now!”
button below to download the
complete manual.



After you pay.

You can download the most
perfect and complete manual in
the world immediately.

Our support email:

ebooklibonline@outlook.com