

Product: WATER FORDING TRACTOR

Model: D7R II WATER FORDING TRACTOR DJT

Configuration: D7R Series II Military Water Fording Tractor DJT00001-UP (MACHINE) POWERED BY 3176C Engine

Disassembly and Assembly D7R Series II Track-Type Tractor Power Train

Media Number -REN5626-03

Publication Date -01/09/2015

Date Updated -14/05/2018

i04905904

Steering Planetary and Brake - Disassemble

SMCS - 4132-015

Disassembly Procedure

Table 1

Required Tools			
Tool	Part Number	Description	Qty
A	138-7575	Link Bracket	3
B	1P-0520	Driver Group	1
C	5B-4274	Forcing Bolt 3/8 - 16 by 3.5 inches	3

Start By:

- A. Remove the right hand final drive, the planetary group, and the brake. Refer to Disassembly and Assembly, "Final Drive, Steering Planetary, and Brake (Right Side) - Remove".

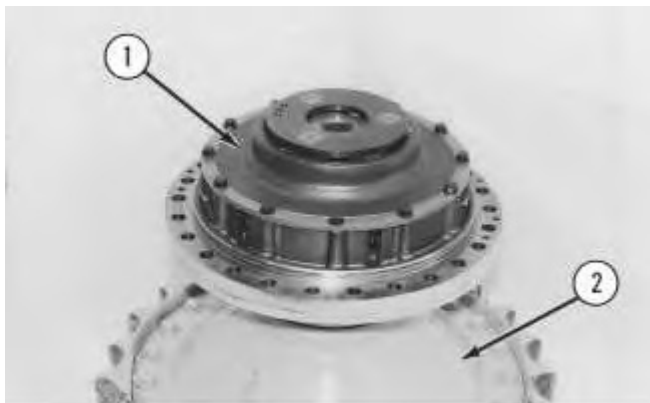

1. Position the final drive, the planetary group, and the brake, as shown.
2. Remove the bolts that hold the planetary group and brake (1) to final drive (2). The bolts are on the bottom (not shown).
3. Attach Tooling (A) and a suitable lifting device to the planetary group and brake.
4. Install Tooling (C) in the final drive hub.
5. Tighten the forcing screws evenly in order to remove the planetary group and brake (1) from final drive (2). The weight of planetary group and brake (1) is approximately 136 kg (300 lb).



Illustration 2

 **WARNING**

Personal injury can result from parts and/or covers under spring pressure.

Spring force will be released when covers are removed.

Be prepared to hold spring loaded covers as the bolts are loosened.

6. Remove bolts (3). Remove ring gear (4) from housing (5) .
-



Illustration 3

g00622110

7. Remove friction discs (6) and the brake plates from the housing.

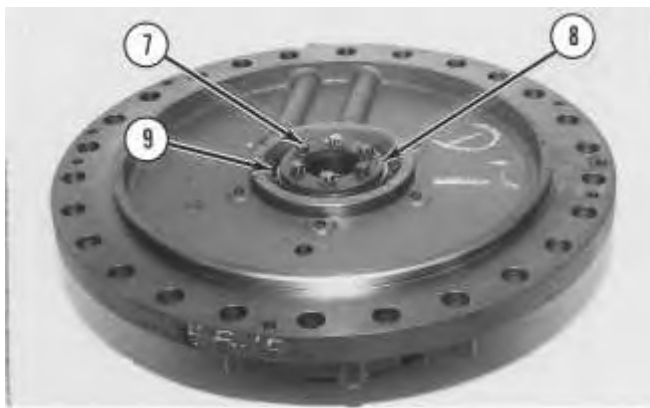

Illustration 4

g00622111

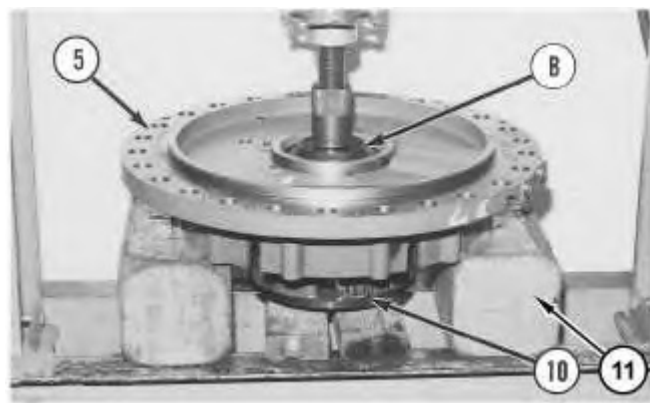

Illustration 5

g01205302

8. Remove bolts (7) and plate (8) .
9. Position the housing on suitable blocks (11) .

Note: Do not allow planetary carrier (10) to fall when the carrier is pressed from housing (5) .

Note: If a shim pack is present between the plate (8) and planetary carrier (10). Reuse the same shim pack during assembly only if reusing the same planetary carrier (10). If a new planetary carrier (10) is being used the shim pack should be discarded.

10. Use Tooling (B) and a suitable press to remove planetary carrier (10) from housing (5) .
11. Remove bearing cone (9) from the housing.

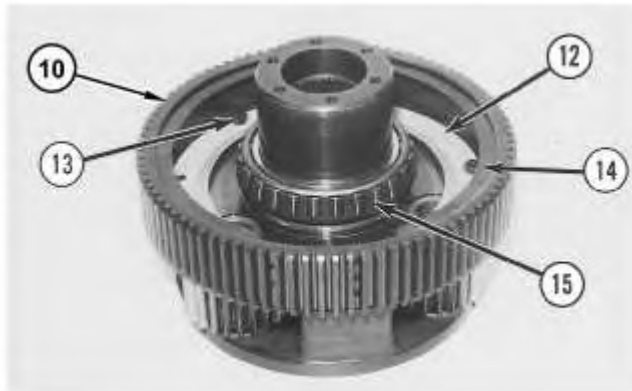

Illustration 6

g01205303

12. Remove ring (14) from planetary carrier (10). Remove bolts (13). Remove slinger (12) from the planetary carrier.

NOTICE

The component is destroyed if the component is removed.

13. If necessary, remove bearing cone (15) from planetary carrier (10) .
-



Illustration 7

g00622128

14. Use a hammer and a punch to push pin (17) in shaft (16) .

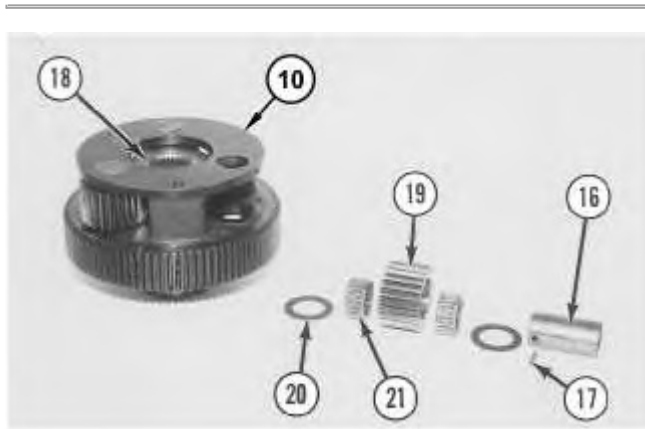

Illustration 8

g01205304

15. Remove shaft (16), planetary gear (19), discs (20), and bearings (21) from planetary carrier (10) .
16. Remove pin (17) from shaft (16) .
17. Repeat Steps 14 through 16 for the remaining planetary gears.
18. Remove sun gear (18) from planetary carrier (10) .



Illustration 9

g00622132

! WARNING

Personal injury can result from parts and/or covers under spring pressure.

Spring force will be released when covers are removed.

Be prepared to hold spring loaded covers as the bolts are loosened.

19. Remove bolts (22) and washers.
20. Remove retainer (23) from piston (24) .



Illustration 10

g00622155

21. If necessary, remove bearing cups (25) and seal ring (26) from retainer (23) .



Illustration 11

g00622156

22. Remove piston (24) and O-ring seal (27) from the housing.



Illustration 12

g00622157

23. Remove seal ring (28) from piston (24) .

Note: Inspect the O-ring seals. If necessary, replace the O-ring seals.



Illustration 13

g00819345

Thank you so much for reading.
Please click the “Buy Now!”
button below to download the
complete manual.



After you pay.

You can download the most
perfect and complete manual in
the world immediately.

Our support email:

ebooklibonline@outlook.com