



Service Repair Manual

Models

D6T TRACK-TYPE TRACTOR

Product: TRACK-TYPE TRACTOR

Model: D6T TRACK-TYPE TRACTOR WCG

Configuration: D6T TRACK-TYPE TRACTOR XL VPAT, XW VPAT, LGP VPAT Differential Steering WCG00001-UP (MACHINE) POWERED BY C9 Engine

Disassembly and Assembly D6T Track-Type Tractor Power Train

Media Number -KENR5126-07

Publication Date -01/01/2013

Date Updated -25/07/2018

i02406212

Transmission - Disassemble

SMCS - 3030-015

Disassembly Procedure

Table 1

Required Tools			
Tool	Part Number	Part Description	Qty
A	1P-2420	Transmission Repair Stand	1
B	5P-5197	Retaining Ring Pliers	1
C	138-7575	Link Bracket	3
D	5P-4758	Internal Pliers	1
E	FT-0947	Spring Compressor	2
F	138-7574	Link Bracket	2
G	3K-4897	Spring Pin	8

Start By:

- a. Separate the transmission and bevel gear. Refer to Disassembly and Assembly, "Transmission and Bevel Gears - Separate".

Note: The transmission modulating valves must be recalibrated if any of the following procedures are performed:

- The transmission modulating valve and/or the solenoid is replaced.
 - The transmission is serviced or replaced.
 - The ECM is replaced.
-

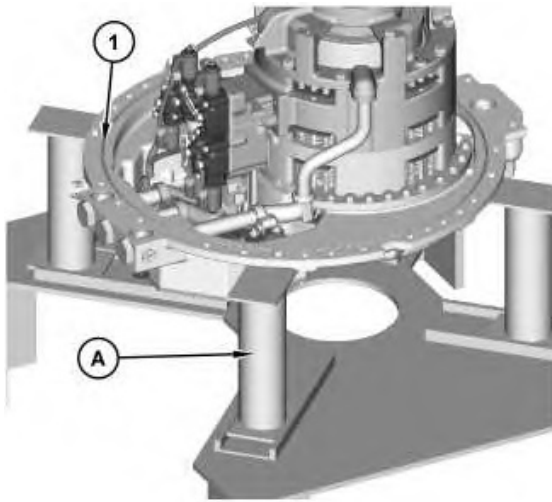

Illustration 1

g01201936

1. Position the transmission on Tooling (A). Put alignment marks on all the housings prior to disassembly.
2. Remove O-ring seal (1).

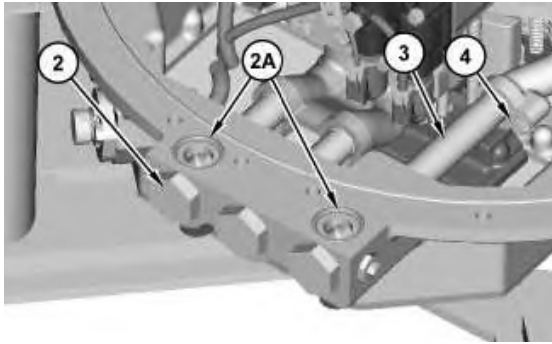

Illustration 2

g01201956

3. Remove O-ring seals (2A) and plugs (2).
 4. Remove retainers (4).
 5. Remove tubes (3).
-

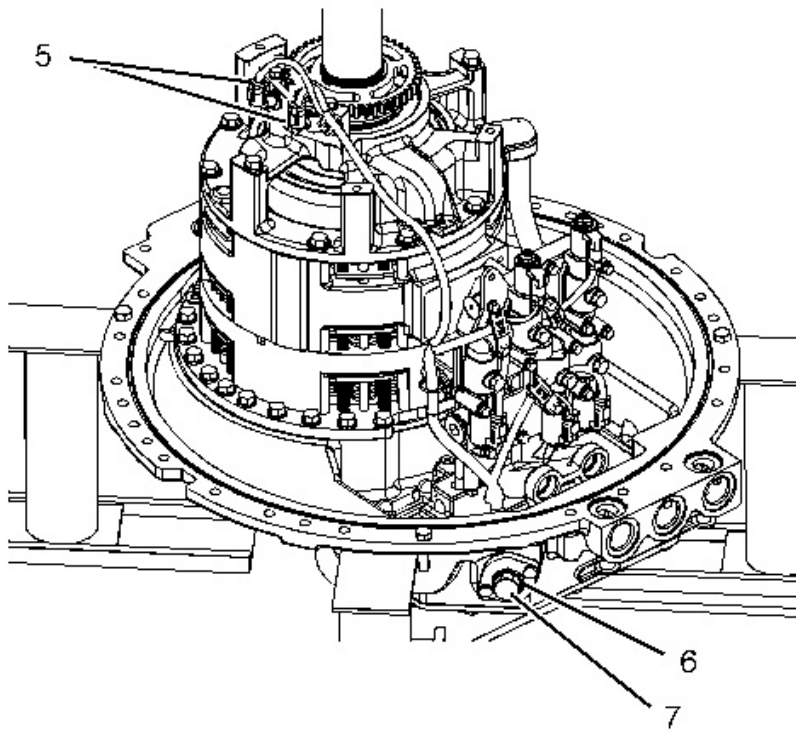

Illustration 3

g01201973

6. Remove locknut (6). Push connector (7) out of the case.
7. Disconnect harness assembly (5).

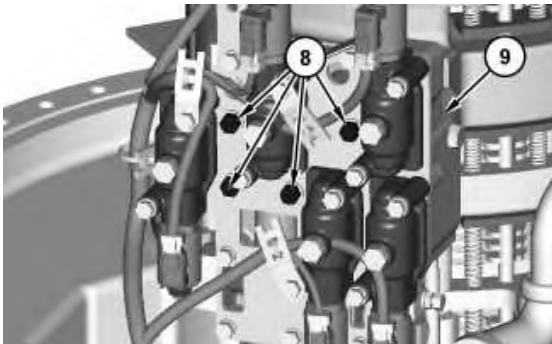
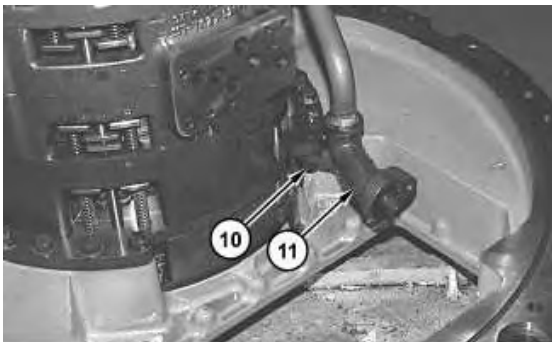

Illustration 4

g01201976

8. Remove bolts (8) and control valve (9).



9. Remove bolt (10) and tube assembly (11).
10. Remove the O-ring seal from tube assembly (11).

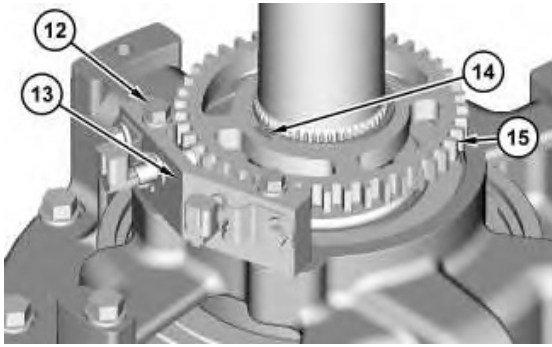

Illustration 6

11. Remove bolts (12) and bracket assembly (13).
12. Use Tooling (B) in order to remove retaining ring (14). Remove rotor (15).

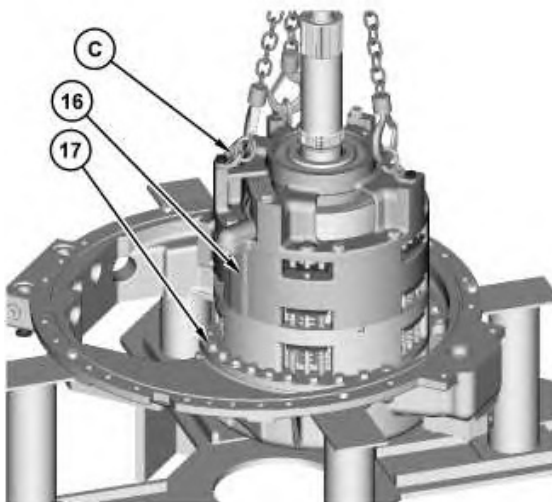

Illustration 7

13. Attach Tooling (C) and a suitable lifting device to planetary assembly (16). Remove bolts (17). Remove planetary assembly (16). The weight of planetary group (16) is approximately 341 kg (752 lb).

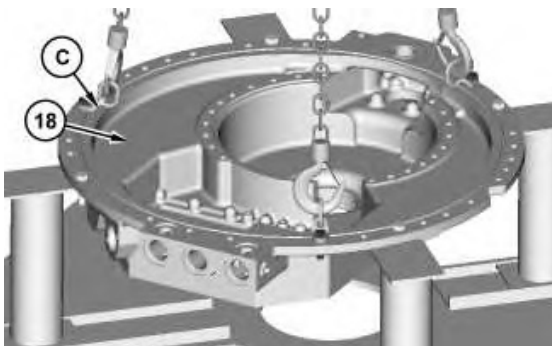

Illustration 8

Thank you so much for reading.
Please click the “Buy Now!”
button below to download the
complete manual.



After you pay.

You can download the most
perfect and complete manual in
the world immediately.

Our support email:

ebooklibonline@outlook.com