

1. Engine Crankcase Oil and Filter Element (16 & 17)*

NOTE: Check with the customer if oil has been changed and a new filter installed before doing this service.

Normal sequence of service is as follows:

Oil and filter change - after first 100 hours
- every 200 hours thereafter

If changed, record information below:

Approximate hours at change _____

If not, change as follows:

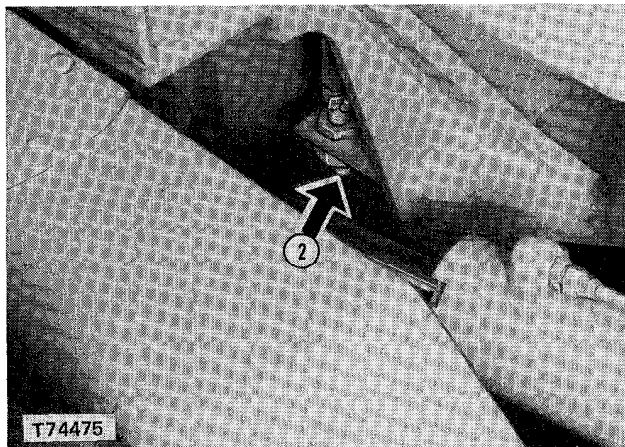

Fig. 71-Engine Crankcase Drain Plug

- 1 - Run engine to heat oil.
- 2 - Drain oil from engine crankcase.
- 3 - While crankcase is draining, install a new filter as follows:

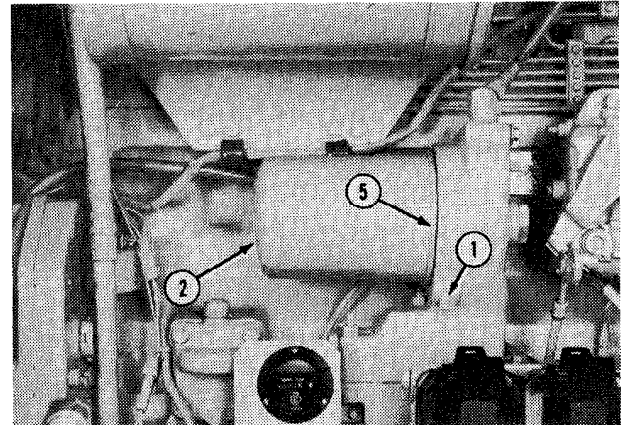

Fig. 72-Crankcase Oil Filter

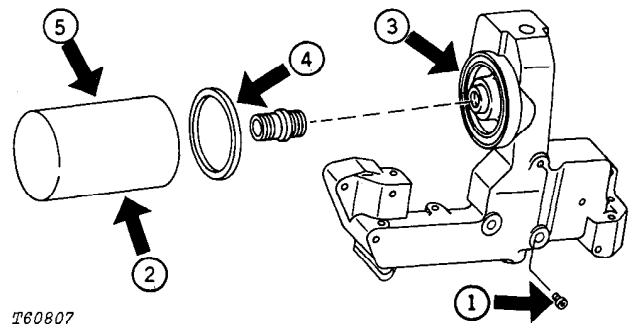
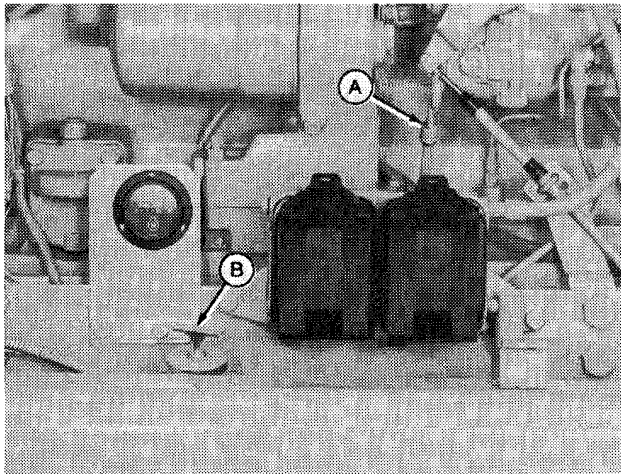

Fig. 73-Crankcase Oil Filter

- 1 - Remove pipe plug. Drain filter. Install the plug.
- 2 - Remove filter (turn counterclockwise).
- 3 - Clean mounting surface.
- 4 - Apply film of oil to packing.
- 5 - Tighten new filter until packing touches mounting surface.
- 6 - Turn an additional 1/2 to 3/4 turn.
- 7 - Install crankcase drain plug.

* Numbers in parenthesis are the same as item numbers on the periodic maintenance chart on your machine.



A—Dipstick B—Filler Cap

Fig. 74-Crankcase Dipstick and Filler Cap

- 8 - Fill crankcase with new oil specified in Group V. Capacity is 20 quarts (19 L) with filter.

IMPORTANT: Before starting the grader after a filter change, crank the engine for 20 seconds with hand throttle in stop position.

- 9 - Run engine a short time and check for leaks at filter base, filter housing drain plug, and engine crankcase drain plug. Tighten filter if required. Do not overtighten.
- 10 - Stop engine and check crankcase oil level. Oil must be at top mark on dipstick when dipstick rests on filler tube.

Crankcase oil changed	Yes	No
Oil filter element changed	Yes	No

2. Transmission-Hydraulic System Oil Level and Filters

NOTE: Before checking oil level find out if customer has changed filters (first 50 hours service).

If changed at an earlier date, record information below:

Approximate hours at change _____

If not, change as follows:

Transmission Oil Filter (21)

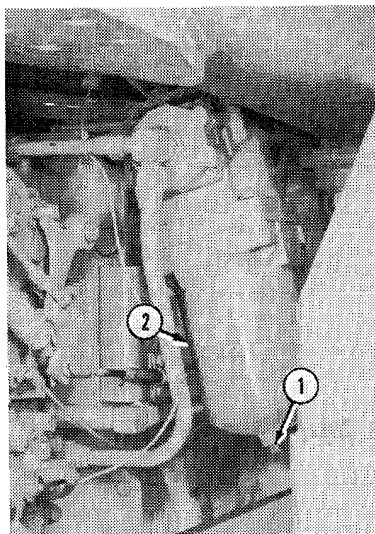
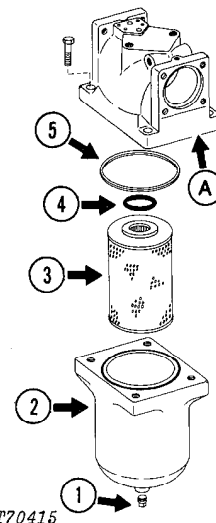

Fig. 75-Transmission Oil Filter



T70415

Fig. 76-Transmission Oil Filter

- 1 - Remove pipe plug.
- 2 - Loosen the filter housing slightly to allow oil to drain. After oil has drained, remove the housing.
- 3 - Remove filter element. Clean the housing. Install new element.

IMPORTANT: Be sure O-ring fits correctly in filter head (A) or filter may be damaged when cap screws are tightened.

- 4 - Install housing seal in the filter housing groove.
- 5 - Install housing and pipe plug.

Hydraulic Oil Filter (25)

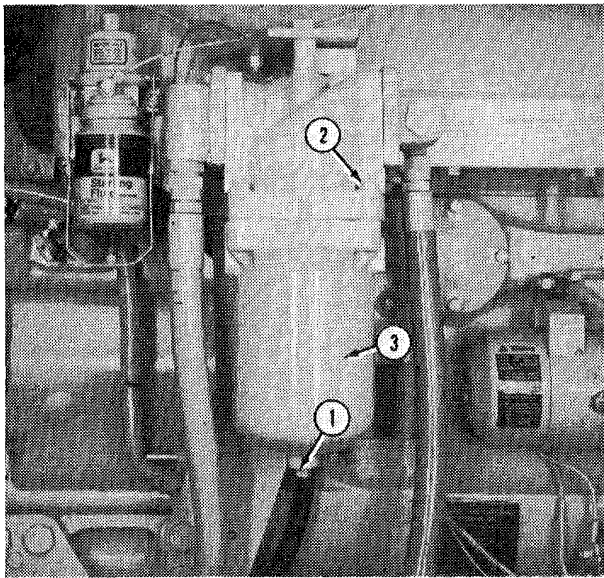

Fig. 77-Hydraulic Oil Filter

T92856

6 - Install new element and housing.

IMPORTANT: Install a John Deere filter element.

7 - Start the engine, operate hydraulic functions, and check for leaks.

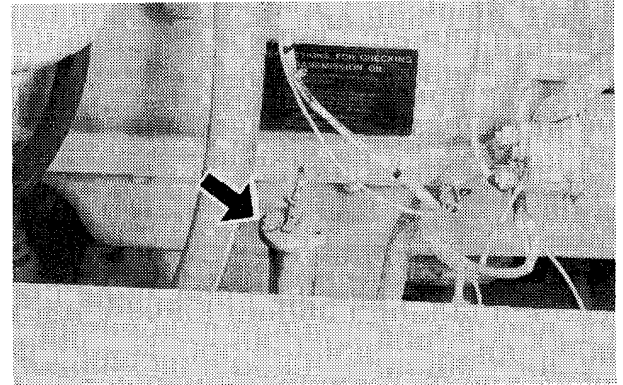

T92851

Fig. 79-Transmission Dipstick and Filler Cap

8 - Check oil level after engine has been shut off a minimum of 10 minutes. Level should be at top mark on dipstick while resting on filler tube.

9 - Add oil specified in Group V, if needed.

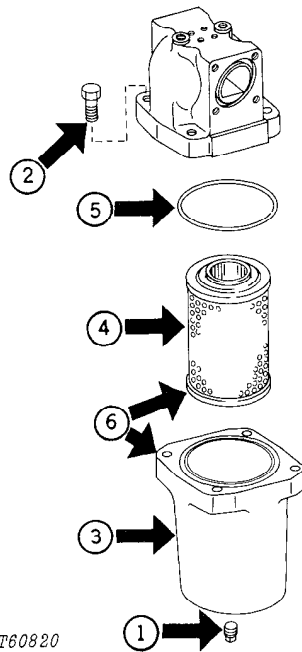

T60820

Fig. 78-Hydraulic Oil Filter

T60820

- 1 - Remove pipe plug.
- 2 - Loosen filter housing slightly.
- 3 - After oil drains, remove filter housing.
- 4 - Remove element and housing seal (5).
- 5 - Install new housing seal. Be sure it's fully seated.

Oil level checked	Yes	No
New filter elements installed	Yes	No

3. Tandem Drive Oil Level (19)

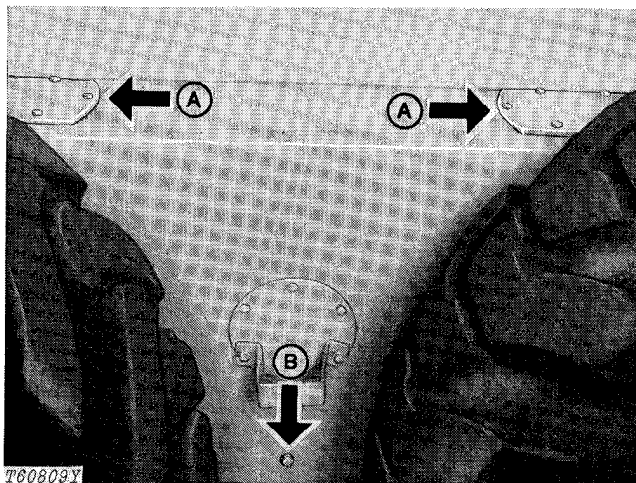

A—Inspection Plates

B—Oil Level Plug

Fig. 80-Tandem Drive Oil Level

- 1 - Park the grader on a level surface.
- 2 - Check the oil level in each tandem.
- 3 - Remove the oil level plug (B). Oil must be level with the oil level plug hole.
- 4 - If not, remove one of the inspection plates. Add oil specified in Group V.
- 5 - Reinstall the inspection plate.

Tandem drives oil level checked Yes No
 Oil added _____qts. (L)

4. Circle Drive Gearbox Oil Level (18)

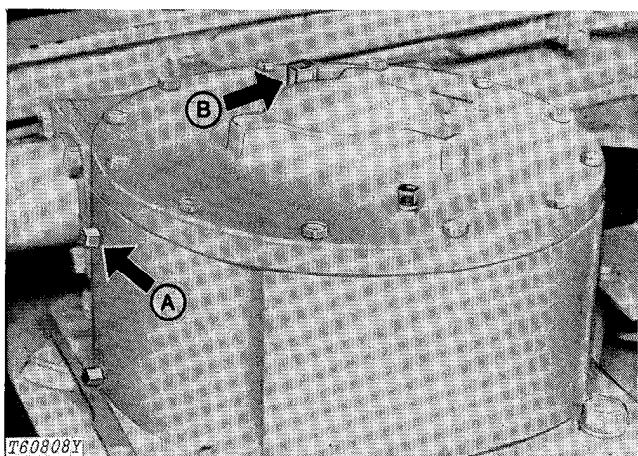

A—Oil Level Plug

B—Filler Plug

Fig. 81-Circle Drive Gearbox

- 1 - Park the grader on level ground.
- 2 - Lower the blade to the ground.
- 3 - Remove the oil level plug (A). Oil must be level with the hole.
- 4 - When needed, remove filler plug (B) and add oil specified in Group V.
- 5 - Install filler plug and oil level plug.

Circle drive gear box
 oil level checked Yes No
 Oil added _____qts. (L)

5. Pre-Cleaner (1)

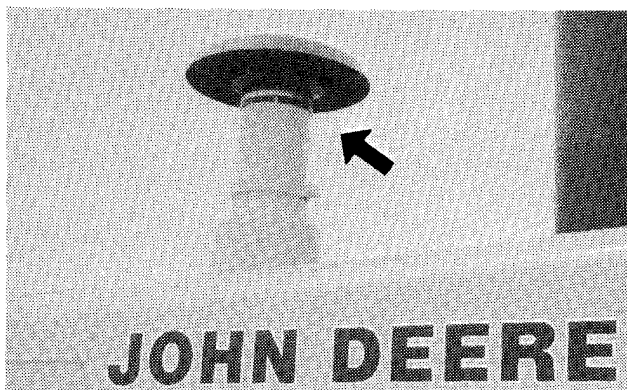

Fig. 82-Pre-Cleaner/Dust Cap

Check and clean dust cap openings.

Pre-cleaner checked and cleaned Yes No

6. Air Cleaner (3)

Check air cleaner restriction indicator on instrument panel. If indicator shows red, check and clean both primary and safety elements. Install new elements, if necessary.

Air cleaner checked Yes No
 New elements installed Yes No

7. Radiator (5)

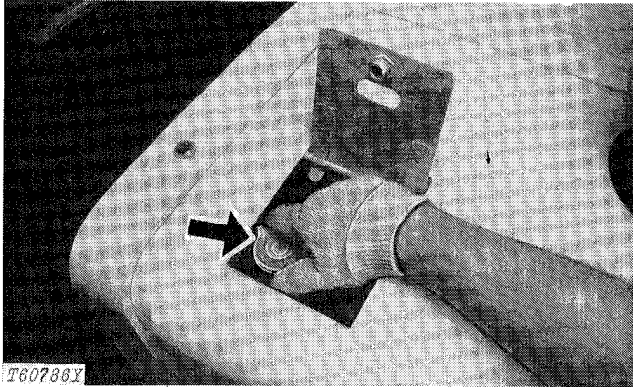

Fig. 83-Removing Radiator Cap

CAUTION: Do not remove the radiator filler cap unless you can hold your hand on the radiator tank. First, loosen the cap slowly to the stop. Then release all pressure in the cooling system before removing the cap.

Check the coolant level. Keep coolant 4 inches (102 mm) below the top of the filler neck. Use clean water for warm weather. Use a solution of 50% clean water and 50% permanent antifreeze (ethylene glycol with approved rust inhibitor) for cold weather.

IMPORTANT: Do not use methoxy propanol antifreeze (such as Dowtherm 209 antifreeze or its equivalent) in the coolant solution. It may damage the cylinder sleeves and seals.

Check the cooling system for loose connections and leaks. Remove trash from the radiator.

Coolant level checked Yes No

8. Batteries (12)

Check electrolyte level of the batteries. If distilled water is not available, use clean soft water. Do not use hard water. Remove dirt from the top of the batteries with a damp cloth. Put petroleum jelly on terminals.

IMPORTANT: Never add water to the batteries in freezing weather unless the engine will be run 2 or 3 hours.

Check battery connections.

Batteries checked Yes No

9. Tire Pressure (13)

Check the air pressure in all tires with an accurate gauge having 1 psi (0.07 bar) graduations.

When more pressure is needed, use a pressure regulating valve with a tire valve stem locking air chuck.

When adding air to the tire, stand to the front or rear of the grader.

Tire Size	Ply Rating	Type	Inflation Pressure-psi (kPa)
13.00-24	12	G-2	35 (241)
14.00-24	10	G-2	30 (207)
14.00-24	12	G-2	35 (241)
17.5 -25	12	L-2	30 (207)*

*For sloping and ditching, inflate to 45 psi (208 kPa).

NOTE: Be sure that tire inflation pressures are equal for all six tires.

NOTE: When adding a new rear tire, inflate rear tires so the rolling radius of all tires is the same.

For maintenance work on established highways, inflation pressure can be increased up to 50% if desired.

Tire pressure checked Yes No

10. Fuel Tank

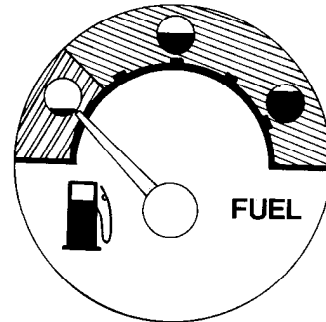

T40227N

Fig. 84-Fuel Level Gauge

T40227N

Fuel gauge shows amount of fuel in fuel tank. Add a small amount of correct fuel to tank. Check action of gauge.

Fuel gauge checked Yes No

11. Fuel Tank Sump (15)

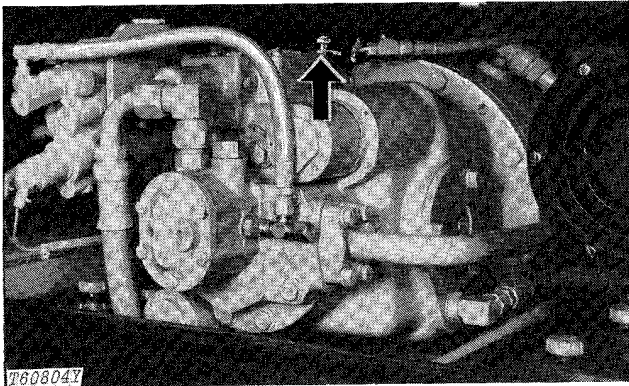
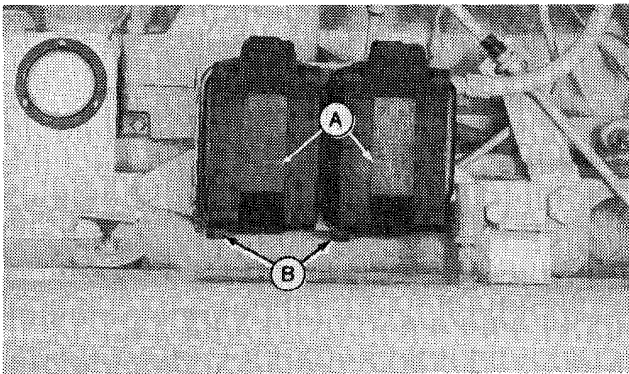

Fig. 85-Fuel Tank Drain Cock

Open fuel tank drain cock. Drain liquid for several seconds. Close drain cock.

Fuel tank sump drained Yes No

12. Fuel Filters



A—Fuel Filters

B—Drain Screws

Fig. 86-Fuel Filters

Check fuel filters for sediment. Open drain screws. Drain for several seconds. Tighten drain screws. Open bleed screw until fuel flows free from bubbles. Tighten bleed screw.

Sediment present in filters Yes No
 Air removed from filters Yes No

13. Lubrication

Check each lubrication point shown in the following pages. Lubricate with several strokes of John Deere Multi-Purpose Grease or equivalent, if necessary.

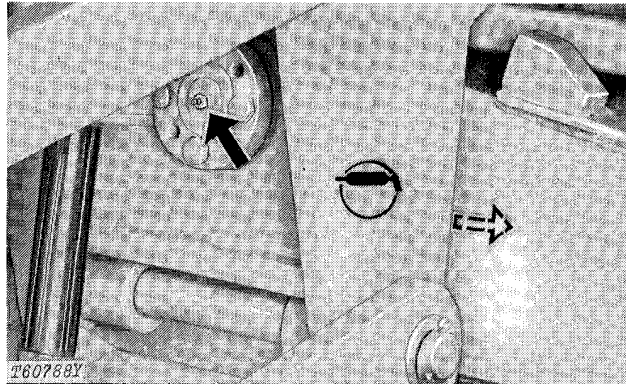

Fig. 87-Front Axle (2 points)

Lubrication required Yes No

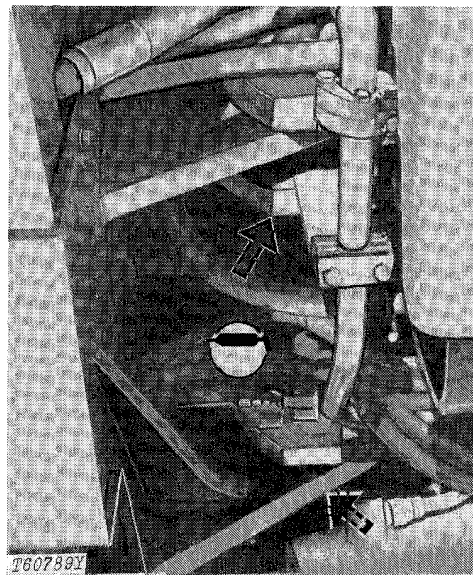

Fig. 88-Frame Pivots (2 points)

Lubrication required Yes No



Suggest:

If the above button click is invalid.

Please download this document

first, and then click the above link

to download the complete manual.

Thank you so much for reading