



70 Skid-Steer Loader



JOHN DEERE

TECHNICAL MANUAL

70
Skid-Steer Loader

TM1072 (01JAN74) English

John Deere
Lawn & Grounds Care Division
TM1072 (01JAN74)

LITHO IN U.S.A.
ENGLISH



70 SKID-STEER LOADER

Technical Manual
TM-1072 (Jan-74)

CONTENTS

- SECTION 10 - GENERAL
 - Group 5 - Specifications
 - Group 10 - Predelivery, Delivery, and After Sales Service
 - Group 15 - Tune Up and Adjustment
 - Group 20 - Lubrication
- SECTION 20 - ENGINE
 - Group 5 - Diagnosing Engine Malfunctions
 - Group 10 - Basic Engine
 - Group 15 - Repair, Assembly, and Adjustments of Engine
 - Group 20 - Specifications and Special Tools
- SECTION 30 - FUEL SYSTEM
 - Group 5 - Diagnosing Fuel System Malfunctions
 - Group 10 - Carburetor
 - Group 15 - Fuel Filter and Fuel Pump
 - Group 20 - Specifications and Special Tools
- SECTION 40 - ELECTRICAL SYSTEM
 - Group 5 - Diagnosing Electrical System
 - Group 10 - Battery and Wiring Diagrams
 - Group 15 - Charging System
 - Group 20 - Ignition System
 - Group 25 - Starting Motor
 - Group 30 - Specifications and Special Tools
- SECTION 50 - POWER TRAIN
 - Group 5 - Diagnosing Hydrostatic Drive System
 - Group 10 - Operation of Hydrostatic Pumps
 - Group 15 - Hydrostatic Pumps
 - Group 20 - Hydrostatic Motor
 - Group 25 - Axle Assemblies
 - Group 30 - Center Reduction Gear
 - Group 35 - Specifications and Special Tools
- SECTION 60 - STEERING AND BRAKES
 - Group 5 - Steering
 - Group 10 - Brakes
 - Group 15 - Specifications and Special Tools
- SECTION 70 - HYDRAULIC SYSTEM
 - Group 5 - Diagnosing Hydraulic System
 - Group 10 - Hydraulic Pump
 - Group 15 - Hydraulic Control Valve
 - Group 20 - Hydraulic Cylinders
 - Group 25 - Hydraulic Oil Filter
 - Group 30 - Specifications and Special Tools

FOR YOUR CONVENIENCE

Vertical lines appear in the margins of many of the pages. These lines identify new material and revised information that affects specifications, procedures, and other important instructions.

"All information, illustrations and specifications contained in this technical manual are based on the latest information available at the time of publication. The right is reserved to make changes at any time without notice."

Litho in U.S.A.

*Copyright© 1974
DEERE & COMPANY
Moline, Illinois
All rights reserved*

INTRODUCTION

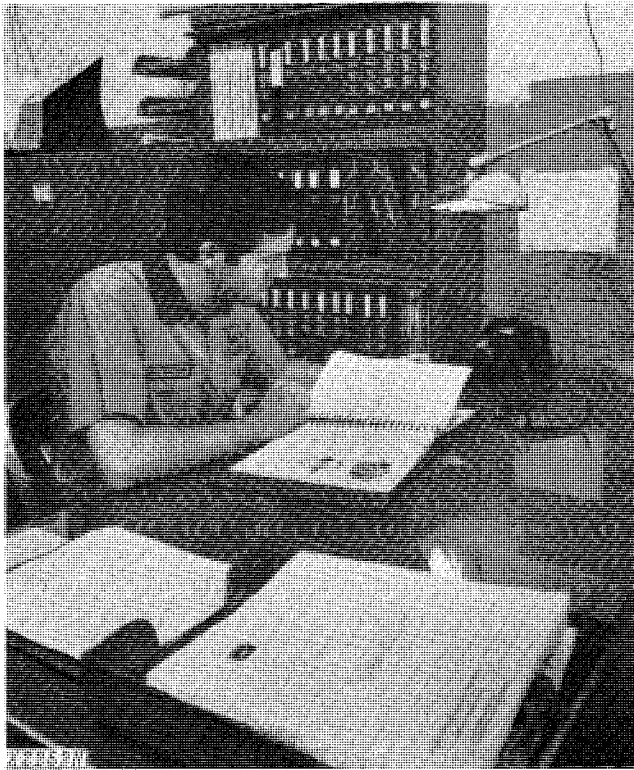

Use FOS Manuals for Reference

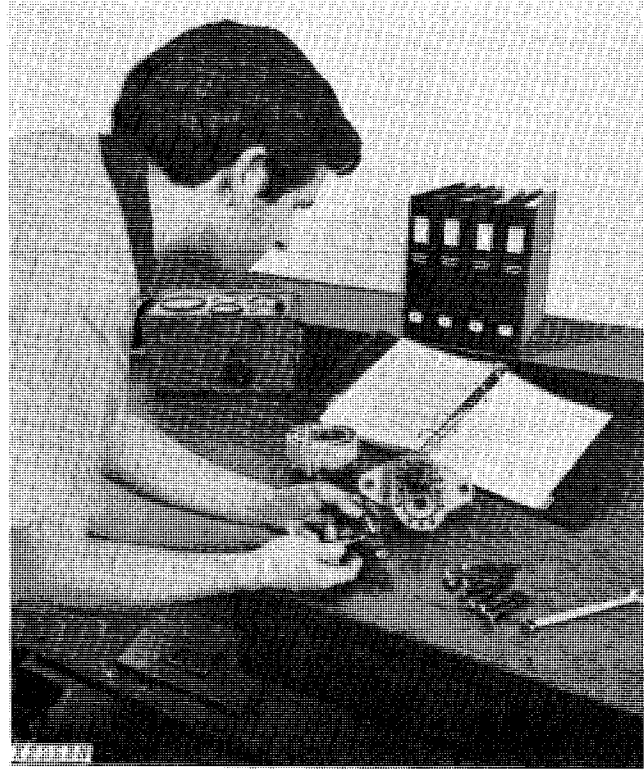

Use Technical Manuals for Actual Service

This technical manual is part of a twin concept of service:

- **FOS Manuals—**for reference
- **Technical Manuals—**for actual service

The two kinds of manuals work as a team to give you both the general background and technical details of shop service.

Fundamentals of Service (FOS) Manuals cover *basic* theory of operation, *fundamentals* of trouble shooting, *general* maintenance, and *basic* types of failures and their causes. FOS Manuals are for training new men and for reference by experienced men.

Technical Manuals are concise service guides for a *specific* machine. Technical Manuals are on-the-job guides containing only the vital information needed by a journeyman mechanic.



When a serviceman should refer to a FOS Manual for more information, a FOS symbol like the one at the left is used in the TM to identify the reference.

Some features of this technical manual:

- *Table of contents at front of manual*
- *Exploded views showing parts relationship*
- *Photos showing service techniques*
- *Specifications grouped for easy reference*

This technical manual was planned and written for you—a journeyman mechanic. Keep it in a permanent binder in the shop where it is handy. Refer to it whenever in doubt about correct service procedures or specifications.

Using the technical manual as a guide will reduce error and costly delay. It will also assure you the best in finished service work.



This safety alert symbol identifies important safety messages in this manual. When you see this symbol, be alert to the possibility of personal injury and carefully read the message that follows.

SAFETY AND YOU



T27999N

INTRODUCTION

 This safety alert symbol identifies important safety messages in this manual and on the skid-steer loader. When you see this symbol, be alert to the possibility of bodily injury and carefully read the message that follows.

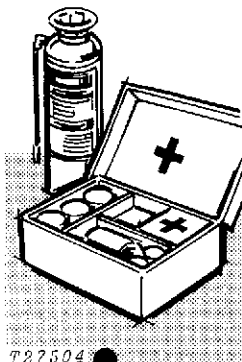

T27504

Be prepared if an accident or fire should occur. Know where the first aid kit and the fire extinguishers are located—know how to use them.

BOOM LOCKS CAUTION

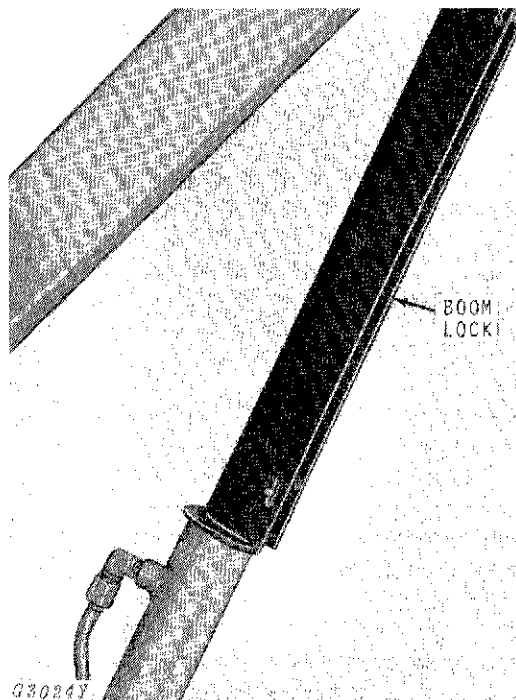

Install the boom locks on the lift cylinders as follows whenever work or repair is being done on the loader with the boom raised:

1. Start the engine and raise the boom to its greatest height. Shut off the engine.
2. Lay the boom locks on the cylinder rods and install the drilled pins and spring pins.
3. Install boom blocks on other cylinder rods in the same manner.
4. Lower the boom until it contacts the boom locks.

IMPORTANT: After servicing the loader, raise the boom and remove the boom locks.

AVOID FIRE HAZARDS

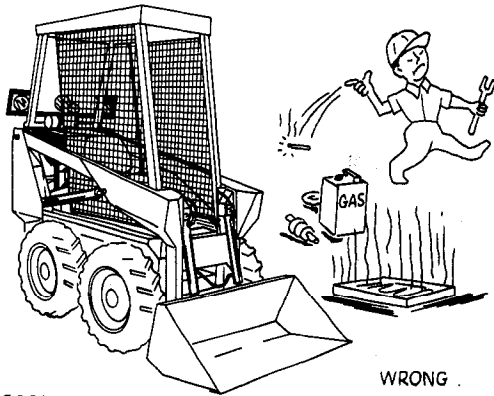

G5571N

Don't smoke while refueling or handling highly flammable material.

Engine should be shut off when refueling.

Use care in refueling if the engine is hot.

Don't use open pans of gasoline or diesel fuel for cleaning parts. Good commercial, nonflammable solvents are preferred.

Provide adequate ventilation when charging batteries.

Don't check battery charge by placing metal objects across the posts.

Don't allow sparks or open flame near batteries.

Don't smoke near battery.

Never check fuel, battery electrolyte, or coolant levels with an open flame.

Never use an open flame to look for leaks anywhere on the equipment.

Never use an open flame as a light anywhere on or around the equipment.

When preparing engine for storage, remember that internal corrosion inhibitor is volatile and therefore dangerous. Seal and tape openings after adding the inhibitor. Keep container tightly closed when not in use.

CLEANING THE LOADER

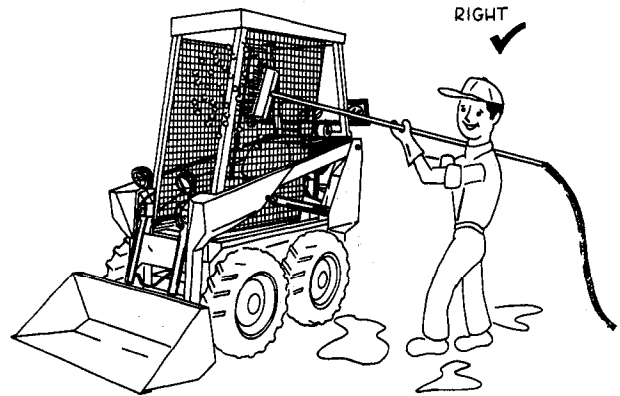

G5572N

Always stop the engine before cleaning the loader.

Keep the operator's platform clean. Do not use it as a storage area.

Keep the engine closure screens free of foreign matter. Avoid a possible fire hazard.

Keep all equipment free of dirt and oil. In freezing weather, beware of snow and ice on operator's platform.

SERVICE AREA

Keep the service area clean and dry. Wet or oily floors are slippery. Wet spots can be dangerous when working with electrical equipment.

Make sure the service area is adequately vented.

Periodically check the shop exhaust system for leakage. Engine exhaust gas is dangerous.

Be sure all electrical outlets and tools are properly grounded.

Use adequate light for the job at hand.

FLUIDS UNDER PRESSURE

Escaping fluid under pressure can have sufficient force to penetrate the skin, causing serious bodily injury. Before disconnecting lines, be sure to relieve all pressure. Before applying pressure to the system, be sure all connections are tight and that lines, pipes and hoses are not damaged. Fluid escaping from a very small hole can be almost invisible. Use a piece of cardboard or wood, rather than hands, to search for suspected leaks.

If injured by escaping fluid, see a doctor at once. Serious infection or reaction can develop if proper medical treatment is not administered immediately.

Don't forget the hydraulic system may be pressurized! To relieve pressure, follow the technical manual.

When checking hydraulic pressure, be sure to use the correct test gauge for the pressure in the particular system.

PERSONAL SAFETY



Always avoid loose clothing—flopping cuffs, dangling neckties and scarves—that can catch in moving parts and put you out of work.

Always wear your safety glasses while on the job.

Keep transmission and brake control units properly adjusted at all times. Before making adjustments, stop engine.

Before removing any housing covers, stop engine. Take all objects from your pockets which could fall into the opened housings. Don't let adjusting wrenches fall into opened housings.

Don't attempt to check chain belt tension while the engine is running.

Don't adjust the fuel system while the machine is in motion.

Before repairing the electrical system, or performing a major overhaul, make sure the batteries are disconnected.

Avoid working on equipment with the engine running. If it is necessary to make checks with the engine running, ALWAYS USE TWO MEN—one, the operator, at the controls, the other checking where the operator can see him. Also, put the transmission in neutral, set the brake, and apply any safety locks provided. KEEP HANDS AWAY FROM MOVING PARTS.

Use extreme caution in removing drain plugs, grease fittings, or hydraulic pressure caps.

Section 10 GENERAL

CONTENTS OF THIS SECTION

	Page		Page
GROUP 5 - SPECIFICATIONS		GROUP 15 - TUNE-UP AND ADJUSTMENT	
Machine Specifications	5-2	Loader Tune-Up Chart	15-1
GROUP 10 - PREDELIVERY, DELIVERY, AND AFTER SALES SERVICES		GROUP 20 - LUBRICATION	
Predelivery Service	10-1	Lubrication Chart	20-1
Delivery Service	10-1	Engine Lubricating Oil	20-1
After-Sales Service	10-2	Hydraulic and Hydrostatic Oil	20-2

Group 5 SPECIFICATIONS

LOADER DESIGN

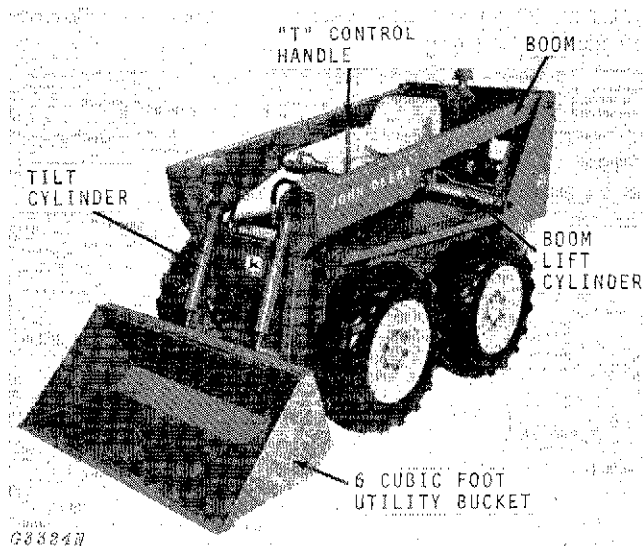

Fig. 1-70 Skid-Steer Loader

The John Deere 70 Skid Steer Loader is a 700-pound capacity, self-propelled, four-wheel drive machine used for miscellaneous material handling operations. It has the ability to maneuver in small, tight areas.

All references in this manual to "front", "rear", "left-hand", and "right-hand" are in relation to the position of operator seated in the operator's station.

SERIAL NUMBER

The serial number plate is located on the right side—inside the frame under the boom pivot.

MACHINE SPECIFICATIONS

ENGINE

Make Onan
 Flywheel horsepower at 3200 rpm..... 23.5 hp
 Maximum torque (ft-lbs) at 2400 rpm..... 40 ft-lbs
 Number of cylinders 2
 Bore and stroke 3.56 x 3 in.
 Piston displacement..... 60.0 cu. in.
 Compression ratio 7.0 to 1
 Intake valve clearance..... .003 in.
 Exhaust valve clearance010 in.
 Slow idle (serial no. 01072 and below) .. 500 rpm
 Fast idle (serial no. 01072 and below) . 2400 rpm
 Slow idle (serial no. 01073 and up)..... 900 rpm
 Fast idle (serial no. 01073 and up)..... 3200 rpm
 Starting..... Electric
 Fuel..... Gasoline (regular grade)
 Governor..... Cam gear driven, mechanical fly ball

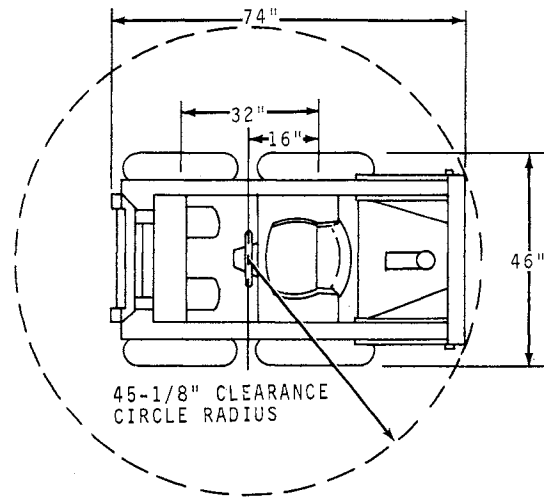

G3055N

Fig. 2-Turning Radius

ELECTRICAL SYSTEM

Battery voltage 12 volts
 Battery terminal grounded Negative
 Alternator regulation Regulator-rectifier
 Ignition system type Battery-breaker box
 Breaker point gap020 in.
 Spark plugs
 Size 14 MM
 Gap025 in.

TRANSMISSION

Make Cessna
 Type Hydrostatic piston pumps with two rotor-type charge pumps

TRAVEL SPEEDS

Forward or reverse 0 to 5 mph

HYDRAULIC SYSTEM

Type Open center, constant volume system to operate loader boom and bucket
 Pump Transmission-mounted, gear type

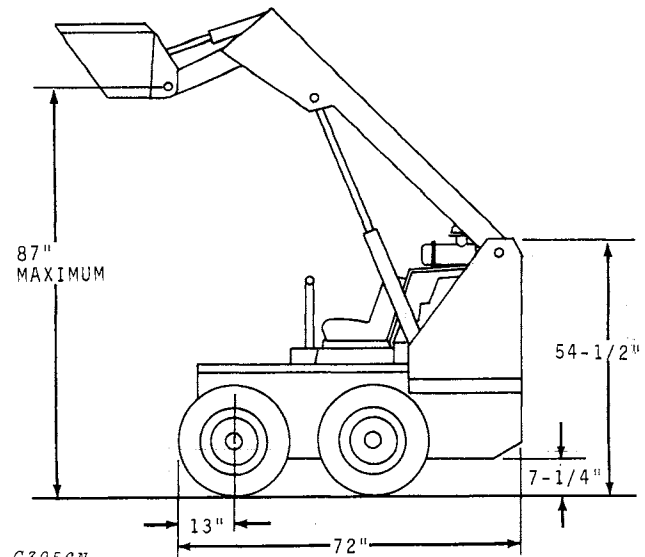

G3056N

Fig. 3-Loader Dimensions

CAPACITIES (U.S. STANDARD MEASURES)

Fuel tank 11 gal.
 Engine crankcase (with filter) 4 qts.
 Hydraulic and hydrostatic system Approx. 15 gal.
 Oil filter 1/2 qt.; spin-on

TIRES

Type 4-ply-rated, tubeless
 Size 27-8.50-15

Group 10

PREDELIVERY, DELIVERY AND AFTER-SALES SERVICES

PREDELIVERY SERVICE

Service	Specification	Reference
Check battery for electrolyte level and specific gravity	1.260 specific gravity when fully charged	See operator's manual.
Check battery terminal connections		See operator's manual.
Adjust pressure of tires	30 to 32 psi	See operator's manual.
Check wheel nuts for tightness	90 ft-lbs torque
Check crankcase oil level	Fill to top mark on oil level indicator	See operator's manual.
Lubricate grease fittings		See operator's manual.
Check hydraulic reservoir level	Fill to top mark on bayonet gauge	See operator's manual.

DELIVERY SERVICE

A thorough discussion of the operation and service of a new loader at the time of delivery helps to assure complete customer satisfaction.

Complaints may arise if the owner is not shown how to operate and service his new loader correctly. Devote enough time, at your customer's convenience, to introduce him to his new loader.

The following procedure is recommended before the service man delivers the loader to the owner.

Using the operator's manual as a guide be sure the owner thoroughly understands the following points:

1. Operation and use of controls.
2. Operation of the engine.
3. Operation and functions of the hydraulic and hydrostatic systems.
4. Importance of lubrication and periodic services.
5. Importance of safety.
6. Terms and conditions of warranty.

After explaining and demonstrating the above points, have the owner sign the delivery receipt and give him his operator's manual.

AFTER-SALES SERVICE

The purpose of this inspection is to ensure that the customer is receiving satisfactory performance from his loader.

During the inspection service, the dealer has the opportunity of promoting the sale of additional new equipment and accessories.

At the same time, the inspection should reveal whether or not the machine is being operated, lubricated, and serviced properly.

The following inspection program is recommended within the first 100 hours of operation.

Service	Specification	Reference
Check battery specific gravity and electrolyte level	1.260 specific gravity when fully charged	See operator's manual.
Check engine crankcase oil level	Fill to top mark on oil level indicator	See operator's manual.
Check oil level in hydraulic reservoir	Top mark on gauge	See operator's manual.
Check wheel nuts and studs	90 ft-lbs torque
Tighten all accessible cap screws and nuts
Check air cleaner	See operator's manual.
Fill fuel tank and start engine	11 U.S. gallons	See operator's manual.
Check operation of starter and gauges	See operator's manual.
Check operation of hydrostatic control	See operator's manual.
Check hydraulic system operation	See operator's manual.
Check hydrostatic system for leaks	See operator's manual.
Check seat operation	See operator's manual.



Suggest:

If the above button click is invalid.

Please download this document

first, and then click the above link

to download the complete manual.

Thank you so much for reading

Group 15

TUNE-UP AND ADJUSTMENT

Perform all the tune-up steps to put the loader in top operating condition if major assembly and repair is not required.

Operation	Specification	Reference
Air intake system		
Check air filter		See operator's manual
Backflush engine		See operator's manual
Ignition system		
Clean, test, or replace spark plugs025-inch gap	See page 40-20-2
Check, adjust, or replace points020-inch gap	See page 40-20-1
Check breaker box and wiring		See pages 40-20-1 and 40-10-2
Time breaker box to engine	22° BTC (Serial No. 01072 and below)	See page 40-20-2
	25° BTC (Serial No. 01073 and up)	See page 40-20-4
Battery		
Check electrolyte level	1.260 specific gravity when fully charged	See operator's manual
Clean cables, terminals, and holder		See page 40-10-1
Tighten cable clamps		See page 40-10-1
Fuel system		
Check fuel tank and lines for leakage		
Check fuel filter		See operator's manual
Check carburetor		See page 30-10-1
Tires and wheels		
Check tire inflation	30 to 32 psi	See operator's manual
Check for proper torque value on wheel lug bolt nuts	90 ft-lbs torque	See operator's manual
Electrical system		
Check ammeter gauge		
Check fuses		See operator's manual
Check alternator-regulator (Flywheel type)		See page 40-15-1
Hydraulic system		
Check hydraulic oil filter		See page 70-25-1
Check hydraulic oil level	15 U.S. gallons	See operator's manual
Check control valve for leaks		Section 70, Group 15
Check system for leaks		Section 70, Groups 10, 15, and 20