

**John Deere
JD450B
Crawler Tractor**

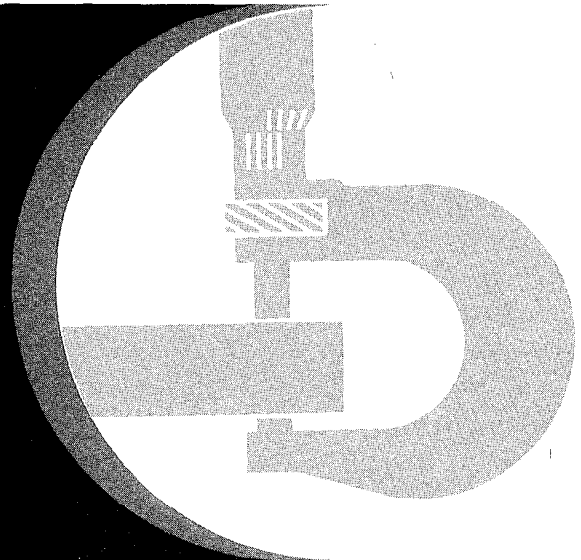

TECHNICAL MANUAL

**John Deere Dubuque Works
TM-1033 (May-87)**

Litho in U.S.A.

JD450-B CRAWLER TRACTORS AND CRAWLER LOADERS

Technical Manual
TM-1033 (May-87)

CONTENTS

SECTION 10 - GENERAL

- Group 5 - Specifications
- Group 10 - Predelivery, Delivery, and After-Sales Services
- Group 15 - Tune-up and Adjustment
- Group 20 - Lubrication
- Group 25 - Separation

SECTION 20 - ENGINE

- Group 5 - Diagnosis
- Group 10 - Basic Engine
- Group 15 - Engine Lubrication System
- Group 20 - Speed Control Linkage
- Group 25 - Engine Cooling System
- Group 30 - Specifications and Special Tools

SECTION 30 - FUEL SYSTEM

- Group 5 - Diagnosis
- Group 10 - Fuel Tank, Transfer Pump and Filters
- Group 15 - Air Intake System
- Group 20 - Fuel Injection Pump

SECTION 40 - ELECTRICAL SYSTEM

- Group 5 - Description and Electrical Schematic
- Group 10 - Charging System
- Group 15 - Starting Motor
- Group 20 - Gauges and Switches

SECTION 50 - POWER TRAIN

- Group 5 - Diagnosis
- Group 10 - Clutch Assembly
- Group 15 - H-L-R Transmission
- Group 20 - Power Take-off and Winch Drive
- Group 25 - Specifications and Special Tools

SECTION 60 - STEERING AND BRAKES

- Group 5 - General Information, Testing and Diagnosis
- Group 10 - Power Steering Pump
- Group 15 - Power Steering Cylinders and Reservoir
- Group 20 - Final Drive Assembly
- Group 25 - Steering and Brake Assembly

SECTION 70 - HYDRAULIC SYSTEM

- Group 5 - General Information, Testing, and Diagnosis
- Group 10 - Hydraulic Components
- Group 15 - Hydraulic Pump
- Group 20 - Loader Control Valve
- Group 25 - Dozer Control Valve
- Group 30 - Backhoe Control Valve
- Group 35 - Hydraulic Cylinders
- Group 40 - Backhoe Swing Cylinder

SECTION 80 - MISCELLANEOUS COMPONENTS

- Group 5 - Tracks
- Group 10 - Track Carrier Assembly
- Group 15 - Winch System
- Group 20 - Dozer Frames and Blades
- Group 25 - Loader Frame, Boom, and Bucket
- Group 30 - Drott 4-in-1 Bucket
- Group 35 - Lumber Fork and Pulpwood Loader
- Group 40 - Backhoe Boom and Bucket

INDEX

Copyright® 1987

Section 10 GENERAL

CONTENTS OF THIS SECTION

	Page		Page
GROUP 5 - SPECIFICATIONS	5-1	Transmission Hydraulic Oils	20-2
GROUP 10 - PREDELIVERY, DELIVERY, AND AFTER-SALES SERVICES		Greases	20-2
Predelivery Service	10-1	Storing Lubricants	20-2
Delivery Service	10-3	GROUP 25 - SEPARATION	
After-Sales Service	10-3	Removal and Installation	
GROUP 15 - TUNE-UP AND ADJUSTMENT		Engine	25-1
Preliminary Engine Testing	15-1	Clutch Housing	25-2
Engine Tune-Up	15-1	Final Drives	25-3
Final Engine Test	15-3	Steering Clutches	25-4
Crawler Adjustments	15-3	Transmission	25-7
GROUP 20 - LUBRICATION		Loader	25-8
Lubrication Chart (capacities and lubricants)	20-1	9250, 9300 Backhoe	25-9
Engine Lubricating Oils	20-2	Torque Values	25-10
		Special Tools	25-11

Group 5 SPECIFICATIONS

Engine

Type..... 4-cylinder in-line, valve-in-head,
 4-stroke cycle diesel

Flywheel horsepower
 (observed) at 2500 rpm 65
 Drawbar horsepower
 (observed) 48.6
 Torque (ft-lbs) max. at 1300
 rpm (observed)
 (nominal) 164.5
 Bore and stroke, inches 4.02 x 4.33
 Displacement, cubic
 inches 219
 Compression ratio 16.2:1
 Firing order 1,3,4,2

Governed speed range (rpm) 800 - 2650
 Engine disconnect clutch 11-inch, single disk,
 foot-operated

Electrical System

Battery voltage
 (nominal) 12 volts
 Ground battery terminal Negative

Hydraulic System

Type.... Open-center; includes power steering,
 brakes, loader, dozer, ripper, backhoe,
 and rotoboom.

Transmission

Type Manual selection, H-L-R with eight forward speeds and four reverse

Travel speeds, mph (no slip, 2500 engine rpm):

Range	High	Low	Reverse
1st	1.8	1.3	1.7
2nd	2.8	2.0	2.7
3rd	4.3	3.0	4.1
4th	6.7	4.7	6.4

Steering-Brakes

Type..... Multiple-disk clutches and contracting band with integral reservoir (early models), hydraulic pump and cylinders.

Power Take-Off

Type.... Transmission-driven, rear, 1000 rpm at 1900 rpm engine speed.

Track and Track Frame

Five rollers non-oscillating, one carrier roller each side. Hydraulic track adjusters. 36 track shoes per side (Dozer). 37 track shoes per side (Loader).

Track Shoes

Type	Size (Inches)
Grouser	14, 16, 18
Rubber	13
Notched Open-Center Grouser	16
Triple Semi-Grouser	13, 14, 16
Open Center Grouser	14, 16, 18

Capacities (U.S. Standard Measures)

Fuel tank	31 gal.
Cooling system	16 qts.
Engine crankcase (including filter)	9 qts.
Transmission case	32 qts.
Final drives (each)	6.5 qts.
Crawler loader hydraulic system	13 gal.
(with fork and single clamp)	15 gal.
(with fork and dual clamps)	16 gal.
Crawler tractor hydraulic system	8 gal.
Winch housing reservoir	9 qts.
Winch drum:	
(with 1/2-inch cable)	195 ft.
(with 5/8-inch cable)	125 ft.
(with 3/4-inch cable)	100 ft.

Weight Distribution

	Loader	Bulldozers		
		6405	6410	6415
SAE Operating Weight (lbs.)*	16,700	14,250	14,250	14,500
Ground Contact (Sq. In.)	2,128	2,328	2,328	2,328
Ground Pressure (psi)	7.8	6.1	6.1	6.2
Track on Ground (inches)	76	72.75	72.75	72.75

* 1973 Representative Tractor
Includes fully serviced tractor, 175 lb. operator, and R.O.P.S.

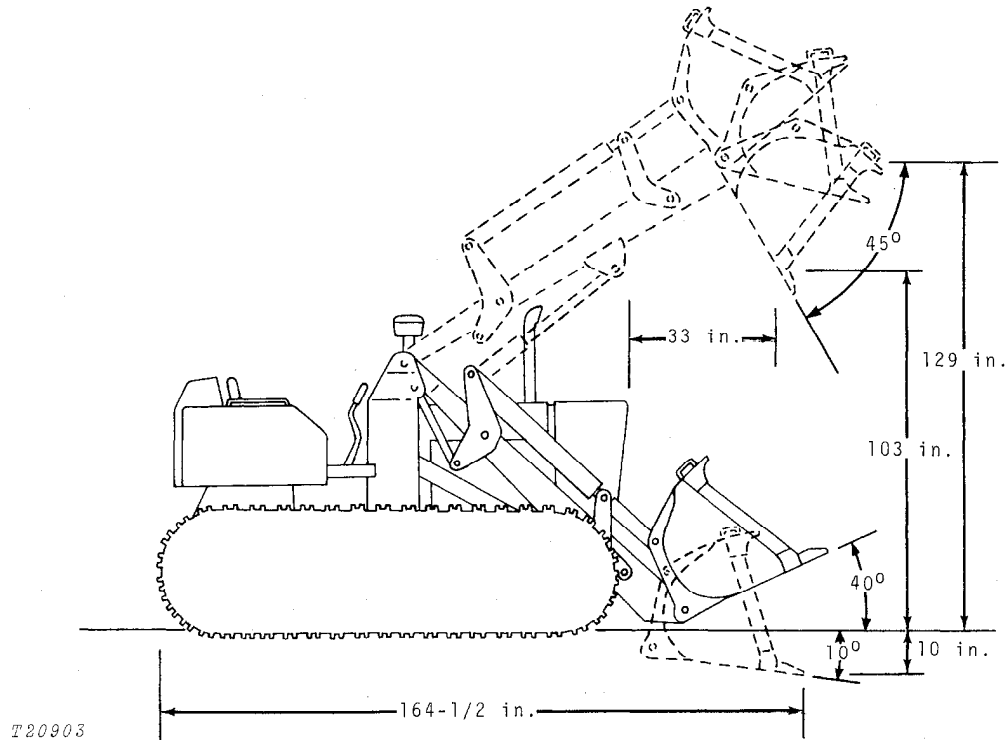

JD450-B Operating Dimensions

DIMENSIONS (Crawler Tractor)

Height to top of hood	57 in.
Over-all height (with exhaust stack)	89 in.
Over-all width, minimum (with 14 in. shoes)	65-3/4 in.
Over-all length	109-1/4 in.
Ground clearance (at rear crossbar)	14-1/4 in.
Shipping weight (approx.)	11,600 lbs.

DIMENSIONS (Crawler Loader)

Over-all length	164-1/4 in.
Over-all height (with exhaust stack)	89 in.
Over-all width (minimum) (with 14 in. shoes)	72-1/4 in.

Ground clearance (at rear crossbar)	14-1/4 in.
Dumping reach (full height) (bucket at 45° angle)	33 in.
Dumping clearance (full height) (bucket at 45° angle)	103 in.
Maximum lift (bucket at full height)	129 in.
Digging depth below ground (10 degrees)	4-1/2 in.
Bucket width (1-1/4 yd. bucket)	72-1/4 in.
Maximum dump angle	
Full height	50° from horizontal
Ground level	70° from horizontal
Bucket roll-back (ground level)	40°
Operating weight, approximate	16,390 lbs.
Hydraulic lift capacity (full height)	9,000 lbs.
Breakout force	14,360 lbs.

Group 10

PREDELIVERY, DELIVERY, AND AFTER-SALES SERVICES

PREDELIVERY SERVICE

Because of the shipping factors involved, plus extra finishing touches that are necessary to promote customer satisfaction, proper predelivery service is of prime importance to the dealer.

A tag pointing out the factory-recommended procedure for predelivery service is attached to each new crawler before it leaves the factory.

After completing the factory-recommended dealer checks and services listed on the predelivery tag, remove the tag from the crawler and file it with the job shop order. The tag will then serve as a basis for certifying that the crawler has received the proper predelivery service when that portion of the customer's John Deere Delivery Receipt is completed.

TEMPORARY CRAWLER STORAGE

Service	Specification	Reference
Check radiator for coolant loss and antifreeze protection.	Section 10, Group 15
Fill fuel tank	Operator's Manual
Check crankcase oil level.	Operator's Manual
Relieve hydraulic pressure.	Stop engine, lower equipment to ground.	
Cover crawler for protection and cleanliness.	

BEFORE DELIVERING CRAWLER

Electrical System

Inspect electrolyte	Operator's Manual
Check alternator belt tension	3/4-inch deflection with 20 lb. force.	Operator's Manual
Clean terminals and check battery cable connections.	Operator's Manual

Cooling System

Inspect radiator for coolant loss.	Midway between core and filler neck.	Operator's Manual
Check antifreeze protection.	Operator's Manual

Track

Check track tension.	Section 80
Check front idler, track carrier roller and track roller oil level.	To oil level check hole.

Lubrication

Check crankcase oil level.	Between marks on dipstick.	Operator's Manual
Check transmission oil level.	Between marks on gauge.	Operator's Manual

BEFORE DELIVERING CRAWLER (Continued)

Service	Specification	Reference
Lubrication (Continued)		
Check final drive oil level.	To level of filler holes.	Operator's Manual
Check hydraulic reservoir oil level.	Halfway up on window glass	Operator's Manual
Check winch reservoir oil level.	To level of oil level hole.	Operator's Manual
Lubricate grease fittings.	Operator's Manual
Engine		
Check air cleaner.	Operator's Manual
Fill fuel tank and start engine.	Operator's Manual
Check operation of lights and gauges.	Operator's Manual
Check speed control linkage for free operation.	Section 20
Check engine idle speeds.	Section 20
Operation		
Check engine clutch operation.	Section 50
Check brake operation.	Section 60
Shift transmission through all ranges.	Operator's Manual
Check power take-off operation.	Operator's Manual
Check operation of attached equipment.	Operator's Manual
Check hydraulic system operation.	Operator's Manual
Check steering operation.	Section 60
Check bucket level indicator and electrical return-to-dig mechanism (if present).	Operator's Manual
General		
Tighten accessible nuts and cap screws.	Standard torque chart.	Section 10
Clean crawler and touch up paint.

DELIVERY SERVICE

A thorough discussion of the operation and service of a new machine at the time of delivery helps to assure complete customer satisfaction. Proper delivery should be an important phase of a dealer's program. A portion of the John Deere Delivery Receipt emphasizes the importance of proper delivery service.

It is a well-known fact that many complaints have arisen simply because the owner was not shown how to operate and service his new machine properly. Enough time should be devoted, at the customer's convenience, to introducing the owner to his new machine and explaining to him how to operate and service it.

Using the machine operator's manual as a guide, be sure that the owner understands these points thoroughly:

1. Controls and instruments.
2. How to start and stop the engine.
3. The importance of the break-in period.
4. How to use cast-iron ballast.
5. All functions of the hydraulic system.
6. The importance of safety.
7. The importance of lubrication and periodic services.

After explaining and demonstrating the above features, have the owner sign the delivery receipt and give him the operator's manual.

AFTER-SALES SERVICE

The purchaser of a new John Deere machine is entitled to a free inspection at some mutually agreeable time within the warranty period after the equipment has been "run in."

The purpose of this inspection is to make sure that the customer is receiving satisfactory performance from his machine. At the same time, the inspection should reveal whether or not the machine is being operated, lubricated, and serviced properly.

If the recommended after-sales service inspection is followed, the dealer can eliminate a needless volume of service work by preventing minor irregularities from developing into service problems later on. This will promote strong dealer-customer relations and give the dealer an opportunity to answer questions that may have arisen during the first few days of operation. During the inspection service, the dealer has the additional opportunity of promoting the possible sales of other new equipment.

The following is a recommended inspection program.

INSPECTION PROCEDURE

Service	Specification	Reference
Cooling System		
Check radiator coolant level.	Midway between core and filler neck	Operator's Manual
Check external surface of radiator core.	Operator's Manual
Check hoses and connections for leaks.
Fuel System		
Remove water and foreign matter from fuel filter sediment bowls.	Operator's Manual
Bleed fuel system.	Operator's Manual
Tighten loose connections and check entire system for leaks. Correct if necessary
Check air cleaner cup, element, and unloading valve. Clean element if necessary.	Operator's Manual

INSPECTION PROCEDURE—Continued

Service	Specification	Reference
Electrical System		
Check specific gravity of battery.	1.215 to 1.270 at 80°F	Operator's Manual
Check level of battery electrolyte.	To bottom of filler neck above plates.	Operator's Manual
Check alternator belt tension.	3/4-inch deflection with 20-pound force.	Operator's Manual
Start engine and check action of starter, lights and gauges.	Operator's Manual
Lubrication		
Check crankcase oil level.	Between marks on dipstick	Operator's Manual
Check transmission oil level.	Between marks on gauge.	Operator's Manual
Check final drive oil level.	To level of filler holes.	Operator's Manual
Check hydraulic reservoir oil level.	Halfway up on window glass.	Operator's Manual
Check winch reservoir oil level.	To level of oil level hole.	Operator's Manual
Lubricate grease fittings.	Operator's Manual
Engine		
Check valve clearance.	Intake-0.014 inch Exhaust-0.018 inch	Operator's Manual
Check engine speed under load and horsepower (Dynamometer test).	65 hp at 2500 rpm	FOS-ENGINES
General		
Check clutch pedal free travel.	Operator's Manual
Check transmission linkage adjustment.	Section 50
Check power take-off operation.	Operator's Manual
Check hydraulic system.	Section 70
Check steering clutches and brakes.	Section 60
Check track tension.	Section 80
Check winch operation.	Section 80
Tighten accessible nuts and cap screws.	Section 10, Group 25

Group 15

TUNE-UP AND ADJUSTMENT

Before tuning up a tractor, determine whether a tune-up will restore operating efficiency. When there is doubt, the following preliminary tests will help to determine if the engine can be tuned up. If the condi-

tion is satisfactory, proceed with the tune-up. Choose from the following procedures only those necessary to restore the unit.

PRELIMINARY ENGINE TESTING

Operation	Specification	Reference
Dynamometer Test (at 2500 engine rpm)	Compare with "SPECIFICATIONS"; compare with output after tune-up.	FOS-ENGINES
Compression Test	350 psi. The difference between cylinders should be no more than 50 psi.	FOS-ENGINES
Intake Vacuum Test	11 to 25 inches of water at fast idle	FOS-ENGINES
Engine Coolant Check	No air bubbles or oil film in radiator	FOS-ENGINES

ENGINE TUNE-UP

Operation	Specification	Reference
Air Intake System		
Service air cleaner and check system for leaks		FOS-ENGINES
Check restriction indicator operation	23 to 27 inches of water at 2500 rpm (full load)	FOS-ENGINES
Check crankcase breather for restriction		FOS-ENGINES
Exhaust System		
Check system for leaks		FOS-ENGINES
Check muffler and exhaust pipe for restriction		FOS-ENGINES
Cooling System		
Check radiator for coolant loss	Midway between core and filter neck	
Clean grille, radiator core and oil cooler case		FOS-ENGINES
Check pressure cap	6.25 to 7.50 psi release pressure	FOS-ENGINES
Clean and flush system, check thermostat.	Starts to Open	Fully Open
180°	177°F. to 184°F.	202°F.
205°	201°F. to 207°F.	213°F.

ENGINE TUNE-UP—Continued

Operation	Specification	Reference
Cylinder Head and Valves		
Tighten cylinder head cap screws	110 ft-lbs. torque, in sequence	Section 20, Group 10
Check valve clearance	Intake, 0.014-inch Exhaust, 0.018-inch	Section 20, Group 10
Fuel System		
Check fuel tank sump for water		FOS - ENGINES
Check fuel transfer pump pressure	3-1/2 to 4-1/2 psi at slow idle	FOS - ENGINES
Clean sediment bowls and change filter		FOS - ENGINES
Service injection nozzles		SM-2045
Injection Pump:		
Service and check timing		Section 30, Group 25
Advance		Section 30, Group 25
Adjust throttle linkage	Slow idle (rpm) 800 Fast idle (rpm) 2650	Section 20, Group 20
Lubrication System		
Check engine oil pressure	45 to 65 psi at 2500 rpm (180°F. to 220°F.)	Section 20, Group 10
Charging System		
Check battery specific gravity		FOS - ELECTRICAL SYSTEMS
Check electrolyte level		FOS - ELECTRICAL SYSTEMS
Check alternator belt tension	3/4-inch belt deflection with 20 lbs. force.	FOS - ELECTRICAL SYSTEMS
Check alternator output	22 amps.	FOS - ELECTRICAL SYSTEMS
Check alternator regulated voltage		FOS - ELECTRICAL SYSTEMS
Starting System		
Check start-safety switch operation		FOS - ELECTRICAL SYSTEMS
Check starter current draw	Approx. 150 amps.	Section 40, Group 15
Check operation of ammeter, oil pressure and air filter restriction indicator		FOS - ELECTRICAL SYSTEMS



Suggest:

If the above button click is invalid.

Please download this document

first, and then click the above link

to download the complete manual.

Thank you so much for reading