

**JOHN DEERE**  
**WORLDWIDE COMMERCIAL & CONSUMER**  
**EQUIPMENT DIVISION**

---

**CHAINSAWS**  
**CS36, CS40, CS46, CS52**  
**CS56, CS62, CS71, CS81**  
TM1917 AUG 2002  
**TECHNICAL MANUAL**



**JOHN DEERE**

North American Version  
Litho in U.S.A.

# INTRODUCTION

---

---

## Manual Description

This technical manual is written for an experienced technician and contains sections that are specifically for this product. It is a part of a total product support program.

The manual is organized so that all the information on a particular system is kept together. The order of grouping is as follows:

- Table of Contents
- Specifications and Information
- Identification Numbers
- Tools and Materials
- Component Location
- Schematics and Harnesses
- Theory of Operation
- Operation and Diagnostics
- Diagnostics
- Tests and Adjustments
- Repair
- Other

***NOTE: Depending on the particular section or system being covered, not all of the above groups may be used.***

The bleed tabs for the pages of each section will align with the sections listed on this page. Page numbering is consecutive from the beginning of the Safety section through the last section.

We appreciate your input on this manual. If you find any errors or want to comment on the layout of the manual please contact us.

**Safety**

**Specifications and Information**

**Engine**

---

# SAFETY

## Recognize Safety Information



This is the safety-alert symbol. When you see this symbol on your machine or in this manual, be alert to the potential for personal injury.

Follow recommended precautions and safe servicing practices.

## Understand Signal Words

A signal word - DANGER, WARNING, or CAUTION - is used with the safety-alert symbol. DANGER identifies the most serious hazards.

DANGER or WARNING safety signs are located near specific hazards. General precautions are listed on CAUTION safety signs. CAUTION also calls attention to safety messages in this manual.

## Replace Safety Signs

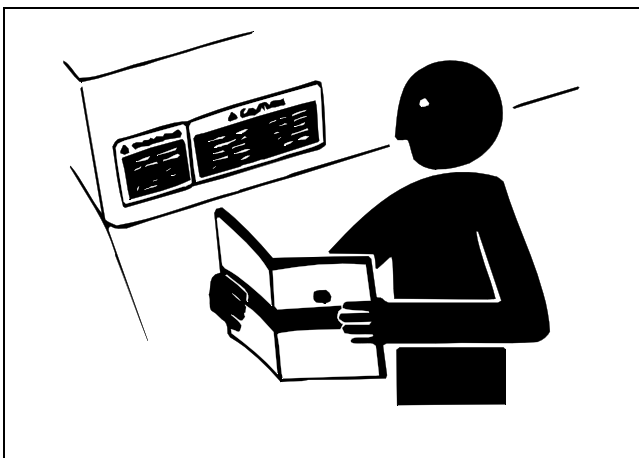

Replace missing or damaged safety signs. See the machine operator's manual for correct safety sign placement.

## Handle Fluids Safely - Avoid Fires

### Be Prepared For Emergencies

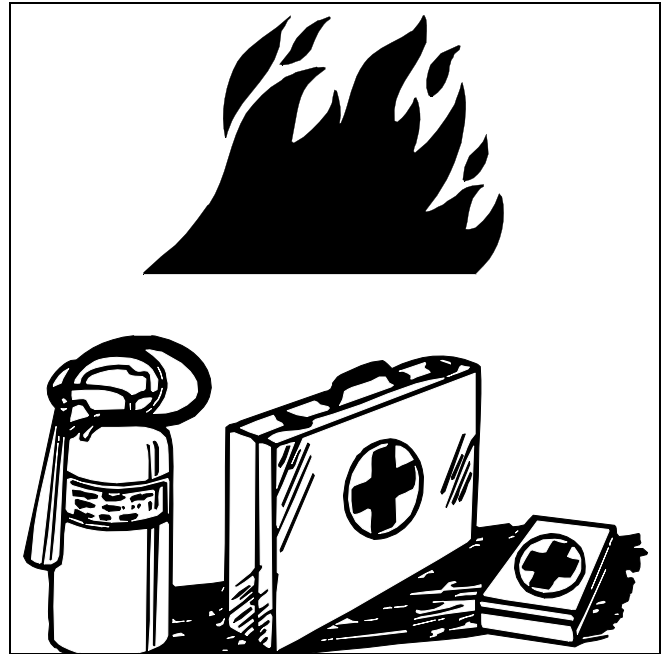

- When you work around fuel, do not smoke or work near heaters or other fire hazards.
- Store flammable fluids away from fire hazards. Do not incinerate or puncture pressurized containers.
- Make sure machine is clean of trash, grease, and debris.
- Do not store oily rags; they can ignite and burn spontaneously.
- Be prepared if a fire starts.
- Keep a first aid kit and fire extinguisher handy.
- Keep emergency numbers for doctors, ambulance service, hospital, and fire department near your telephone.

## Wear Protective Clothing

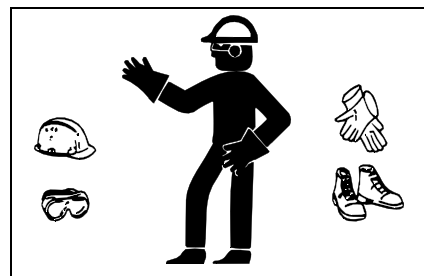

Wear close fitting clothing and safety equipment appropriate to the job.

# SAFETY

Prolonged exposure to loud noise can cause impairment or loss of hearing. Wear a suitable hearing protective device such as earmuffs or earplugs to protect against objectionable or uncomfortable loud noises.

Operating equipment safely requires the full attention of the operator. Do not wear radio or music headphones while operating machine.

## Service Machines Safely

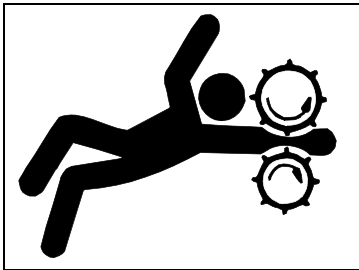

Tie long hair behind your head. Do not wear a necktie, scarf, loose clothing, or necklace when you work near machine tools or moving parts. If these items were to get caught, severe injury could result.

Remove rings and other jewelry to prevent electrical shorts and entanglement in moving parts.

## Use Proper Tools

Use tools appropriate to the work. Makeshift tools and procedures can create safety hazards. Use power tools only to loosen threaded parts and fasteners. For loosening and tightening hardware, use the correct size tools. **DO NOT** use U.S. measurement tools on metric fasteners. Avoid bodily injury caused by slipping wrenches. Use only service parts meeting John Deere specifications.

### Before working on the machine:

1. Lower all equipment to the ground.
2. Stop the engine
3. Hang a "DO NOT OPERATE" tag in operator station.

## Support Machine Properly and Use Proper Lifting Equipment

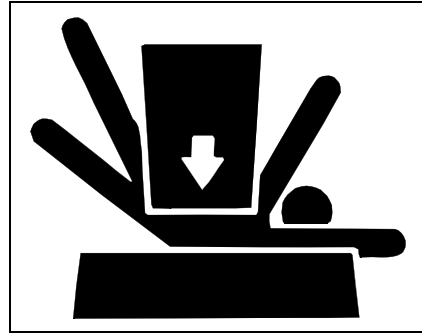

If you must work on a lifted machine or attachment, securely support the machine or attachment.

Do not support the machine on cinder blocks, hollow tiles, or props that may crumble under continuous load. Follow recommended procedures in this manual.

Follow recommended procedure for removal and installation of components in the manual.

## Work In Clean Area

### Before starting a job:

1. Clean work area and machine.
2. Make sure you have all necessary tools to do your job.
3. Have the right parts on hand.
4. Read all instructions thoroughly; do not attempt shortcuts.

## Using High Pressure Washers

Directing pressurized water at electronic/electrical components or connectors, bearings, hydraulic seals, fuel injection pumps or other sensitive parts and components may cause product malfunctions. Reduce pressure and spray at a 45 to 90 degree angle.

## Illuminate Work Area Safely

Illuminate your work area adequately but safely. Use a portable safety light for working inside the machine. Make sure the bulb is enclosed by a wire cage. The hot filament of an accidentally broken bulb can ignite spilled fuel or oil.

# SAFETY

## Work In Ventilated Area

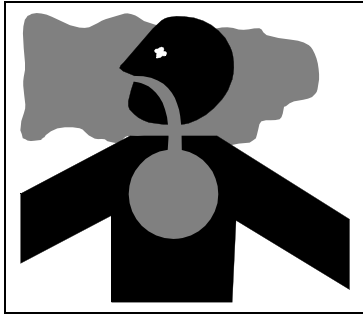

Engine exhaust fumes can cause sickness or death. If it is necessary to run an engine in an enclosed area, remove the exhaust fumes from the area by opening doors to get outside air into the area.

### Warning: California Proposition 65 Warning

Gasoline engine exhaust from this product contains chemicals known to the State of California to cause cancer, birth defects, or other reproductive harm.

### Remove Paint Before Welding or Heating

Avoid potentially toxic fumes and dust. Hazardous fumes can be generated when paint is heated by welding, soldering, or using a torch. Do all work outside or in a well ventilated area. Dispose of paint and solvent properly. Remove paint before welding or heating: If you sand or grind paint, avoid breathing the dust. Wear an approved respirator. If you use solvent or paint stripper, remove stripper with soap and water before welding. Remove solvent or paint stripper containers and other flammable material from area. Allow fumes to disperse at least 15 minutes before welding or heating.

### Avoid Injury From Rotating Blades

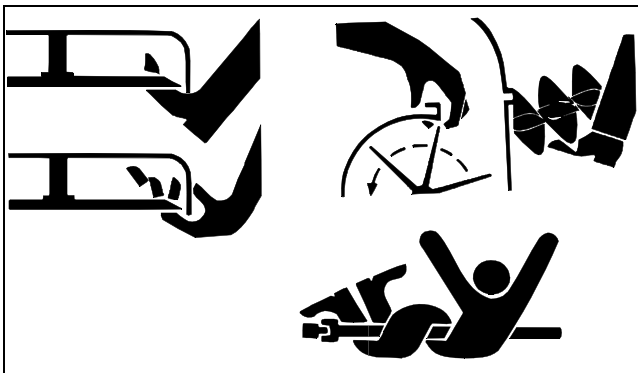

Keep hands and feet away while machine is running. Shut off power to service, lubricate, or remove blades.

## Handle Chemical Products Safely

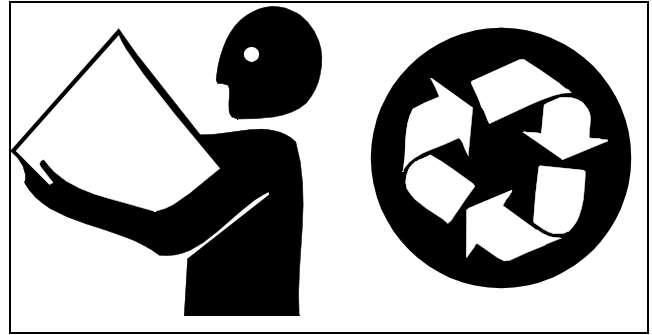

Direct exposure to hazardous chemicals can cause serious injury. Potentially hazardous chemicals used with John Deere equipment include such items as lubricants, coolants, paints, and adhesives.

A Material Safety Data Sheet (MSDS) provides specific details on chemical products: physical and health hazards, safety procedures, and emergency response techniques. Check the MSDS before you start any job using a hazardous chemical. That way you will know exactly what the risks are and how to do the job safely. Then follow procedures and recommended equipment.

### Dispose of Waste Properly

Improperly disposing of waste can threaten the environment and ecology. Potentially harmful waste used with John Deere equipment include such items as oil, fuel, coolant, brake fluid, filters, and batteries. Use leakproof containers when draining fluids. Do not use food or beverage containers that may mislead someone into drinking from them. Do not pour waste onto the ground, down a drain, or into any water source. Inquire on the proper way to recycle or dispose of waste from your local environmental or recycling center, or from your John Deere dealer.

## Live With Safety



Before returning machine to customer, make sure machine is functioning properly, especially the safety systems. Install all guards and shields.

# SPECIFICATIONS AND INFORMATION TABLE OF CONTENTS

---

---







## Table of Contents

<b>Fastener Torques</b> .....	<b>7</b>
Metric Fastener Torque Values .....	7
Inch Fastener Torque Values .....	8
<b>General Information</b> .....	<b>9</b>
2-Cycle Engines .....	9
Gasoline Storage.....	10
2-Cycle Gasoline Engine Oil .....	10
Alternative Lubricants .....	10
Synthetic Lubricants .....	10
Mixing Of Lubricants.....	10
<b>Identification Numbers</b> .....	<b>11</b>
Model CS36 and CS40.....	11
Model CS46 and CS52.....	11
Model CS56 and CS62.....	11
Model CS71 and CS81 .....	11

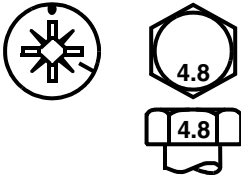
# SPECIFICATIONS AND INFORMATION FASTENER TORQUES

## Fastener Torques

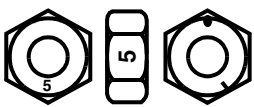
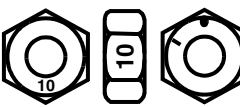
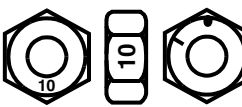
### Metric Fastener Torque Values

<b>Property Class and Head Markings</b>	<p>4.8</p> 	<p>8.8      9.8</p> 	<p>10.9</p> 	<p>12.9</p> 
<b>Property Class and Nut Markings</b>	<p>5</p> 	<p>10</p> 	<p>10</p> 	<p>12</p> 

SIZE	Class 4.8				Class 8.8 or 9.8				Class 10.9				Class 12.9			
	Lubricated a		Dry a		Lubricated a		Dry a		Lubricated a		Dry a		Lubricated a		Dry a	
	N•m	lb-ft	N•m	lb-ft	N•m	lb-ft	N•m	lb-ft	N•m	lb-ft	N•m	lb-ft	N•m	lb-ft	N•m	lb-ft
M6	4.8	3.5	6	4.5	9	6.5	11	8.5	13	9.5	17	12	15	11.5	19	14.5
M8	12	8.5	15	11	22	16	28	20	32	24	40	30	37	28	47	35
M10	23	17	29	21	43	32	55	40	63	47	80	60	75	55	95	70
M12	40	29	50	37	75	55	95	70	110	80	140	105	130	95	165	120
M14	63	47	80	60	120	88	150	110	175	130	225	165	205	150	260	109
M16	100	73	125	92	190	140	240	175	275	200	350	225	320	240	400	300
M18	135	100	175	125	260	195	330	250	375	275	475	350	440	325	560	410
M20	190	140	240	180	375	275	475	350	530	400	675	500	625	460	800	580
M22	260	190	330	250	510	375	650	475	725	540	925	675	850	625	1075	800
M24	330	250	425	310	650	475	825	600	925	675	1150	850	1075	800	1350	1000
M27	490	360	625	450	950	700	1200	875	1350	1000	1700	1250	1600	1150	2000	1500
M30	675	490	850	625	1300	950	1650	1200	1850	1350	2300	1700	2150	1600	2700	2000
M33	900	675	1150	850	1750	1300	2200	1650	2500	1850	3150	2350	2900	2150	3700	2750
M36	1150	850	1450	1075	2250	1650	2850	2100	3200	2350	4050	3000	3750	2750	4750	3500

DO NOT use these hand torque values if a different torque value or tightening procedure is given for a specific application. Torque values listed are for general use only and include a  $\pm 10\%$  variance factor. Check tightness of fasteners periodically. DO NOT use air powered wrenches.

Shear bolts are designed to fail under predetermined loads. Always replace shear bolts with identical grade.

Fasteners should be replaced with the same grade. Make sure fastener threads are clean and that you properly start thread engagement. This will prevent them from failing when tightening.

When bolt and nut combination fasteners are used, torque values should be applied to the NUT instead of the bolt head.

Tighten toothed or serrated-type lock nuts to the full torque value.







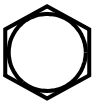

a "Lubricated" means coated with a lubricant such as engine oil, or fasteners with phosphate and oil coatings. "Dry" means plain or zinc plated (yellow dichromate - Specification JDS117) without any lubrication.

Reference: JDS - G200.

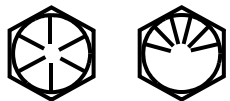

# SPECIFICATIONS AND INFORMATION FASTENER TORQUES

## Inch Fastener Torque Values

<b>SAE Grade and Head Markings</b>	1 or 2 <sup>b</sup> No Marks 	5    5.1    5.2 	8    8.2 
<b>SAE Grade and Nut Markings</b>	2 No Marks 	5  	8  

SIZE	Grade 1				Grade 2b				Grade 5, 5.1 or 5.2				Grade 8 or 8.2			
	Lubricated a		Dry a		Lubricated a		Dry a		Lubricated a		Dry a		Lubricated a		Dry a	
	N•m	lb-ft	N•m	lb-ft	N•m	lb-ft	N•m	lb-ft	N•m	lb-ft	N•m	lb-ft	N•m	lb-ft	N•m	lb-ft
1/4	3.7	2.8	4.7	3.5	6	4.5	7.5	5.5	9.5	7	12	9	13.5	10	17	12.5
5/16	7.7	5.5	10	7	12	9	15	11	20	15	25	18	28	21	35	26
3/8	14	10	17	13	22	16	27	20	35	26	44	33	50	36	63	46
7/16	22	16	28	20	35	26	44	32	55	41	70	52	80	58	100	75
1/2	33	25	42	31	53	39	67	50	85	63	110	80	120	90	150	115
9/16	48	36	60	45	75	56	95	70	125	90	155	115	175	130	225	160
5/8	67	50	85	62	105	78	135	100	170	125	215	160	215	160	300	225
3/4	120	87	150	110	190	140	240	175	300	225	375	280	425	310	550	400
7/8	190	140	240	175	190	140	240	175	490	360	625	450	700	500	875	650
1	290	210	360	270	290	210	360	270	725	540	925	675	1050	750	1300	975
1-1/8	470	300	510	375	470	300	510	375	900	675	1150	850	1450	1075	1850	1350
1-1/4	570	425	725	530	570	425	725	530	1300	950	1650	1200	2050	1500	2600	1950
1-3/8	750	550	950	700	750	550	950	700	1700	1250	2150	1550	2700	2000	3400	2550
1-1/2	1000	725	1250	925	990	725	1250	930	2250	1650	2850	2100	3600	2650	4550	3350

DO NOT use these hand torque values if a different torque value or tightening procedure is given for a specific application. Torque values listed are for general use only and include a ±10% variance factor. Check tightness of fasteners periodically. DO NOT use air powered wrenches.

Shear bolts are designed to fail under predetermined loads. Always replace shear bolts with identical grade.

Fasteners should be replaced with the same grade. Make sure fastener threads are clean and that you properly start thread engagement. This will prevent them from failing when tightening.

When bolt and nut combination fasteners are used, torque values should be applied to the NUT instead of the bolt

head.

Tighten toothed or serrated-type lock nuts to the full torque value.

a "Lubricated" means coated with a lubricant such as engine oil, or fasteners with phosphate and oil coatings. "Dry" means plain or zinc plated (yellow dichromate - Specification JDS117) without any lubrication.

b "Grade 2" applies for hex cap screws (Not Hex Bolts) up to 152 mm (6 in.) long. "Grade 1" applies for hex cap screws over 152 mm (6 in.) long, and for all other types of bolts and screws of any length.

Reference: JDS - G200

# SPECIFICATIONS AND INFORMATION GENERAL INFORMATION

## General Information

### 2-Cycle Engines

 **CAUTION: Avoid Injury! Gasoline is HIGHLY FLAMMABLE**, handle it with care. **DO NOT** refuel machine while:

- indoors, always fill gas tank outdoors;
- machine is near an open flame or sparks;
- engine is running, **STOP** engine;
- engine is hot, allow it to cool sufficiently first;
- smoking.

Help prevent fires:

- fill gas tank to bottom of filler neck only;
- be sure fill cap is tight after fueling;
- keep machine clean and in good repair-free of excess grease, oil, debris, and faulty or damaged parts;
- clean up any gas spills **IMMEDIATELY**;
- any storage of machines with gas left in tank should be in an area that is well ventilated to prevent possible igniting of fumes by an open flame or spark, this includes any appliance with a pilot light.

To prevent fire or explosion caused by **STATIC ELECTRIC DISCHARGE** during fueling:

- **ONLY** use a clean, approved **POLYETHYLENE PLASTIC** fuel container and funnel **WITHOUT** any metal screen or filter.



STOP ENGINE

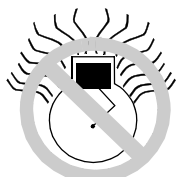

NO HOT ENGINE



NO SMOKING



NO OPEN FLAME OR SPARK



NO STATIC ELECTRIC DISCHARGE

To avoid engine damage:



**CAUTION: Avoid injury! California Proposition 65 Warning: Gasoline engine exhaust from this product contains chemicals known to the State of California to cause cancer, birth defects, or other reproductive harm.**



**CAUTION: Avoid Injury! DO NOT use METHANOL gasolines because METHANOL is harmful to the environment and to your health.**

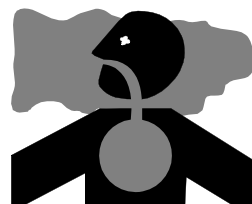

- **ONLY** use fresh, clean, unleaded gasoline with an octane rating (anti-knock index) of 87 or higher;
- Mix in John Deere 2-Cycle Engine Oil or its equivalent using a 50:1 fuel/oil mixture (see 2-Cycle Gasoline Engine Oil in this section).
- If John Deere 2-Cycle Engine Oil or its equivalent IS NOT being used, mix alternative 2-cycle engine oil to a 32:1 fuel/oil mixture (see 2-Cycle Gasoline Engine Oil in this section).

Use of alternative oxygenated, gasohol blended, unleaded gasoline is acceptable as long as:

- the ethyl or grain alcohol blends **DO NOT** exceed 10% by volume or
- methyl tertiary butyl ether (MTBE) blends **DO NOT** exceed 15% by volume.

# SPECIFICATIONS AND INFORMATION GENERAL INFORMATION

## Gasoline Storage

**IMPORTANT: Keep all dirt, scale, water or other foreign material out of gasoline.**

Keep gasoline stored in a safe, protected area. Storage of gasoline in a clean, properly marked ("UNLEADED GASOLINE") POLYETHYLENE PLASTIC container WITHOUT any metal screen or filter is recommended. DO NOT use de-icers to attempt to remove water from gasoline or depend on fuel filters to remove water from gasoline. Use a water separator installed in the storage tank outlet. BE SURE to properly discard unstable or contaminated gasoline. When storing machine or gasoline, it is recommended that you add **John Deere Gasoline Conditioner and Stabilizer (TY15977)** or an equivalent to the gasoline. BE SURE to follow directions on container and to properly discard empty container.

## 2-Cycle Gasoline Engine Oil

**IMPORTANT: Mix unleaded gasoline (87 octane or higher) and John Deere Premium 2-Cycle Engine Oil to a 50:1 ratio (3.8 L [1 U.S. gal] gasoline to 76 ml [2.6 oz] oil or 4.5 L [1 Imperial gal] gasoline to 90 ml [3.0 oz] oil).**

**If John Deere Premium 2-Cycle Engine Oil or its equivalent IS NOT being used mix unleaded gasoline and alternative 2-cycle engine oil to a 32:1 ratio (3.8 L [1 U.S. gal] gasoline to 119 ml [4.0 oz] oil or 4.5 L [1 Imperial gal] gasoline to 141 ml [4.8 oz] oil).**

The following John Deere Exact Mix oil is PREFERRED:

- **2-CYCLE AIR COOLED ENGINE OIL.**

Other oils may be used if above preferred John Deere oil is not available, provided they meet one of the following specifications:

- SAE Standard J2116 or Classifications TA, TB, TC, or TD;
- API Classification TC or higher;
- NMMA Classifications TC-W or TC-WII or higher;
- JASO Classifications FA, FB, or FC or higher;
- CEC Standard L-19-T-77.

**John Deere Dealers:** You may want to cross-reference the following publications to recommend the proper oil for your customers:

- Module DX,GAS2 in JDS-G135;
- Section 530, Lubricants & Hydraulics, of the John Deere Merchandise Sales Guide;
- Lubrication Sales Manual PI7032.

## Alternative Lubricants

**IMPORTANT: Use of alternative lubricants could cause reduced life of the component or void the warranty.**

Conditions in certain geographical areas outside the United States and Canada may require different lubricant recommendations than the ones printed in this technical manual or the operator's manual. Consult with your John Deere Dealer, or Sales Branch, to obtain the alternative lubricant recommendations.

## Synthetic Lubricants

Synthetic lubricants may be used in John Deere equipment if they meet the applicable performance requirements (industry classification and/or military specification) as shown in this manual.

The recommended air temperature limits and service or lubricant change intervals should be maintained as shown in the operator's manual, unless otherwise stated on lubricant label.

In general, avoid mixing different brands, grades or types of lubricants. Manufacturers blend additives in their lubricants to meet certain specifications and performance requirements. Mixing different lubricants can interfere with the proper functioning of these additives and lubricant properties which will downgrade their intended specified performance.

## Mixing Of Lubricants

In general, avoid mixing different brands, grades or types of lubricants. Manufacturers blend additives in their lubricants to meet certain specifications and performance requirements. Mixing different lubricants can interfere with the proper functioning of these additives and lubricant properties which will downgrade their intended specified performance.

**John Deere Dealers:** You may want to cross-reference the following publications to recommend the proper oil filter for your customers:

- Module DX, FILT in JDS-G135;
- Section 540, Lubricants & Hydraulics, of the John Deere Merchandise Sales Guide;
- Lawn & Grounds Care Tune-Up Guide PI672.

# SPECIFICATIONS AND INFORMATION IDENTIFICATION NUMBERS

## Identification Numbers

### Model CS36 and CS40



MX8610

Product identification plate (A) is located under the handle on the rear of the main case.

### Model CS46 and CS52

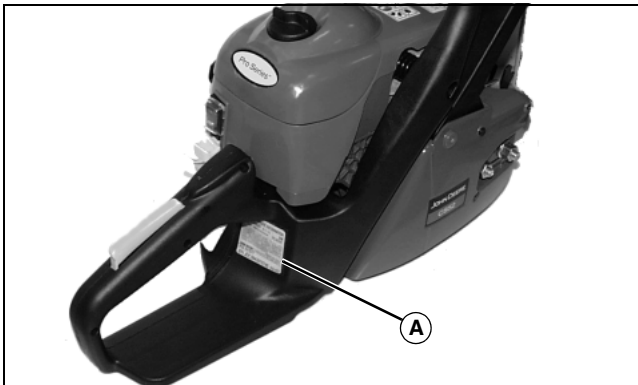

MX16303

Product identification plate (A) is located under the handle on the rear of the main case.

### Model CS56 and CS62



MX8611

Product identification plate (A) is located under the handle on the rear of the main case.

### Model CS71 and CS81

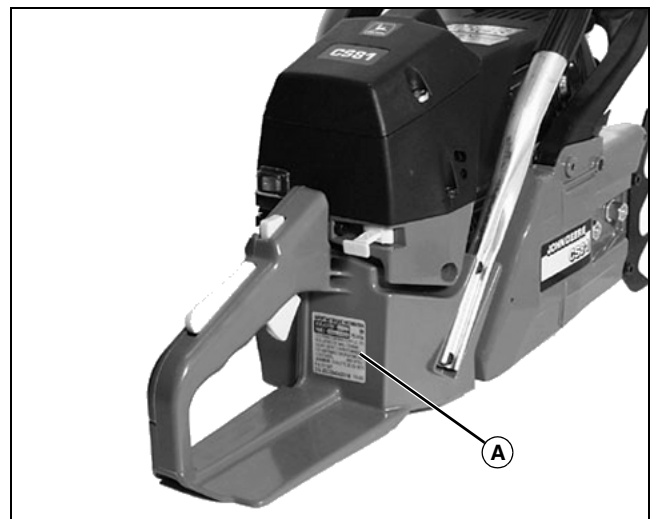

MX8612

Product identification plate (A) is located under the handle on the rear of the main case.

# ENGINE TABLE OF CONTENTS

<b>Table of Contents</b>	<b>Repair</b> ..... <b>38</b>
<b>Specifications</b> ..... <b>15</b>	Air Filter Removal and Installation - CS36, CS40..... 38
CS36 ..... 15	Air Filter Removal and Installation - CS46, CS52..... 39
CS40 ..... 16	Air Filter Removal and Installation - CS56, CS62, CS71, CS81 ..... 39
CS46 ..... 16	Cylinder Cover/Starter Removal and Installation - CS36, CS40 ..... 40
CS52 ..... 17	Cylinder Cover Removal and Installation - CS46, CS52..... 40
CS56 ..... 17	Cylinder Cover Removal and Installation - CS56, CS62, CS71, CS81 ..... 41
CS62 ..... 18	Oil Tank Vent Removal and Installation - All Models ..... 42
CS71 ..... 18	Fuel Tank Vent Removal and Installation - CS36, CS40, CS46, CS52..... 42
CS81 ..... 19	Fuel Tank Vent Removal and Installation - CS56, CS62, CS71, CS81 ..... 44
Tightening Torques - CS36, CS42. .... 19	Carburetor Removal and Installation - CS36, CS40..... 45
Tightening Torques - CS46, CS52 ..... 20	Carburetor Removal and Installation - CS46, CS52..... 45
Tightening Torques - CS56, CS62, CS71, CS81 ..... 21	Carburetor Removal and Installation - CS56, CS62..... 46
Special Tools..... 22	Carburetor Removal and Installation - CS71, CS81 ..... 46
Other Materials..... 22	Primer Bulb Removal and Installation - CS46, CS52..... 47
<b>Component Location</b> ..... <b>23</b>	Primer Bulb Removal and Installation - CS56, CS62..... 47
Component Location - CS36, CS40 ..... 23	Muffler Removal and Installation - CS36, CS40..... 48
Component Location - CS46, CS52 ..... 24	Muffler Removal and Installation - CS46, CS52..... 49
Component Location - CS56, CS62 ..... 25	Muffler Removal and Installation - CS56, CS62, CS71, CS81 ..... 50
Component Location - CS71, CS81 ..... 26	Throttle Trigger and Throttle Lockout Removal and Installation - CS36, CS40, CS46, CS52..... 51
<b>Diagnostics</b> ..... <b>27</b>	Throttle Trigger and Throttle Lockout Removal and Installation - CS56, CS62, CS71, CS81 ..... 51
Troubleshooting..... 27	Rear Handle Assembly Removal and Installation - CS36, CS40 ..... 52
<b>Tests and Adjustments</b> ..... <b>29</b>	Rear Handle Assembly Removal and Installation - CS46, CS52 ..... 52
Carburetor Pressure Test - All Models ..... 29	
Ignition Output Test - All Models ..... 29	
Spark Plug Gap - All Models ..... 30	
Ignition Switch Test - CS36, CS40, CS46, CS52 ..... 30	
Ignition Switch Test - CS56, CS62, CS71, CS81 ..... 30	
Ignition Module Test - All Models ..... 31	
Rotor Inspection - All Models ..... 32	
Carburetor Adjustments - All Models..... 32	
Compression Test - All Models ..... 34	
Fuel Filter Inspection - All Models ..... 34	
Fuel Pump and Fuel Line Integrity Test - All Models ..... 35	
Pulse Test - All Models..... 35	
Primer Bulb Test - CS46, CS52, CS56, CS62 ..... 36	
Oil Tank Vent Test - All Models..... 36	
Crankcase/Cylinder Pressure and Vacuum Test - All Models ..... 37	

# ENGINE TABLE OF CONTENTS

---

Rear Handle Assembly Removal and Installation - CS56, CS62, CS71, CS81 .....	53
Isolator Removal and Installation - CS56, CS62, CS71, CS81 .....	54
Starter Removal and Installation - CS36, CS40 .....	54
Starter Removal and Installation - CS46, CS52 .....	56
Starter Removal and Installation - CS56, CS62, CS71, CS81 .....	57
Rotor and Ignition Module Removal and Installation - CS36, CS40, CS46, CS52 .....	59
Rotor and Ignition Module Removal and Installation - CS56, CS62, CS71, CS81 .....	60
Chain Brake Removal and Installation - CS36, CS40 .....	61
Chain Brake Removal and Installation - CS46, CS52 .....	63
Chain Brake Removal and Installation - CS56, CS62, CS71, CS81 .....	64
Clutch Removal and Installation - All Models .....	66
Oil Pump Removal and Installation - CS36, CS40, CS46, CS52 .....	67
Oil Pump Removal and Installation - CS56, CS62, CS71, CS81 .....	68
Engine Disassembly and Inspection - CS36, CS40 .....	69
Engine Assembly - CS36, CS40 .....	70
Engine Disassembly and Inspection - CS46, CS52 .....	72
Engine Assembly - CS46, CS52 .....	74
Engine Disassembly and Inspection - CS56, CS62, CS71, CS81 .....	75
Engine Assembly - CS56, CS62, CS71, CS81 .....	76

# ENGINE SPECIFICATIONS

---

## Specifications

### CS36

Displacement	35.2 mm (2.15 cu in.)
Bore	38 mm (1.50 in.)
Stroke	31 mm (1.22 in.)
Starter Rope Length	3 x 900 mm (0.118 x 35.4 in.)
Idle rpm	2800
Maximum rpm	12,500 - 13,000
Break-In rpm (SEE NOTE)	12,200 - 12,500
Low Speed Screw Adjust	1-1/4 ± 1/8 Turn
High Speed Screw Adjust	1-1/4 ± 1/8 Turn
Throttle Control	Trigger Type with Safety Interlock
Fuel Capacity	400 mL (13.5 fl oz)
Bar Lubricant Capacity	220 mL (7.4 fl oz)
Vibration Isolation	Five Point - Three spring Mounts, Two Rubber Mounts
Guide Bar Length	12 in., 14 in., 16 in., 18 in.
Saw Chain Type	0.375 Pitch, 0.050 Gauge, Low Profile

**NOTE:** After five tanks of fuel for break in period, adjust to recommended rpm. After thirty tanks of fuel, adjust for maximum power. Factory carburetor settings are generally sufficient for the 5 to 6 tank break-in period. All engines should be broken-in rich due to tight engine tolerances. All engines will vary on break-in rpm and maximum rpm's. The listings provided are a general guideline. Verify that high speed screw settings are rich of optimum during the 5 to 6 tank break-in period.



**Suggest:**

**If the above button click is invalid.**

**Please download this document**

**first, and then click the above link**

**to download the complete manual.**

**Thank you so much for reading**



# ENGINE SPECIFICATIONS

## CS40

Displacement	39 cc (2.38 cu in.)
Bore	40 mm (1.57 in.)
Stroke	31 mm (1.22 in.)
Starter Rope Length	3 x 900 mm (0.118 x 35.4 in.)
Idle rpm	2800
Maximum rpm	12,500 - 13,000
Break-In rpm (SEE NOTE)	12,200 - 12,500
Low Speed Screw Adjust	1-1/4 ± 1/8 Turn
High Speed Screw Adjust	1-1/4 ± 1/8 Turn
Throttle Control	Trigger Type with Safety Interlock
Fuel Capacity	400 mL (13.5 fl oz)
Bar Lubricant Capacity	220 mL (7.4 fl oz)
Vibration Isolation	Five Point - Three spring Mounts, Two Rubber Mounts
Guide Bar Length	12 in., 14 in., 16 in., 18 in.
Saw Chain Type	0.375 Pitch, 0.050 Gauge, Low Profile

## CS46

Displacement	45.01 cc (2.75 cu in.)
Bore	42 mm (1.65 in.)
Stroke	32.5 mm (1.28 in.)
Starter Rope Length	3 x 960 mm (0.118 x 37.8 in.)
Idle rpm	2,700 ± 200
Maximum rpm	13,500 with Bar Chain
Break-In rpm (SEE NOTE)	13,000 ± 500 with Bar Chain
Low Speed Screw Adjust	1 ± 1/2 Factory Full Rich
High Speed Screw Adjust	1 ± 3/4 Factory Full Rich
Throttle Control	Trigger Type with Safety Interlock
Fuel Capacity	505 mL (17.1 oz)
Bar Lubricant Capacity	285 mL (9.6 oz)
Vibration Isolation	Five Point - Three Spring Mounts, Two Rubber Mounts
Guide Bar Length	14 in., 16 in., 18 in.
Saw Chain Type	0.325 Pitch, 0.050 Gauge

**NOTE:** After five tanks of fuel for break in period, adjust to recommended rpm. After thirty tanks of fuel, adjust for maximum power. Factory carburetor settings are generally sufficient for the 5 to 6 tank break-in period. All engines should be broken-in rich due to tight engine tolerances. All engines will vary on break-in rpm and maximum rpm's. The listings provided are a general guideline. Verify that high speed screw settings are rich of optimum during the 5 to 6 tank break-in period.