

# Group 10 PREDELIVERY, DELIVERY, AND AFTER-SALE SERVICES

## TEMPORARY UNIT STORAGE

After receiving your unit from the factory and before putting the machine into temporary storage, perform the following checks and services.

For long term storage (over 30 days) information, consult your JD300-B operator's manual.

1. Check battery electrolyte level and charge the battery, if necessary.
2. Check engine coolant level. Maintain midway between the radiator core and filler neck.
3. Fill the fuel tank.
4. Check crankcase oil level. Oil must be between marks on dipstick after machine has been shut down for 10 minutes.
5. Relieve hydraulic pressure by stopping engine, lowering bucket and backhoe and operating control levers and steering wheel until system fails to respond.
6. Reduce shipping pressure of all tires to the inflation pressure listed on page 10-10-2.

## PREDELIVERY SERVICE

Because of the shipping factors involved, plus extra finishing touches that are necessary to promote customer satisfaction, proper predelivery service is of prime importance to the dealer and the customer.

Use the following list when preparing a unit for delivery to the customer.

## 1. Air Cleaner

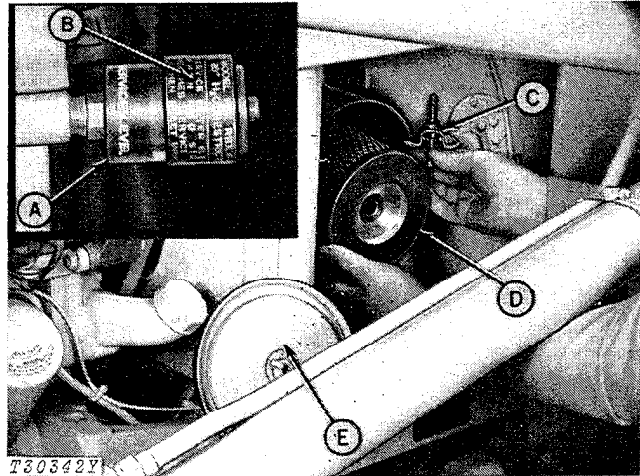

- A—Restriction Indicator      D—Element  
B—Red Signal                  E—Cover  
C—Wing Nut

Fig. 1-Air Cleaner

Check air filter restriction indicator (A). If red signal can be fully seen, remove element (D) and clean. Install a new element if necessary.

Element checked Yes    No

## 2. Radiator

Check engine coolant level.

**CAUTION:** Do not remove radiator filler cap unless the engine is cool. Then loosen the cap slowly to the stop to release pressure before removing the cap.

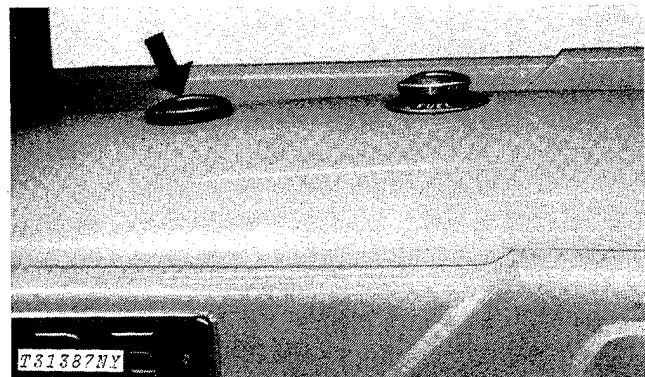

Fig. 2-Radiator Filler Cap

Maintain coolant level midway between the radiator core and the filler neck. If needed add clean soft water for warm weather or a solution of 50% clean water and 50% ethylene glycol (permanent type antifreeze with approved rust inhibitor) for cold weather. Tighten the filler cap.

Check cooling system for loose connections and leaks.

Coolant level checked  Yes  No

### 3. Batteries

Check battery electrolyte level. If distilled water is not available, use clean soft water. Avoid use of hard water. Remove foreign material from top of battery and coat terminals with petroleum jelly. Check vent holes in battery caps.

**IMPORTANT: Never add water to battery in freezing weather unless engine will be run 2 or 3 hours.**

Punch date code on battery.

Batteries checked  Yes  No

### 4. Tires

Check tire pressure with an accurate gauge having 1 psi (0.07 bar) graduations.

Inflate tires according to the chart below.

#### FRONT TIRES

Tire Size	Type	Ply Rating	Inflation Pressure psi (bar)
11L-15	I-1A	8	40 (2.8)
7.50/8.00-16	F-3	10	56 (4)

#### REAR TIRES

Tire Size	Type	PR	Inflation Pressure		
			With Little Ballast or No Rear-Mounted Equipment	With Moderate Ballast or Light Rear-Mounted Equipment	With Maximum Ballast or Heavy Rear-Mounted Equipment
14.9-24	R-3	6	20 psi (1.4 bar)	22 psi (1.5 bar)	24 psi (1.7 bar)
14.9-24	R-4	6	20 psi (1.4 bar)	22 psi (1.5 bar)	24 psi (1.7 bar)
17.5L-24	R-4	8	20 psi (1.4 bar)	22 psi (1.5 bar)	24 psi (1.7 bar)

Tire pressure checked  Yes  No

### 5. Crankcase Oil Level

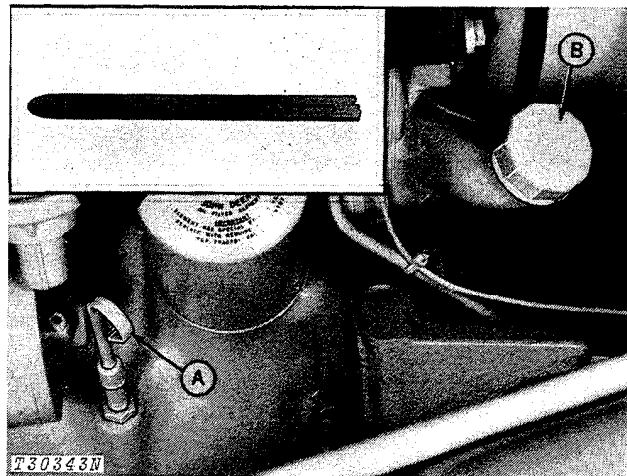

A—Dipstick

B—Oil Filler Cap

Fig. 3-Crankcase Oil Level

Check crankcase oil level with machine on level ground. (Allow a minimum of 10 minutes for the oil to drain down before checking.) If oil level is at or below bottom mark on dipstick, add oil specified on page 10-15-1 to bring oil level to between marks on dipstick. Do not operate engine with oil level below the bottom mark.

Crankcase oil level checked  Yes  No  
 Oil added \_\_\_\_\_ qts (L)

## 6. Transmission-Hydraulic Oil Level

Check transmission-hydraulic oil level.

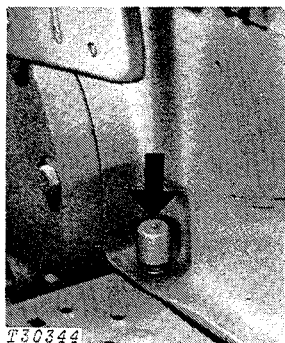

Fig. 4-Transmission-Hydraulic System Dipstick Resting On Top Threads

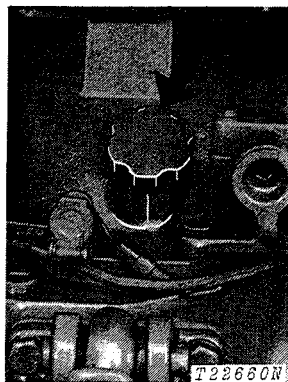

Fig. 5-Transmission-Hydraulic System Filler Cap

Run engine two to three minutes to fill oil circuits. Check oil level with machine on level ground, engine running at slow idle, rockshaft and any equipment lowered, reverser lever (if equipped) locked in neutral, parking brake engaged (if equipped), range shift lever in park, and clutch engaged. Remove dipstick and wipe oil off. Insert dipstick with cap resting on threads of tube (not screwed in place). If oil level is down to bottom mark on dipstick, add oil. Remove filler cap on rockshaft housing and add oil specified on page 10-15-1 to bring oil level to top mark on dipstick.

Oil level checked	Yes	No
Oil added		qts. (L)

## 7. Fuel Tank

Fill fuel tank with correct fuel. Check action of fuel gauge.

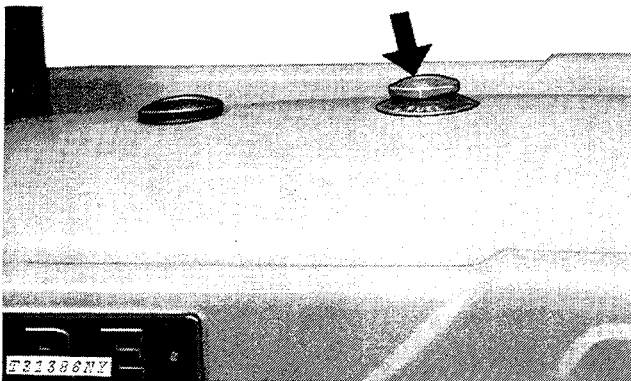
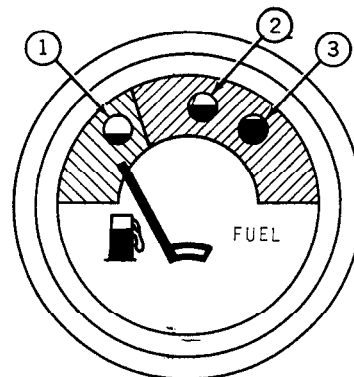

Fig. 6-Fuel Tank Filler Cap



1—Empty Tank                      2—Half Full Tank  
 3—Full Tank

Fig. 7-Fuel Gauge

Fuel tank filled	Yes	No
Fuel gauge checked	Yes	No

## 8. Grease Fittings

All grease fittings were lubricated and checked before the unit left the factory. However, to insure customer satisfaction, check each fitting shown on the following pages. Lubricate, if necessary, with John Deere Multi-Purpose Grease or an equivalent.

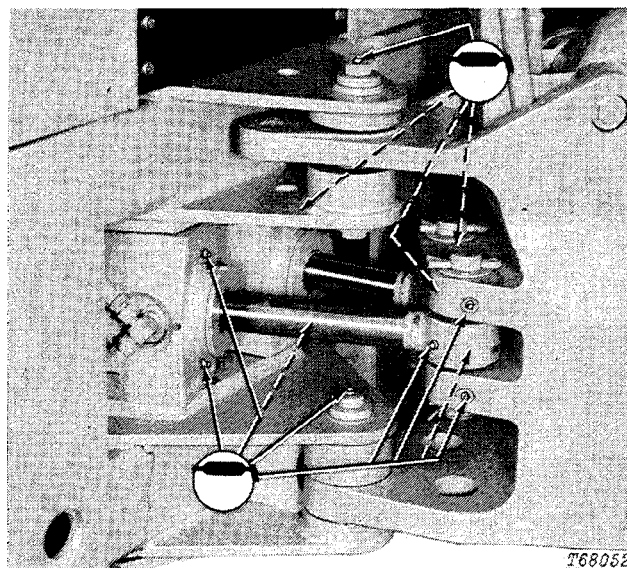
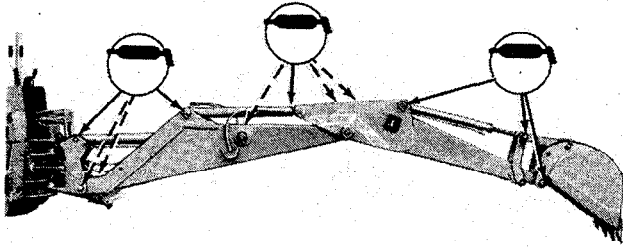

Fig. 8-Backhoe Pivot Points (12 points)

Lubrication required	Yes	No
----------------------	-----	----



T68051Y

Fig. 9-Backhoe Boom Pivots (11 points)

Lubrication required Yes No

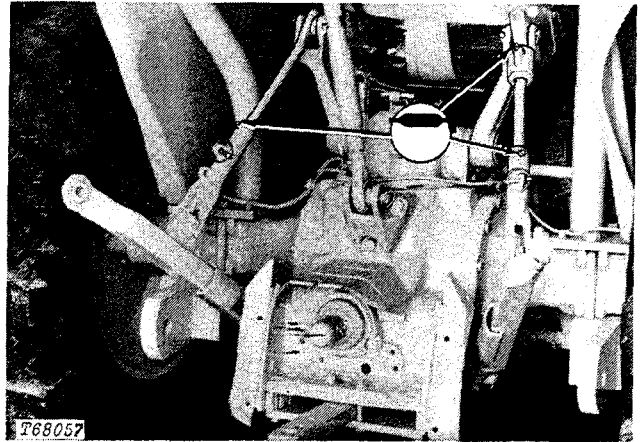

T68057

Fig. 12-3-Point Hitch (3 points)

Lubrication required Yes No

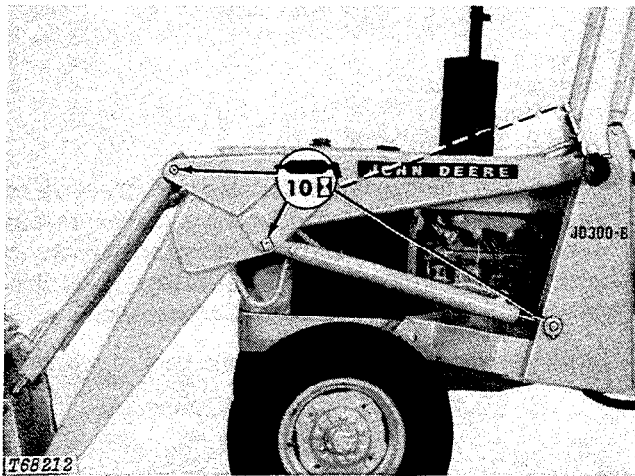

T68212

Fig. 10-Loader Pivot Points (4 points)

Lubrication required Yes No

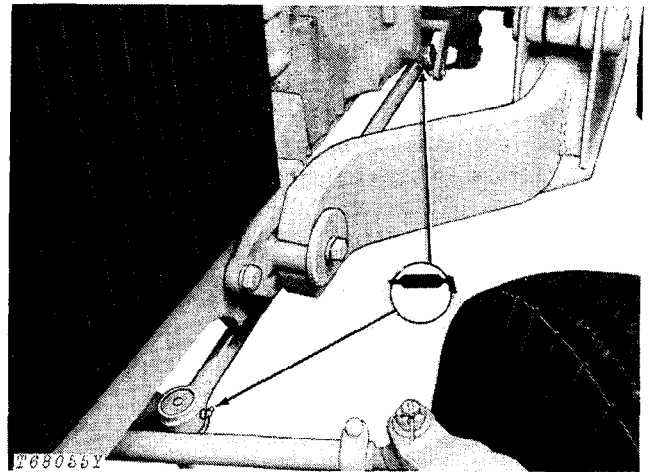

T69055Y

Fig. 13-Drag Links (2 points)

Lubrication required Yes No

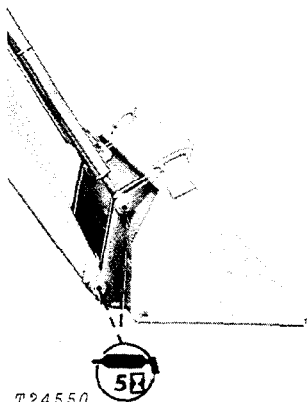

T24550

Fig. 11-Bucket Pivots (4 points)

Lubrication required Yes No

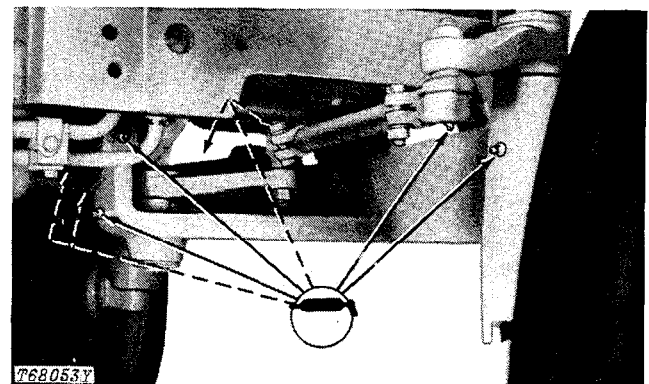

T68053Y

Fig. 14-Front Axle Pivot Points (8 points)

Lubrication required Yes No

## 9. Air Intake Hoses

Check clamps on hoses connecting air cleaner and engine. Tighten hose clamps where necessary. Inspect hoses for cracks.

Intake hoses checked Yes No

## 10. Alternator-Fan Belt Tension

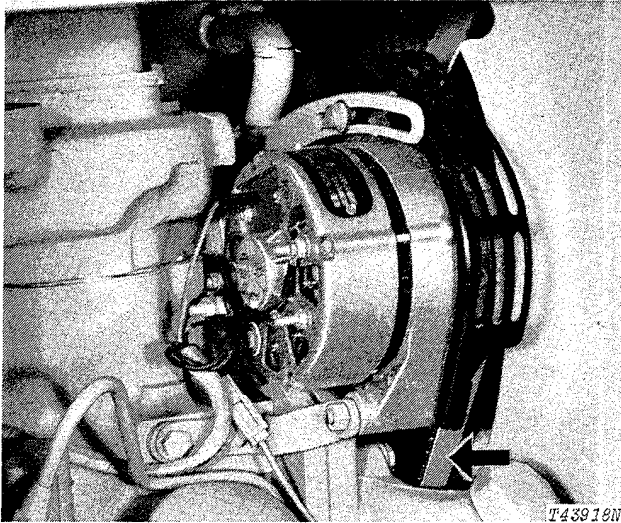

Fig. 15-Alternator-Fan Belt Tension

Check alternator belt tension. Loosen the alternator bracket and adjusting cap screws. Apply outward force to the FRONT alternator frame until 20 lb (9 kg) force on the belt midway between the pulleys will deflect the belt 3/4 inch (19 mm). If a strand tension gauge is used, strand tension must be 90 lb. (41 kg).

**IMPORTANT: Do not pry on the rear half of the alternator housing.**

Belt tension checked Yes No

## 11. Engine Speeds

Check engine speeds.

Slow idle - 825 rpm  
 Fast idle - 2650 rpm hand throttle  
 2800 rpm foot throttle

If adjustment is needed, see page 10-10-20.

Engine speeds checked Yes No

## 12. Fuel Filter

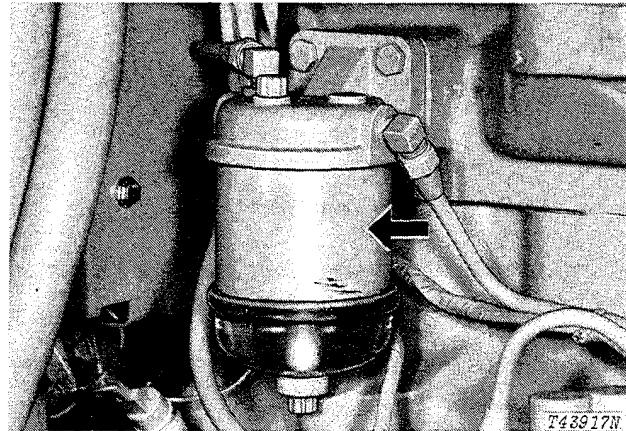

Fig. 16-Fuel Filter

Check fuel filter for sediment and drain if necessary.

Fuel filter checked Yes No

## 13. Indicator Lights and Gauges

Check operation of indicator lights.

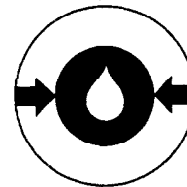

Fig. 17-Engine Oil Pressure Indicator Light

If light glows red when engine is running, stop engine immediately and determine cause.

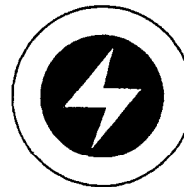
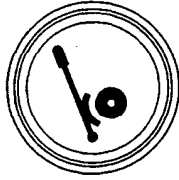

Fig. 18-Alternator Indicator Light

Light glows red when alternator is not charging. When light goes on with engine running, stop engine and determine cause.



T62798N

Fig. 19-Parking Brake Indicator

Indicator light will glow when key switch is on and parking brake is engaged.

Check operation of the engine coolant temperature gauge.

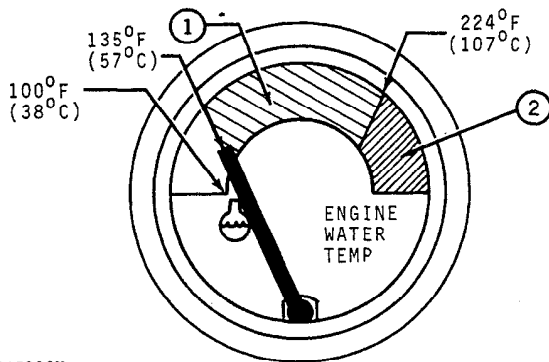

T43920N

1—Operating Range                      2—Overheat Range

Fig. 20-Water Temperature Gauge

NOTE: Fuel gauge is on page 10-10-3.

Indicator lights and gauges checked                      Yes    No

### 14. Reverser

The reverser unit allows the operator to change the direction of travel "on the go" without declutching or shifting gears.

Note and correct any reverser malfunctions.

See page 10-10-22 for reverser speed of shift adjustment.

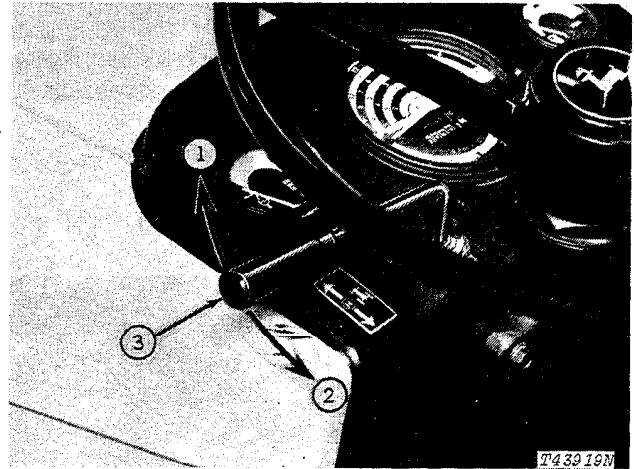

1—Forward                                      2—Reverse  
 3—Neutral

Fig. 21-Reverser Lever

Reverser checked                                      Yes    No

### 15. Differential Lock

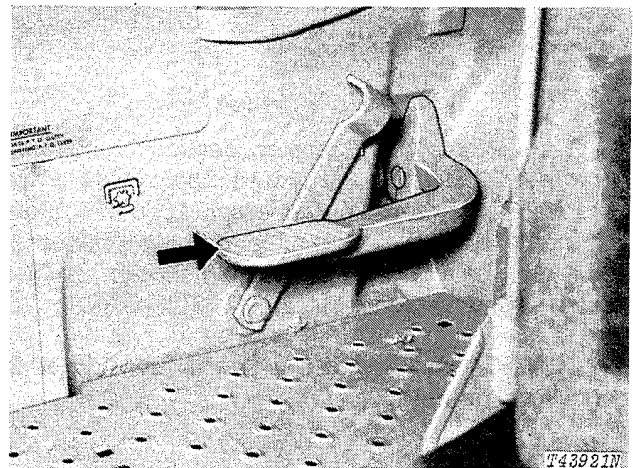

Fig. 22-Differential Lock Pedal

Check the differential lock operation.

While driving straight ahead push down the differential lock pedal. Hold the pedal down. Turn the steering wheel slightly. The operator will feel steering resistance if differential lock is working correctly.

The differential lock will automatically disengage when the pedal is released if traction for both rear wheels is equal. Unequal traction will keep the lock engaged.

Differential lock checked                                      Yes    No



**Suggest:**

**If the above button click is invalid.**

**Please download this document**

**first, and then click the above link**

**to download the complete manual.**

**Thank you so much for reading**