

Product: MOTOR GRADER
 Model: 140M MOTOR GRADER B9M
 Configuration: 140M Motor Grader B9M00001-UP (MACHINE)

Disassembly and Assembly 140M Motor Grader

Media Number -KENR6424-07

Publication Date -01/04/2015

Date Updated -06/04/2015

i05508509

Circle - Install

SMCS - 6154-012

Installation Procedure

Table 1

Required Tools			
Tool	Part Number	Part Description	Qty
A	138-7574	Link Bracket	2
B	1P-1831	Adapter	1
	4C-9633	Puller Stud	1
	9U-6833	Nut	1
	5P-8250	Washer	1
	5P-4197	Spacer	1
	6V-3160	Double Acting Cylinder	1
	350-7768	Electric Hydraulic Pump Gp (115V)	1
	350-7769	Electric Hydraulic Pump Gp (230V)	1
C	4C-6486	Stand	1
	8S-7621	Tube	1
	8S-7615	Pin	1
	8S-8048	Saddle	1

NOTICE

Care must be taken to ensure that fluids are contained during performance of inspection, maintenance, testing, adjusting, and repair of the product. Be prepared to collect the fluid with suitable containers before opening any compartment or disassembling any component containing fluids.

Refer to Special Publication, PERJ1017, "Dealer Service Tool Catalog" for tools and supplies suitable to collect and contain fluids on Cat[®] products.

Dispose of all fluids according to local regulations and mandates.



Hydraulic oil pressure can remain in the hydraulic system on this machine after the engine and pump have been stopped. Serious injury can result if this pressure is not released before any service is done on the hydraulic systems. In order to prevent possible injury, release the hydraulic system pressure before working on any fitting, hose, or hydraulic component.

Lower all attachments to the ground before service is started. If the hydraulic system must be serviced, tested, or adjusted with the attachment in the raised position, the attachments and lift cylinders must be supported properly.

Always move the machine to a location away from the travel of other machines. Be sure that other personnel are not near the machine when the engine is running and tests or adjustments are being made.



When you are using hydraulic cylinders and puller studs, always ensure that the rated capacity of the puller stud meets or exceeds the rated capacity of the hydraulic cylinder. If the puller stud does not meet or exceed the rated capacity of the hydraulic cylinder, a sudden failure of the puller stud could occur. The sudden failure of the puller stud could result in personal injury or death.

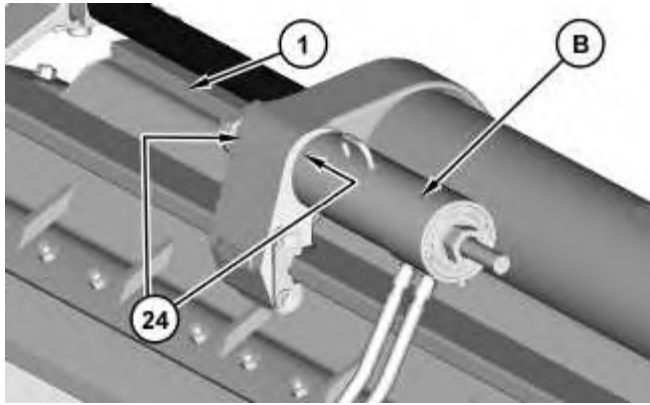

Illustration 1

g01402122

1. Lower the temperature of two bearings (24). Use Tooling (B) in order to install two bearings (24) (not shown) into blade (1). Repeat this step for the opposite side.

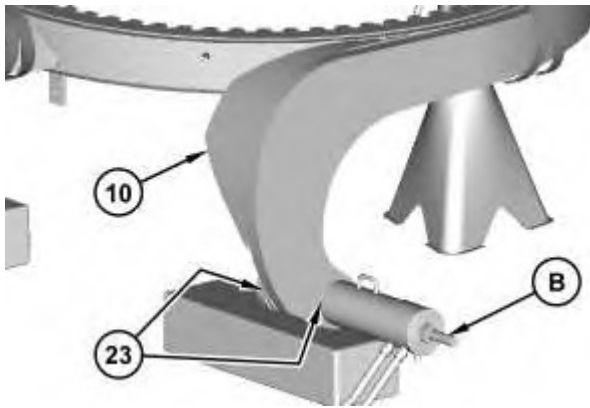

Illustration 2

g01402120

2. Lower the temperature of two bearings (23). Use Tooling (B) in order to install two bearings (23) (not shown) in circle assembly (10). Repeat this step for the opposite side.

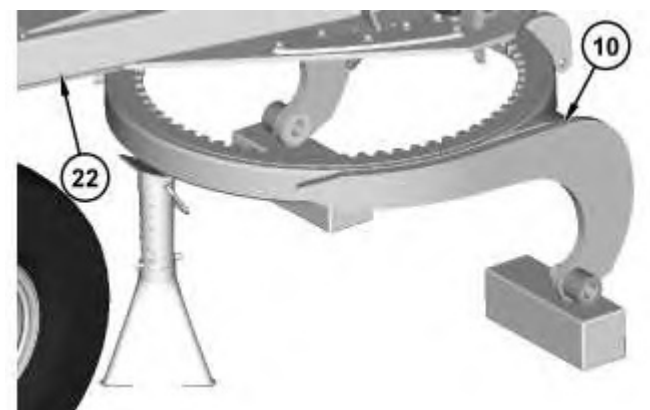

Illustration 3

g01402117

3. Start the machine. Lower drawbar (22) onto circle assembly (10).

**Thank you very much
for your reading.**

**Please click here to buy
After you pay.**

**Then, you can
download the complete
manual instantly.
No waiting.**