

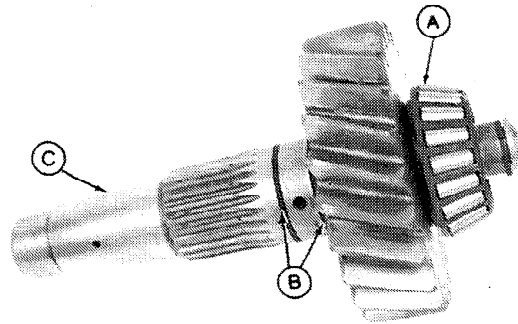

CAUTION: DO NOT heat oil over 182° (360°F). Oil fumes or oil can ignite above 193°C (360°F). Use a thermometer. **DO NOT** allow a flame or heating element to come in direct contact with the oil. Heat the oil in a well-ventilated area.

14. Heat bearing cones to 96°C (203°F) and install on clutch driven shaft.

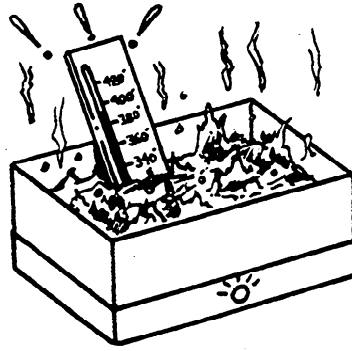

6AH;T81191, T6833AX T48;0350 J390 130189

15. Test clutch pack by holding air test plug firmly in end of shaft. Apply just enough air pressure to feel piston move. If piston does not move, disassemble and inspect clutch pack.

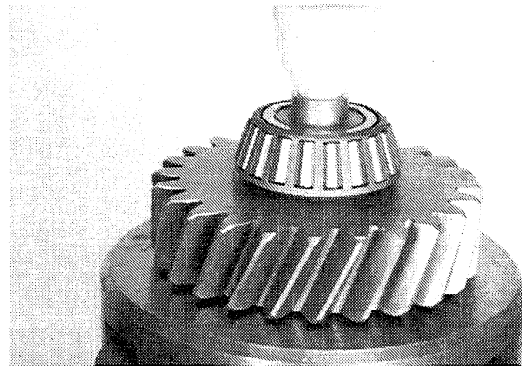

6NA;T6129AB T48;0350 J391 201288

16. Install a new sealing ring (B).

17. Press on retainer (A) using a 23 mm disk from driver set. Sealing ring must turn freely after installing retainer.

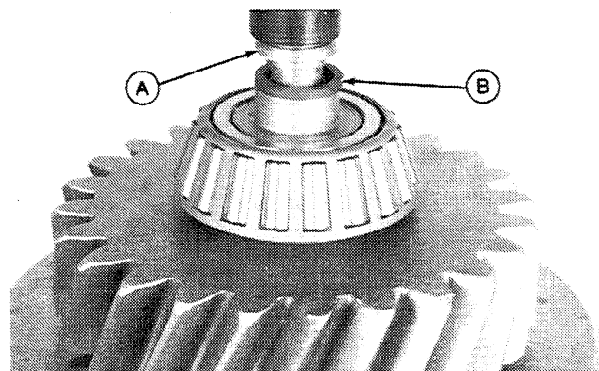

6NA;T6129AH T48;0350 J392 130189

Gear, Shafts, Bearings, And Power Shift Clutch

18. Install bearing cup in transfer case using 64 and 48 mm disks.

19. Install clutch pack assembly in transfer case.

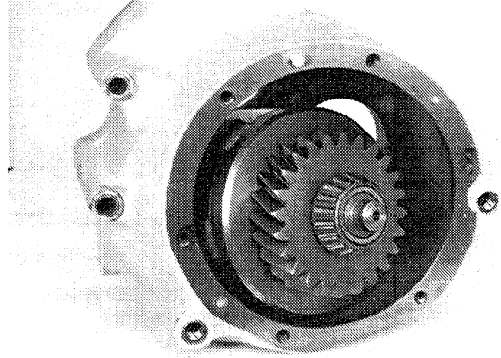

6NA;T6105AP T48;0350 J393 130189

20. Install bearing cups (A) using 51 and 68 mm disks.

21. Install O-ring (B) and shims (C).

22. Install and tighten solenoid (D) to 22—27 N·m (16—20 lb-ft).

23. Install and tighten cover cap screws 75 N·m (56 lb-ft).

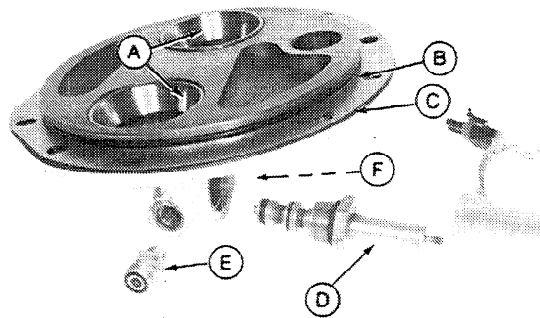

A—Bearing Cups
B—O-Rings
C—Shims

D—Solenoid
E—Fitting
F—Pressure Switch

6AH;T6833AU T48;0350 J394 201288

24. Check clutch pack end play using a dial indicator.

SPECIFICATION

Clutch Pack End Play 0.05—0.10 mm
(0.002—0.004)

To adjust end play, install or remove shims from under the cover.

25. With clutch pack end play set to specification, remove cover. Keep shims together for reassembly.

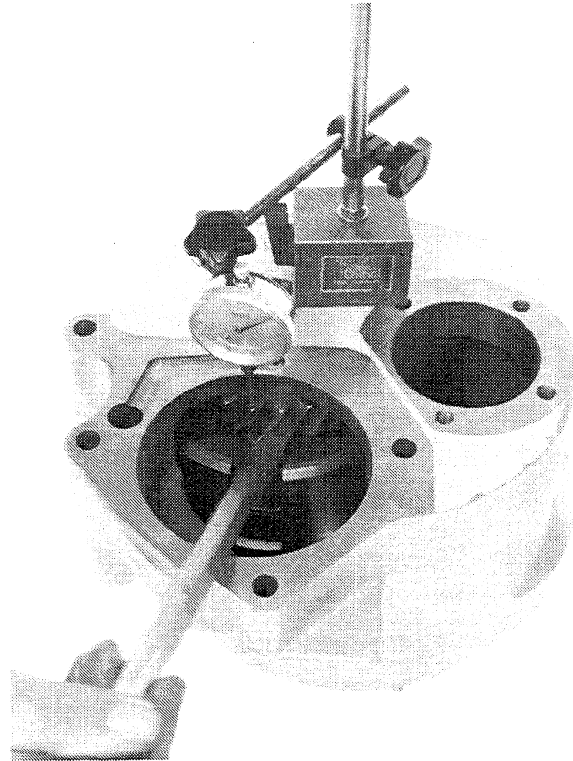

6NA;T6129AF T48;0350 J395 130189

26. Install bearing cup (D) using 74 mm and 59 mm disks.

27. Install parts (A—C).

A—Shims
B—O-Ring

C—Seal
D—Bearing Cup

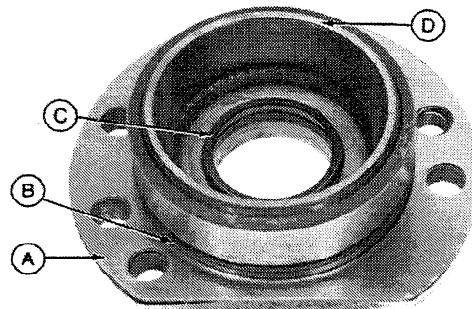

6AH;T6833AV T48;0350 J396 201288



Suggest:

If the above button click is invalid.

Please download this document

first, and then click the above link

to download the complete manual.

Thank you so much for reading