

Product: BACKHOE LOADER

Model: 444F BACKHOE LOADER JXR

Configuration: 444F Backhoe Loader Side Shift JXR00001-UP (MACHINE) POWERED BY C4.4 Engine

Disassembly and Assembly C4.4 Engines for Caterpillar Built Machines

Media Number -UENR0602-11

Publication Date -01/08/2013

Date Updated -25/10/2017

i05016731

Crankshaft Front Seal - Remove and Install

SMCS - 1160-010

Removal Procedure

Table 1

Required Tools			
Tool	Part Number	Part Description	Qty
A	367-3534	Oil Seal Removal & installer Tool	1

Start By:

- Remove the crankshaft pulley. Refer to Disassembly and Assembly, "Crankshaft Front Pulley- Remove and Install" for the correct procedure.

NOTICE

Keep all parts clean from contaminants.

Contaminants may cause rapid wear and shortened component life.

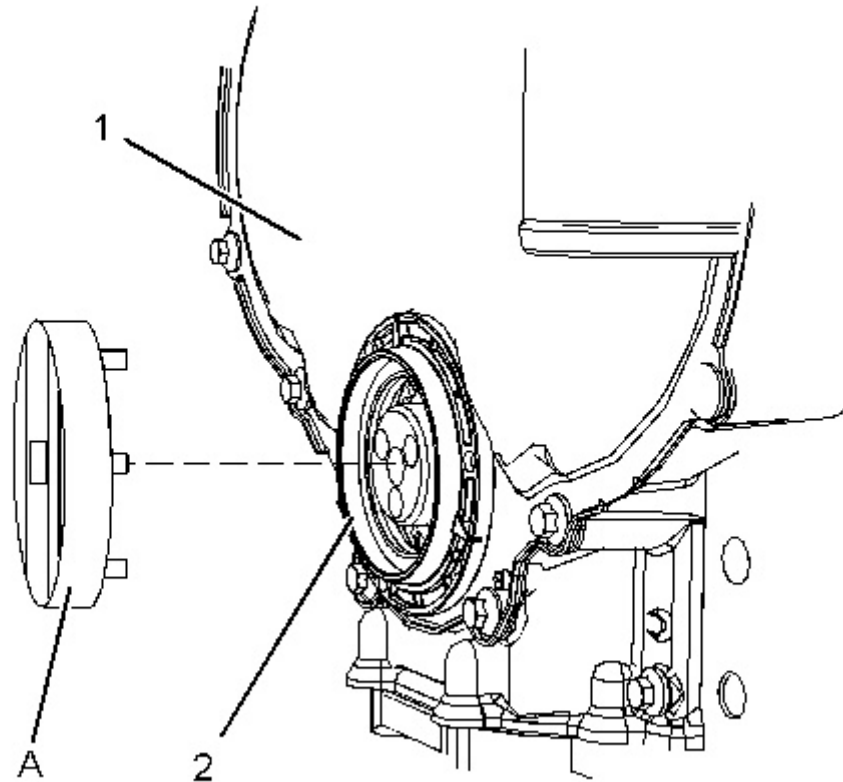

Illustration 1

g02445196

1. Align Tooling (A) onto crankshaft front seal (2).
2. Turn Tooling (A) in a counterclockwise direction and remove crankshaft front seal (2) from front cover (1).

Installation Procedure

Table 2

Required Tools			
Tool	Part Number	Part Description	Qty
A	367-3534	Oil Seal Removal & installer Tool	1
B	-	Loctite 5900	-

NOTICE

Keep all parts clean from contaminants.

Contaminants may cause rapid wear and shortened component life.

1. Ensure that the front cover is clean and free from damage.

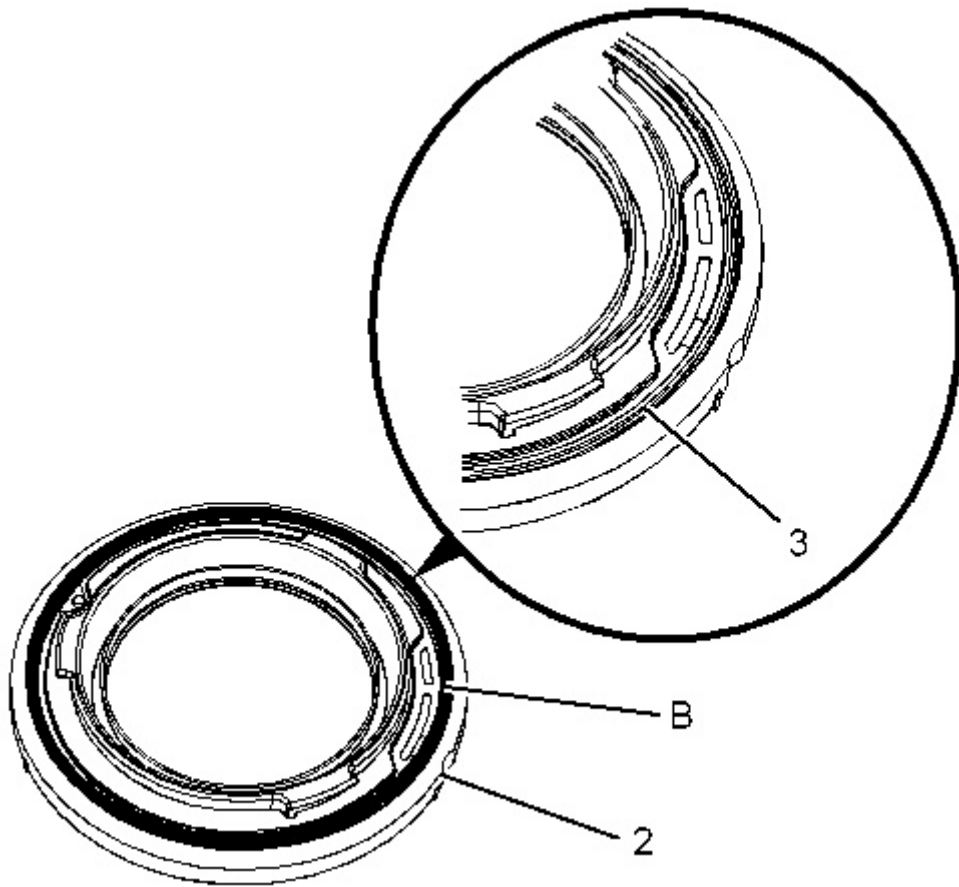

Illustration 2

g02445217

**Thank you very much
for your reading.**

**Please click here to buy
After you pay.**

**Then, you can
download the complete
manual instantly.
No waiting.**