

Product: BACKHOE LOADER

Model: 416F2 BACKHOE LOADER HWB

Configuration: 416F2 Center Pivot Backhoe Loader HWB00001-UP (MACHINE) POWERED BY C4.4 Engine

Disassembly and Assembly C4.4 Engines for Caterpillar Built Machines

Media Number -UENR4516-11

Publication Date -01/06/2015

Date Updated -29/10/2018

i05820268

Inlet and Exhaust Valves - Remove and Install

SMCS - 1105-010

Removal Procedure

Table 1

Required Tools			
Tool	Part Number	Part Description	Qty
A	9U-6195	Valve Spring Compressor	1
	268-1969	Adapter	1
	276-1221	Head	1

Start By:

- Remove the cylinder head. Refer to Disassembly and Assembly, "Cylinder Head - Remove" for the correct procedure.

NOTICE

Keep all parts clean from contaminants.

Contaminants may cause rapid wear and shortened component life.

- Clean the bottom mating surface of the cylinder head. Check the depth of the valves below the face of the cylinder head before the valve springs are removed. Refer to Specifications, "Cylinder Head Valves" for the correct dimensions.

2. Place a temporary identification mark on the heads of the valves in order to identify the correct position.

Note: Inlet valves have a recess in the center of the head.

3. Use a suitable lifting device to position the cylinder head with the valve springs upward. The weight of the cylinder head is approximately 65 kg (143 lb).

Note: Ensure that the cylinder head is kept on a clean, soft surface in order to prevent damage to the machined face.

WARNING

Personal injury can result from being struck by parts propelled by a released spring force.

Make sure to wear all necessary protective equipment.

Follow the recommended procedure and use all recommended tooling to release the spring force.

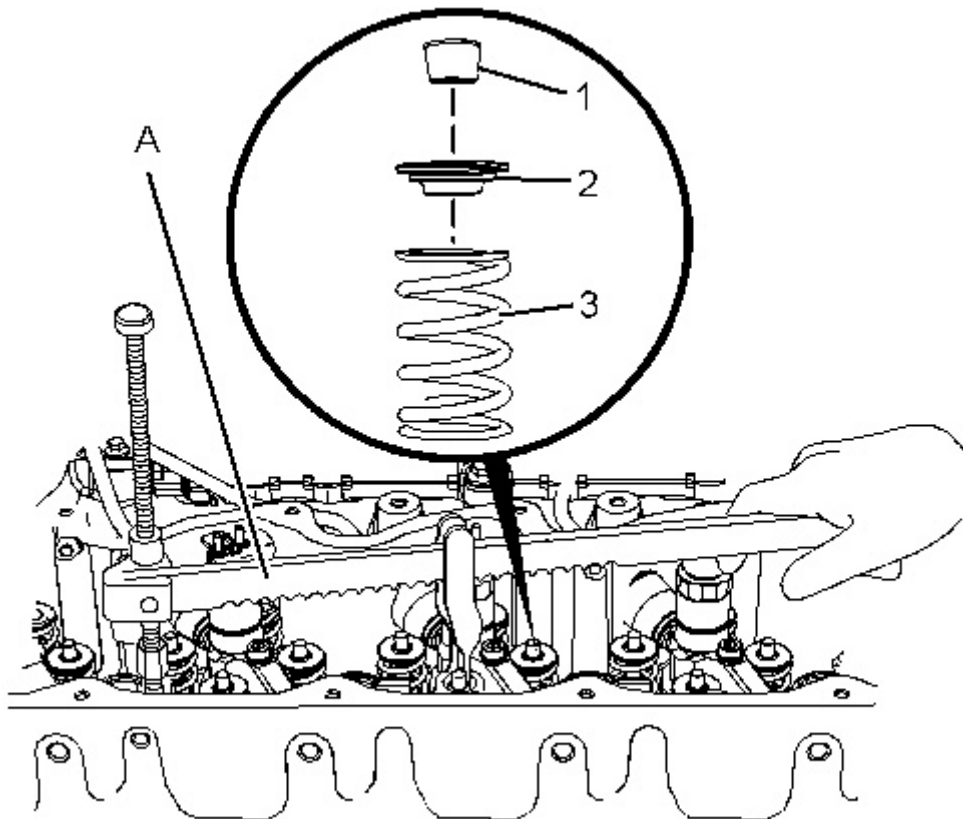

4. Install Tooling (A) in position on the cylinder head in order to compress appropriate valve spring (3).

NOTICE

Ensure that the valve spring is compressed squarely or damage to the valve stem may occur.

5. Apply sufficient pressure to Tooling (A) in order to remove valve keepers (1).

Note: Do not compress the spring so that valve spring retainer (2) touches valve stem seal (4).

6. Slowly release pressure on Tooling (A).

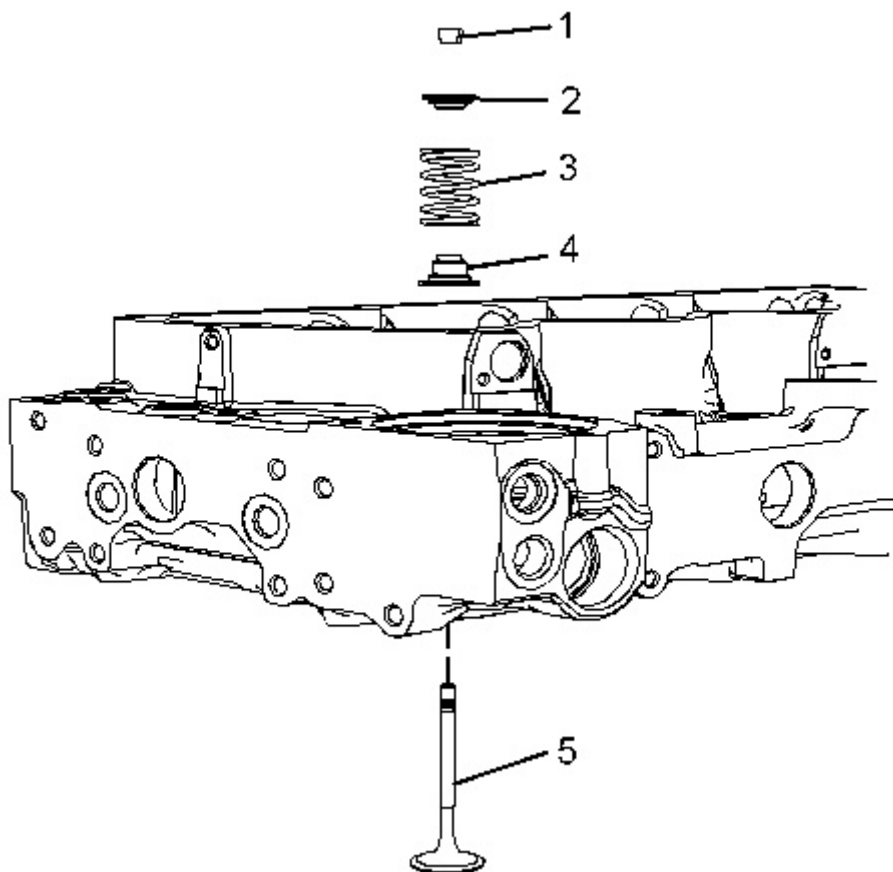

Illustration 2

g02511676

7. Place a temporary identification mark on valve spring (3) in order to identify the correct position.
8. Remove valve spring retainer (2). Remove valve spring (3).
9. Repeat Step 4 through Step 8 for the remaining valves.

**Thank you very much
for your reading.**

**Please click here to buy
After you pay.**

**Then, you can
download the complete
manual instantly.
No waiting.**