

Product: MOTOR GRADER

Model: 140M 3 MOTOR GRADER N9M

Configuration: 140M Series 3 Motor Grader N9M00001-UP (MACHINE) POWERED BY C9.3 Engine

Disassembly and Assembly

12M Series 3, 140M Series 3 and 160M Series 3 Motor Graders Machine Systems

Media Number -UENR3488-02

Publication Date -01/09/2018

Date Updated -24/09/2018

i02872843

Bank Valve - Remove - Front Frame

SMCS - 5051-011

Removal Procedure

Table 1

Required Tools			
Tool	Part Number	Part Description	Qty
A	311-1362	Vacuum Cap	1
B	138-7573	Link Bracket	2

NOTICE

Keep all parts clean from contaminants.

Contaminants may cause rapid wear and shortened component life.

NOTICE

Care must be taken to ensure that fluids are contained during performance of inspection, maintenance, testing, adjusting, and repair of the product. Be prepared to collect the fluid with suitable containers before opening any compartment or disassembling any component containing fluids.

Refer to Special Publication, PERJ1017, "Dealer Service Tool Catalog" for tools and supplies suitable to collect and contain fluids on Cat[®] products.

Dispose of all fluids according to local regulations and mandates.

Note: Put identification marks on all lines, on all hoses, on all wires, and on all tubes for installation purposes. Plug all lines, hoses, and tubes. This helps to prevent fluid loss and this helps to keep contaminants from entering the system.

1. Lower the blade to the ground.
2. Release the system pressure. Refer to Operation and Maintenance Manual, "System Pressure - Release".

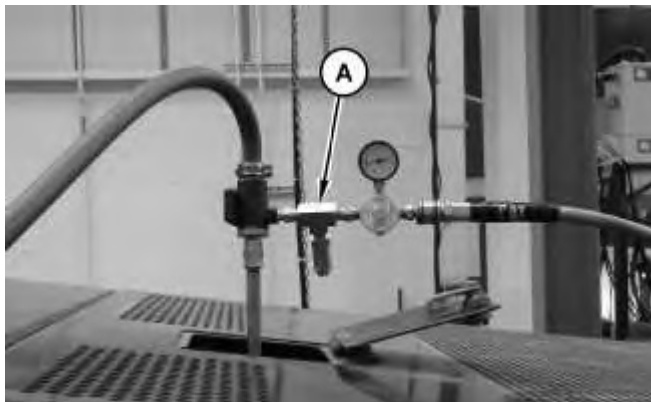

Illustration 1

g01368952

3. Install Tooling (A) onto the hydraulic tank. Attach an air supply hose onto Tooling (A). Apply 138 kPa (20 psi). This procedure will pull a vacuum on the hydraulic system.

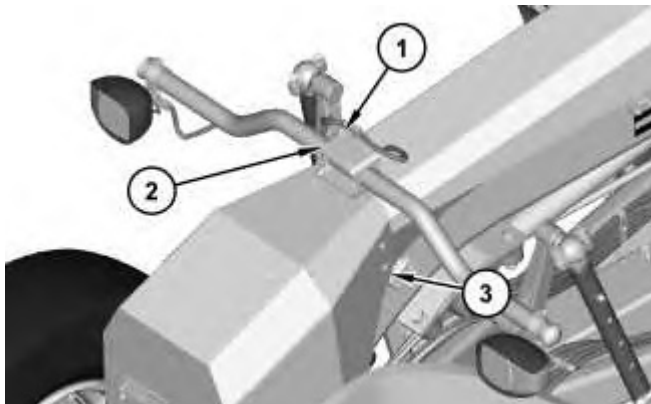

Illustration 2

g01430785

4. Loosen bolts (1). Remove bolts (2). Use two people in order to remove cover (3). The weight of cover (3) is approximately 32 kg (70 lb).
-

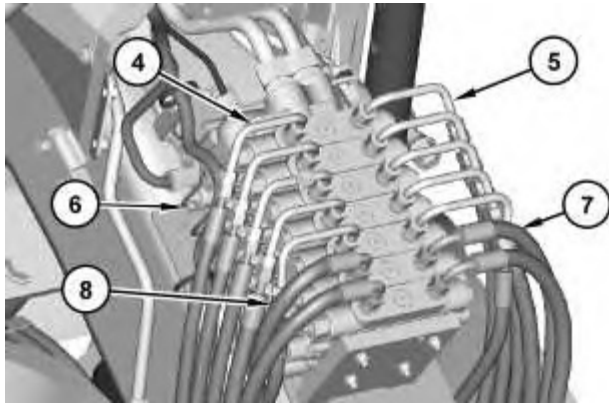

Illustration 3

g01430795

5. Disconnect tube assemblies (4) and tube assemblies (5).
6. Disconnect harness assembly (6). Repeat this step for the opposite side.
7. Disconnect hose assemblies (7) and hose assemblies (8).

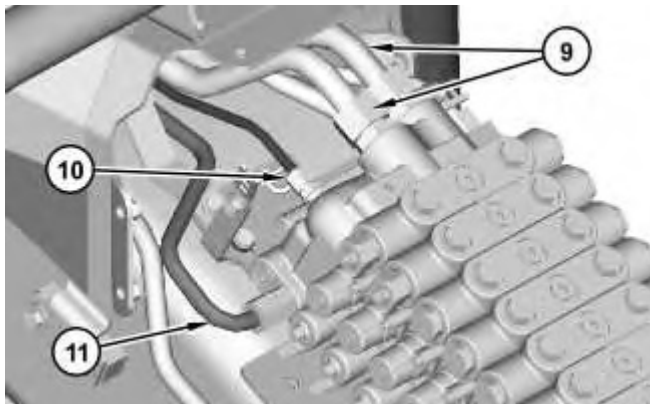

Illustration 4

g01430802

8. Disconnect tube assemblies (9). Disconnect tube assembly (10). Disconnect tube assembly (11).

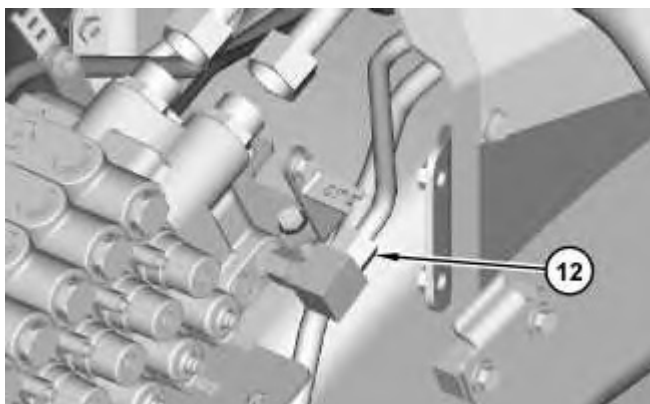

Illustration 5

g01430845

**Thank you very much
for your reading.**

**Please click here to buy
After you pay.**

**Then, you can
download the complete
manual instantly.
No waiting.**