

Product: MOTOR GRADER

Model: 140M 2 MOTOR GRADER R9M

Configuration: 140M Series 2 Motor Grader R9M00001-UP (MACHINE) POWERED BY C9 Engine

Disassembly and Assembly

12M Series 2, 140M Series 2 and 160M Series 2 Motor Graders Engine Supplement

Media Number -KENR8898-05

Publication Date -01/10/2018

Date Updated -30/10/2018

i05534526

Rear Gear Group - Remove and Install

SMCS - 1204-010; 1206-010

Removal Procedure

Table 1

Required Tools			
Tool	Part Number	Part Description	Qty
A	1P-0520	Driver Gp	1
B	1P-0510	Driver Gp	1

Start By:

- a. Remove the flywheel and pump drive gear.

NOTICE

Keep all parts clean from contaminants.

Contaminants may cause rapid wear and shortened component life.

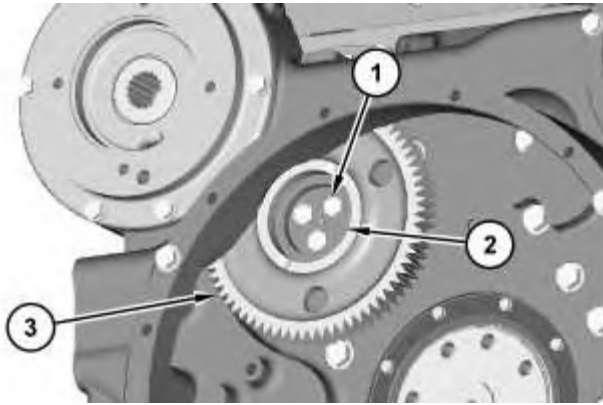

Illustration 1

g01386202

1. Remove bolts (1) and remove retainer (2). Remove gear assembly (3).



Illustration 2

g01383924

2. Use Tooling (A) in order to remove bushing (4) from gear assembly (3).

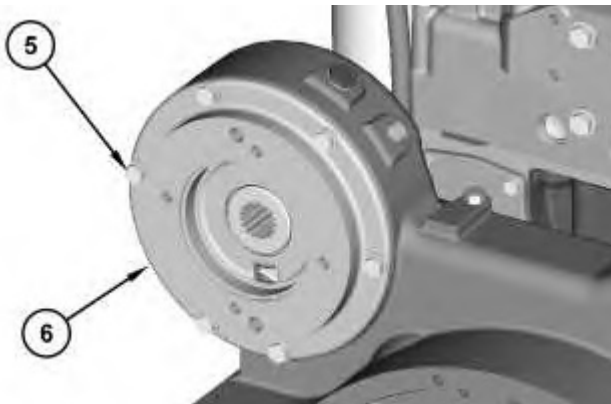

Illustration 3

g01386207

3. Remove bolts (5). Remove adapter (6) and the O-ring seal.

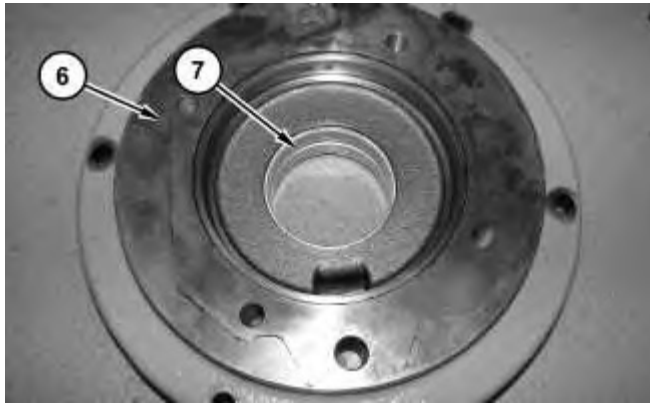

Illustration 4

g01384414

4. Use Tooling (B) in order to remove bearing (7) from adapter assembly (6).

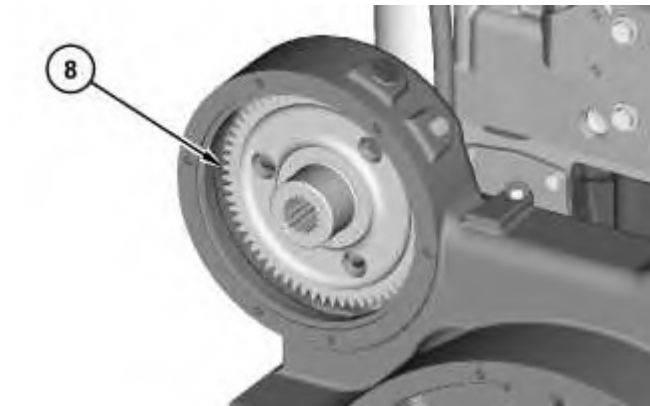

Illustration 5

g01386212

5. Remove gear assembly (8).

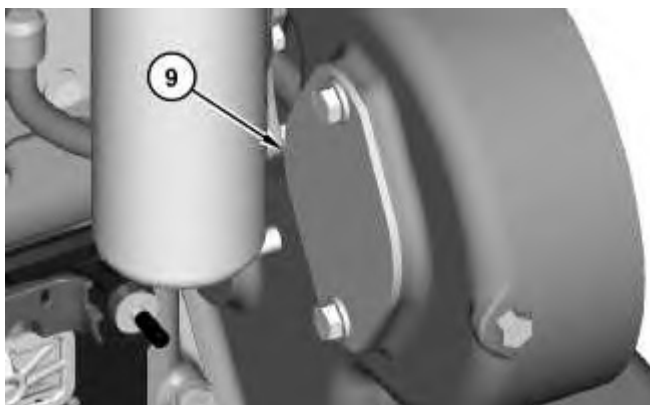

Illustration 6

g01386216

6. Remove cover (9) and the O-ring seal.
-

**Thank you very much
for your reading.**

**Please click here to buy
After you pay.**

**Then, you can
download the complete
manual instantly.
No waiting.**