

Product: EXCAVATOR

Model: 325 L EXCAVATOR 7CJ

Configuration: 325, 325L TRACK TYPE EXCAVATORS 7CJ00001-UP (MACHINE) POWERED BY 3116 ENGINE

## Disassembly and Assembly

**446 and 446B Backhoe Loaders, Lexion 450 Combine, 3114 and 3116 Engines, IT18F Integrated Toolcarrier, D6M Track-Type Tractor and 928F, 950F and 950G Wheel Loaders**

Media Number -SEN3611-18

Publication Date -01/05/2009

Date Updated -27/05/2009

i01943334

# Inlet and Exhaust Valves - Remove and Install

SMCS - 1105-010

## Removal Procedure

Table 1

Required Tools			
Tool	Part Number	Part Description	Qty
A	5S-1330	Valve Spring Compressor	1

### Start By:

- Remove the cylinder head assembly. Refer to Disassembly and Assembly, "Cylinder Head - Remove".

---

### NOTICE

**Keep all parts clean from contaminants.**

**Contaminants may cause rapid wear and shortened component life.**

---

**Note:** For information on the reusability of the inlet valves, the exhaust valves and the springs, refer to Guideline For Reusable Parts And Salvage Operations, SEBF8002, "Valves, Valve Springs, Valve Rotators, and Locks", Guideline For Reusable Parts And Salvage Operations, SEBF8034, "Valve and Valve Spring Specifications", and Guideline For Reusable Parts And Salvage Operations, SEBF8162, "Specifications to Measure and Salvage Cylinder Head Assemblies and Related Components".

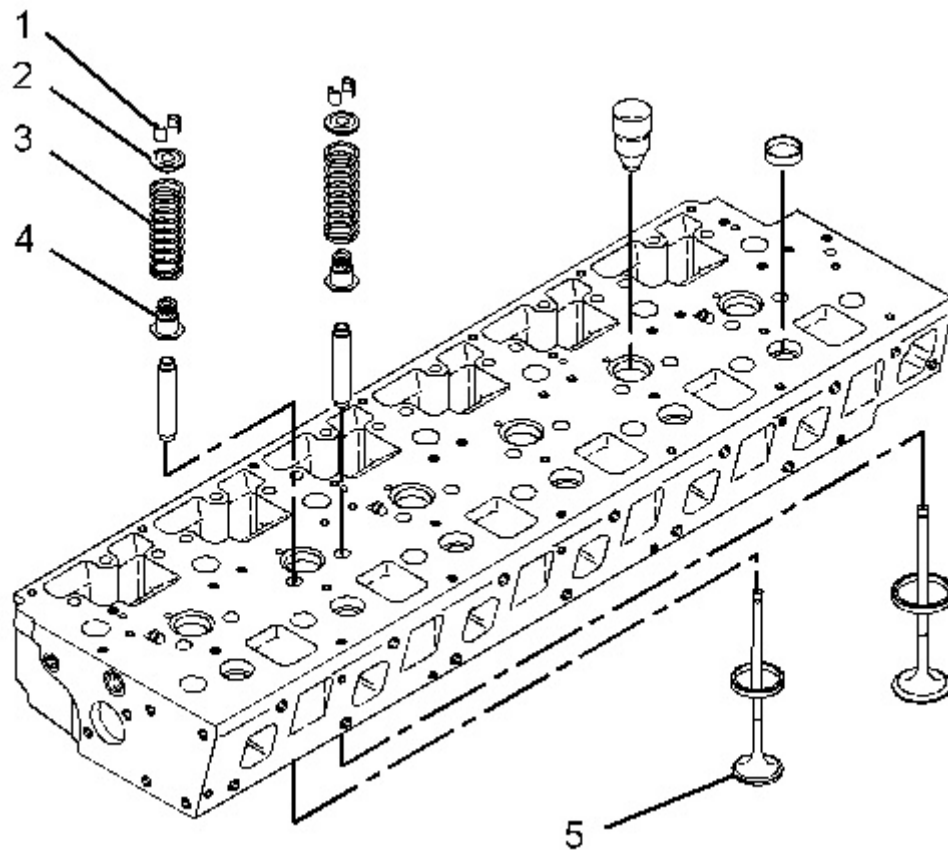

Illustration 1

g01011225

**Note:** The following components of the exhaust valves are different from the components of the inlet valves: spring retainer (2), valve spring (3) and valve (5).

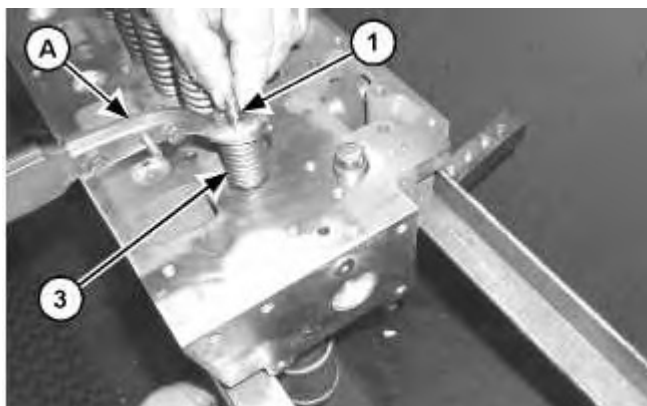

Illustration 2

g01011269

1. Use Tooling (A) to compress valve spring (3). Remove retainer lock (1).
2. Remove Tooling (A).
3. Remove spring retainer (2). Remove valve spring (3).

4. Remove valve seal (4) and valve (5).

5. Repeat Steps 1 through 4 in order to remove the remaining inlet valves and exhaust valves.

## Installation Procedure

Table 2

Required Tools			
Tool	Part Number	Part Description	Qty
A	5S-1330	Valve Spring Compressor	1

---

### NOTICE

**Keep all parts clean from contaminants.**

**Contaminants may cause rapid wear and shortened component life.**

---

**Note:** For information on the reusability of the inlet valves, the exhaust valves and the springs, refer to Guideline For Reusable Parts And Salvage Operations, SEBF8002, "Valves, Valve Springs, Valve Rotators, and Locks", Guideline For Reusable Parts And Salvage Operations, SEBF8034, "Valve and Valve Spring Specifications", and Guideline For Reusable Parts And Salvage Operations, SEBF8162, "Specifications to Measure and Salvage Cylinder Head Assemblies and Related Components".

---

**Thank you very much  
for your reading.**

**Please click here to buy  
After you pay.**

**Then, you can  
download the complete  
manual instantly.  
No waiting.**