

Product: BACKHOE LOADER

Model: 416B BACKHOE LOADER 8SG

Configuration: 416B Backhoe Loader 8SG12000-14798 (MACHINE) POWERED BY 3054 Engine

## **Disassembly and Assembly 3054 Engine for Caterpillar Built Machines**

Media Number -SEN6241-13

Publication Date -01/08/2008

Date Updated -04/08/2008

i01741403

# **Crankshaft Rear Seal - Remove**

SMCS - 1161-011

## **Removal Procedure**

### **Start By:**

- a. Remove the flywheel. Refer to Disassembly and Assembly, "Flywheel - Remove".

---

### **NOTICE**

**Keep all parts clean from contaminants.**

**Contaminants may cause rapid wear and shortened component life.**

---

---

### **NOTICE**

**Care must be taken to ensure that fluids are contained during performance of inspection, maintenance, testing, adjusting and repair of the product. Be prepared to collect the fluid with suitable containers before opening any compartment or disassembling any component containing fluids.**

**Refer to Special Publication, NENG2500, "Caterpillar Dealer Service Tool Catalog" for tools and supplies suitable to collect and contain fluids on Caterpillar products.**

**Dispose of all fluids according to local regulations and mandates.**

---

## Engines with 14 Bolt Housing Assembly

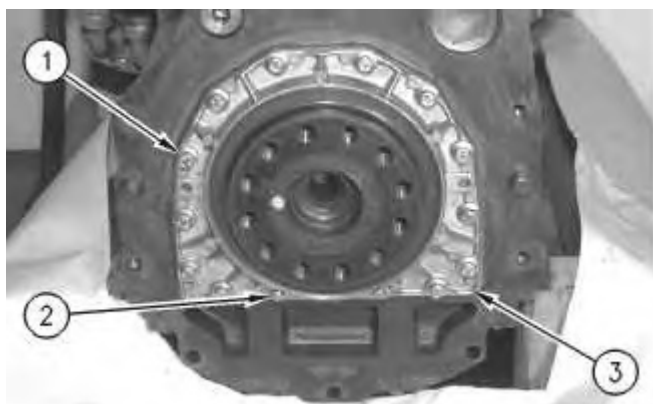

Illustration 1

g00632744

The flywheel housing has been removed for photographic purposes only.

1. Remove bolts (1) from housing (3).
2. Remove socket head bolts (2) from housing (3).
3. Remove the crankshaft rear seal, the gasket, and housing (3) from the dowels in the cylinder block.

## Engines with 10 Bolt Housing Assembly

**Note:** The 10 bolt housing assembly is manufactured as a one-piece assembly. The 10 bolt housing assembly is NOT adaptable to engines that have the 14 bolt housing assembly.

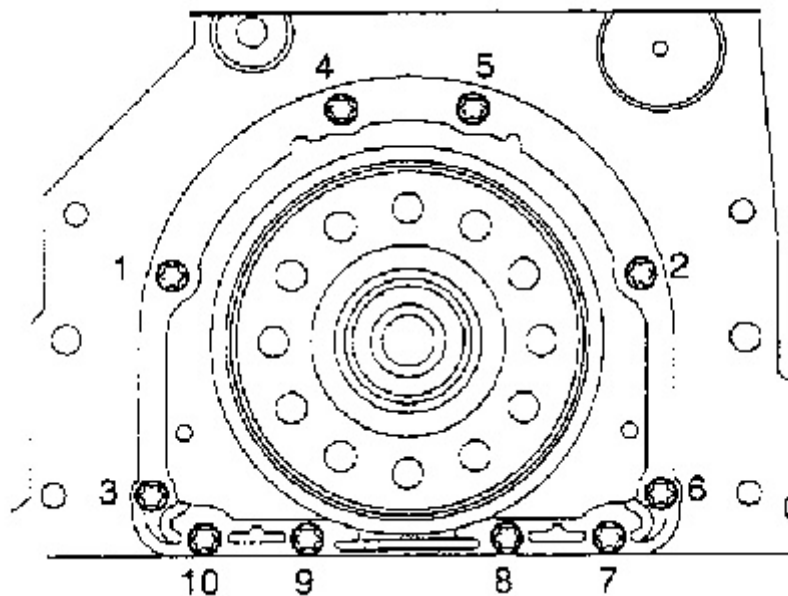

Illustration 2

g00830867

1. Remove the bolts in reverse order of the numbered sequence. Refer to Illustration 2.
  2. Remove the one-piece housing assembly from the cylinder block.
-

**Thank you very much  
for your reading.**

**Please click here to buy  
After you pay.**

**Then, you can  
download the complete  
manual instantly.  
No waiting.**