

Product: COMPACT TRACK LOADER

Model: 239D COMPACT TRACK LOADER CD4

Configuration: 239D Compact Track Loader CD400001-UP (MACHINE) POWERED BY C2.2 Engine

Disassembly and Assembly

C1.1, C1.5 and C2.2 Engines for Caterpillar Built Machines

Media Number -KENR6948-06

Publication Date -01/06/2015

Date Updated -02/08/2018

i07360664

Fuel Injection Pump - Remove and Install

SMCS - 1251-010

Removal Procedure

Start By:

- a. Remove the fuel shutoff solenoid. Refer to Disassembly and Assembly, "Fuel Shutoff Solenoid - Remove and Install".

NOTICE

Care must be taken to ensure that fluids are contained during performance of inspection, maintenance, testing, adjusting and repair of the product. Be prepared to collect the fluid with suitable containers before opening any compartment or disassembling any component containing fluids.

Dispose of all fluids according to local regulations and mandates.

NOTICE

Keep all parts clean from contaminants.

Contaminants may cause rapid wear and shortened component life.

Note: The removal procedure is similar for the three cylinder and the four cylinder engines. The Illustrations show a four cylinder engine.

1. Remove the fuel injection lines. Refer to Disassembly and Assembly, "Fuel Injection Lines - Remove and Install" for more information.

The C1.1 engine has a flexible fuel return hose.

For engines with a flexible fuel return hose, disconnect the fuel hose from the inlet connection of the fuel injection pump.

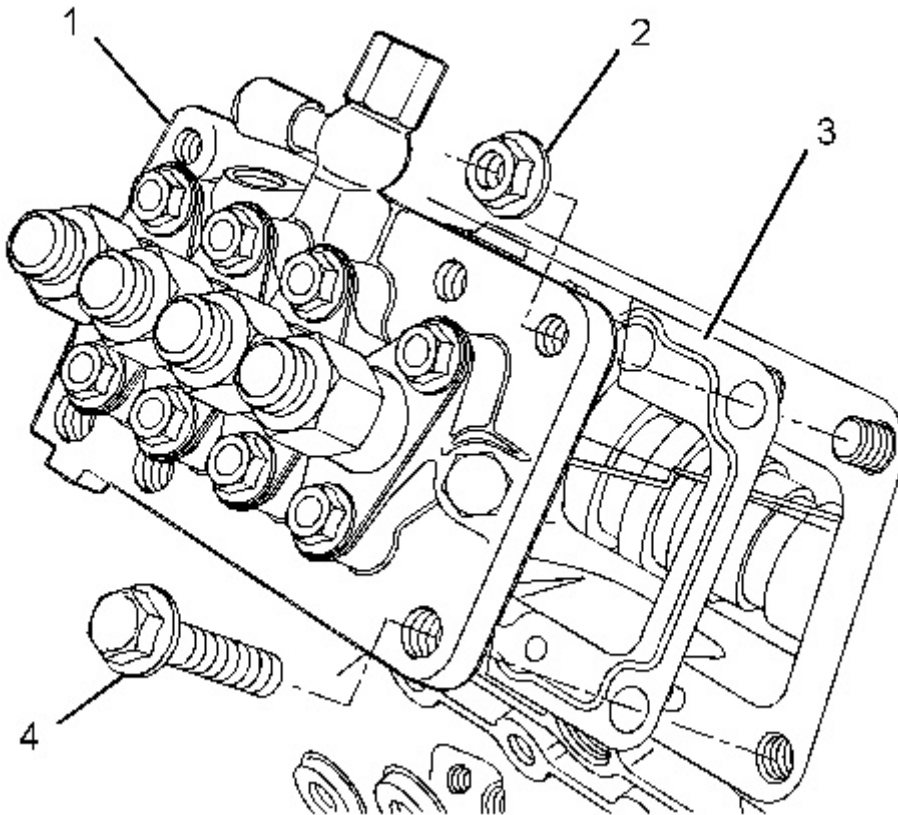

Illustration 1
Typical example

g01327005

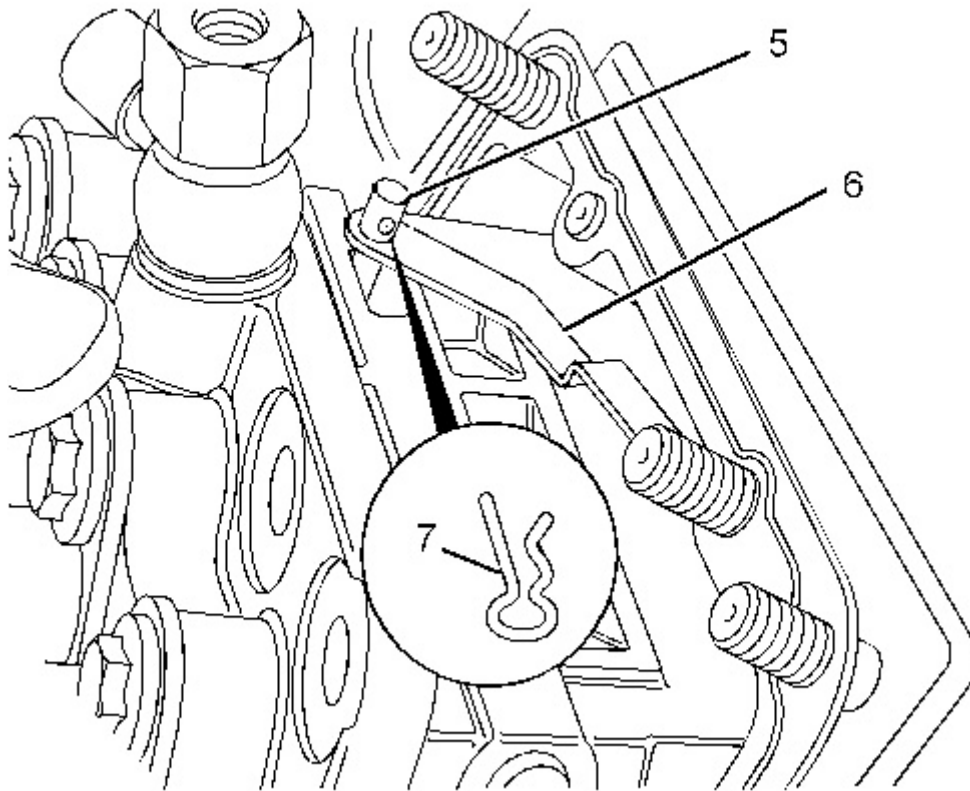

Illustration 2
Typical example

g01327006

2. Gradually loosen bolts (4) and nuts (2) that fasten the fuel injection pump to the cylinder block.
3. Carefully raise fuel injection pump (1) from the cylinder block and remove clip (7) that connects link (6) to fuel rack control (5).
4. Remove fuel injection pump (1) from the cylinder block.
5. Remove shims (3) from the mounting face of the cylinder block.

Note: Record the thickness of each shim and the number of shims for reassembly. The fuel injection timing is determined by the thickness of the shim pack that is between the fuel injection pump and the mounting face on the cylinder block. Refer to Systems Operation, Testing and Adjusting, "Fuel Injection Timing - Check" for more information.

Installation Procedure

NOTICE

Keep all parts clean from contaminants.

Contaminants may cause rapid wear and shortened component life.

**Thank you very much
for your reading.**

**Please click here to buy
After you pay.**

**Then, you can
download the complete
manual instantly.
No waiting.**