

Model: 140K MOTOR GRADER JPA

Configuration: 140K Motor Grader JPA00001-UP (MACHINE) POWERED BY C7 Engine

Disassembly and Assembly 12K, 140K and 160K Motor Graders Power Train

Media Number -KENR8443-04

Publication Date -01/03/2017

Date Updated -28/03/2017

i02186165

Final Drive - Disassemble

SMCS - 4050-015

Disassembly Procedure

Table 1

Required Tools			
Tool	Part Number	Part Description	Qty
A	439-3938	Link Brackets	2
B	5P-4204	Wrench Assembly	1

Start By:

- Remove the final drives. Refer to Disassembly and Assembly, "Final Drive - Remove" for the correct procedure.

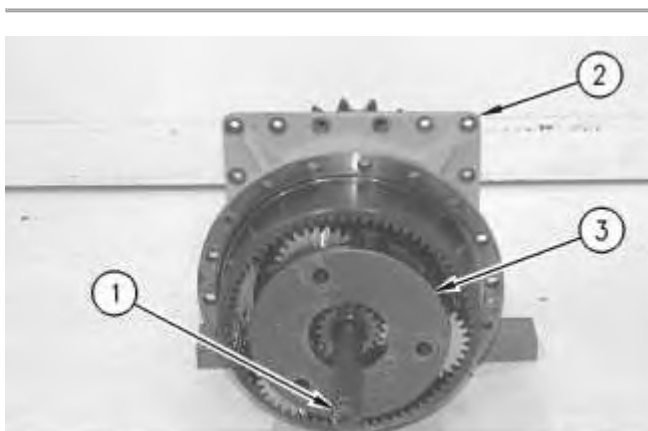

Illustration 1

g00621106

1. Remove sun gear shaft (1) from housing (2).
2. Remove planetary carrier (3) from housing (2).

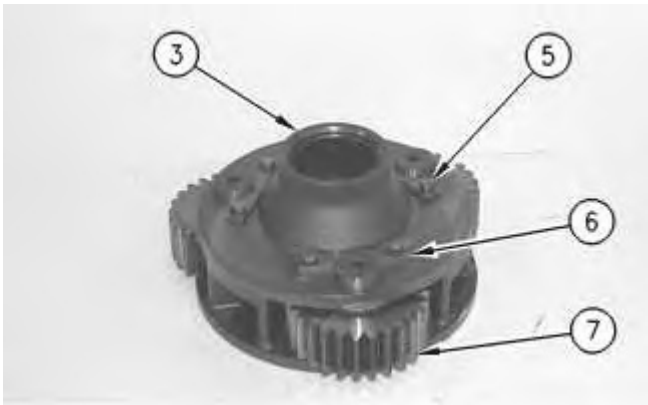

Illustration 2

g00621108

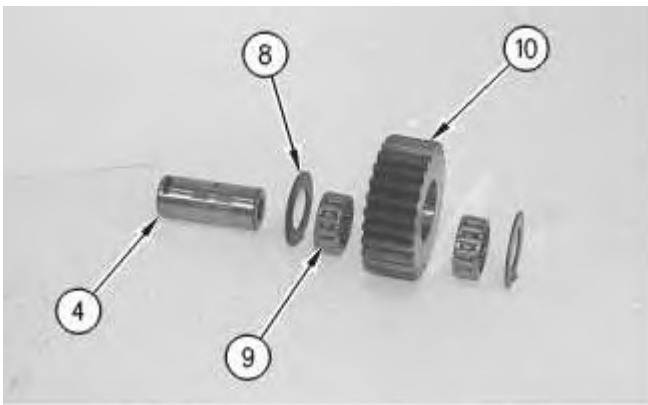

Illustration 3

g00621109

3. Remove locking bolts (5), the washers, and retainers (6) from planetary carrier (3).
4. Remove planetary shafts (4) to remove gear assemblies (7) from planetary carrier (3).

Note: Each gear assembly (7) consists of two washers (8), two roller assemblies (9), gear (10) and planetary shaft (4).

Note: Mark the location of the components of the gear assemblies for assembly purposes.

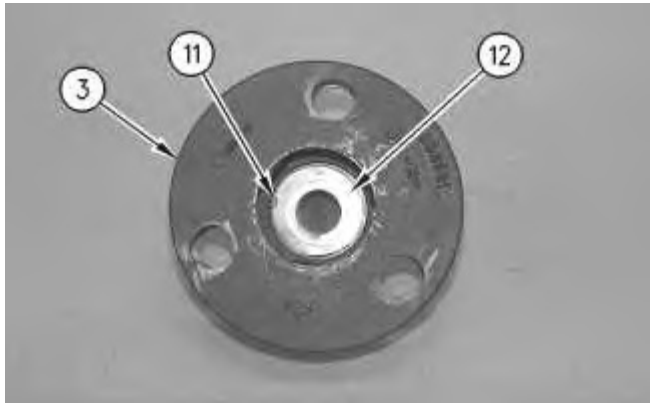

Illustration 4

g00621111

5. Remove retaining ring (11) and washer (12) from planetary carrier (3).

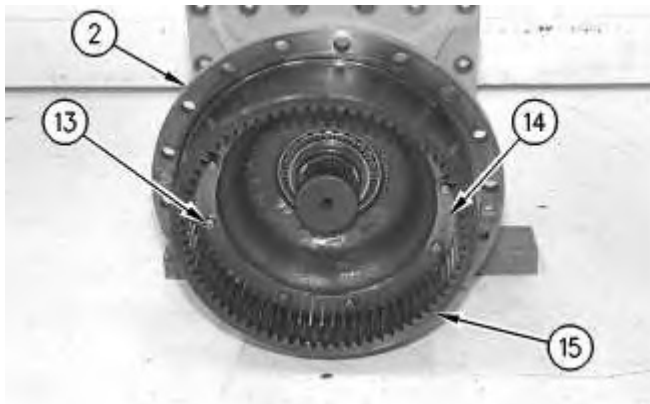

Illustration 5

g00621112

6. Remove locking bolts (13), the washers, and plates (14) to remove ring gear (15).
7. Remove ring gear (15) from the housing (2).

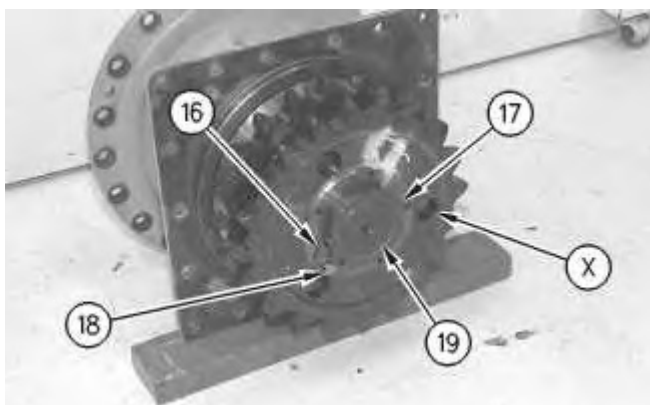

Illustration 6

g00621113

8. Remove locking bolt (18), the washer, and lock (16) which holds nut (17) to drive shaft (19).

**Thank you very much
for your reading.**

**Please click here to buy
After you pay.**

**Then, you can
download the complete
manual instantly.
No waiting.**