

Illustration 7

g01191992

9. Remove bolt (11) and washer (12) to remove shaft yoke (13). Remove the O-ring seal from bearing carrier (4) and hitch drive shaft (14).

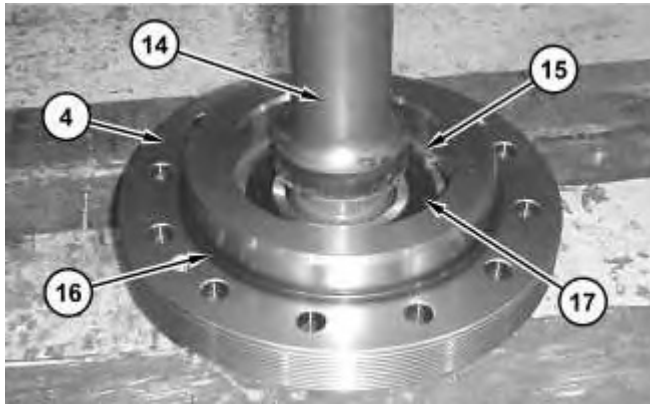

Illustration 8

g01191995

10. Use Tooling (D) to remove retaining ring (15) from bearing carrier (4).
11. Remove hitch drive shaft (14) and roller bearing (17) from the bearing carrier as a unit. Remove O-ring seal (16) from the bearing carrier.

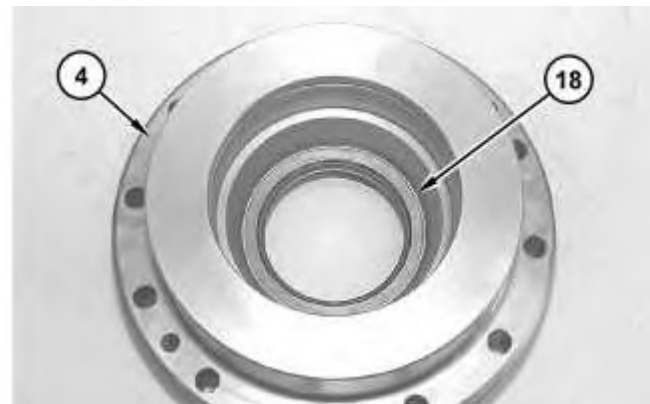

Illustration 9

g01191999

12. Use a suitable punch to remove lip seal (18) from bearing carrier (4).

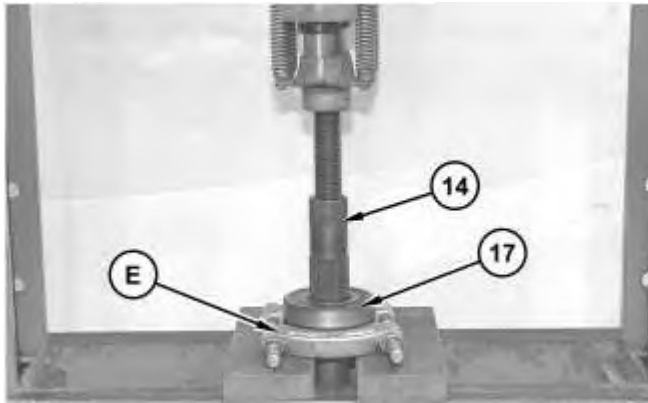

Illustration 10

g01192003

13. Use a suitable press and Tooling (E) to remove bearing (17) from hitch drive shaft (14). Invert the hitch drive shaft and remove the bearing (not shown) from the other side of hitch drive shaft (14).



Illustration 11

g00837532

14. Remove bolts (19) and the washers to disconnect bearing carrier (8) from the hitch tube. Install Tooling (F) into the threaded holes in the bearing carrier to force the bearing carrier from the hitch tube. Remove the bearing carrier from the machine. Remove Tooling (F).



15. Remove bearing assembly (20) from bearing carrier (8). Remove O-ring seal (21).



Illustration 13

16. Use a suitable punch to remove lip seal (22) from bearing carrier (8).

Installation Procedure

Table 2

Required Tooling			
Tool	Part Number	Part Description	Qty
A	236-1192	Lift Cylinder Brace	3
G	1P-0520	Driver Group	1
C	138-7573	Link Bracket	1
D	136-1452	Internal Tip Pliers	1
H	5P-0960	Grease Cartridge Molybdenum Grease	1
J	5P-3931	Anti-Seize Compound	1

1. Inspect all parts and clean all parts. If any parts are worn or damaged, use new Caterpillar parts for replacement.

**Thank you very much
for your reading.**

**Please click here to buy
After you pay.**

**Then, you can
download the complete
manual instantly.
No waiting.**