

Product: BACKHOE LOADER

Model: 416E BACKHOE LOADER LMS

Configuration: 416E Backhoe Loader Single Tilt LMS00001-UP (MACHINE) POWERED BY C4.4 Engine

Disassembly and Assembly 3054C Engines for Caterpillar Built Machines

Media Number -SEN5069-18

Publication Date -01/05/2015

Date Updated -19/09/2018

i02293676

Crankshaft Rear Seal - Install

SMCS - 1161-012

Installation Procedure

Table 1

Required Tools			
Tool	Part Number	Part Description	Qty
A	FT-2806	Alignment Tool	1

Note: The crankshaft rear seal and the housing for the crankshaft rear seal are manufactured as a one-piece assembly. The assembly of the crankshaft rear seal uses ten setscrews in order to fasten the assembly to the cylinder block.

Note: The following procedure assumes that the crankshaft rear seal is a replacement assembly.

Note: The crankshaft rear seal is lubricated. There is no need to lubricate the seal or the crankshaft flange before installation.

Note: An installation sleeve (2) is supplied with the new housing assembly. The installation sleeve must be in place when housing assembly is installed on the crankshaft flange in order to prevent damage to the crankshaft rear seal during assembly.

NOTICE

Keep all parts clean from contaminants.

Contaminants may cause rapid wear and shortened component life.

1. Ensure that the crankshaft flange (1) is clean, dry and free from rough metal edges. Ensure that the face of the cylinder block and the bridge in the crankcase are clean and dry.

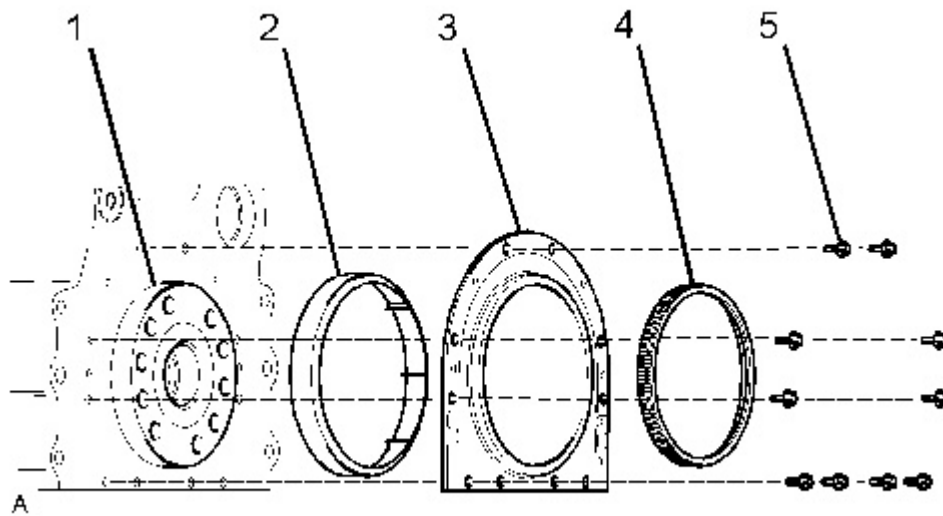

Illustration 1

g01148393

2. Remove the packaging from the new assembly of the crankshaft rear seal (3). Ensure that the plastic sleeve (2) is squarely installed within the seal of the assembly of the crankshaft rear seal (3). The plastic sleeve (2) is included in order to protect the lip of the seal as the lip is pushed over the crankshaft flange (1).

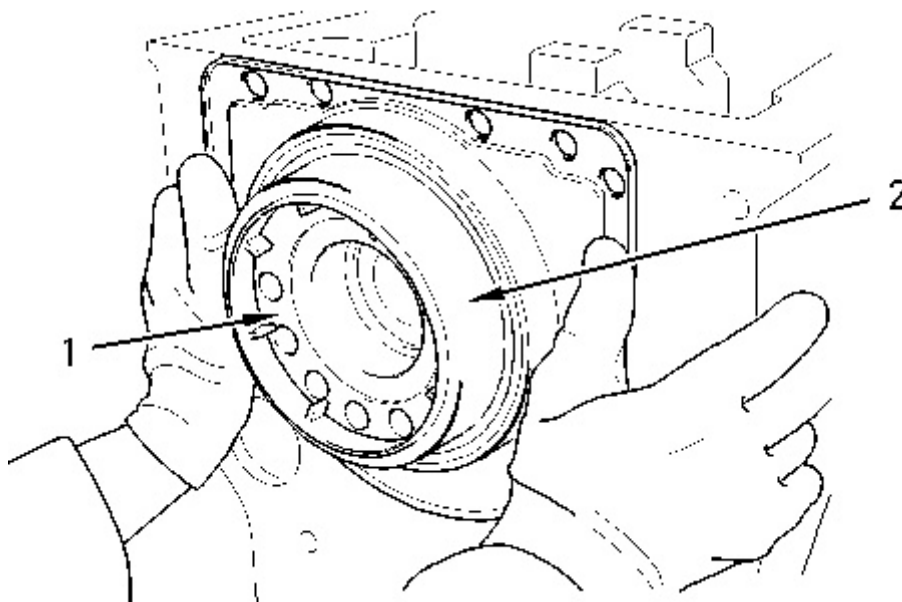

Illustration 2

g01004958

Typical example

3. Place the assembly of the crankshaft rear seal (3) over the crankshaft flange (1) and engage the plastic sleeve (2) onto the crankshaft flange.

4. Ensure that the plastic sleeve (2) is engaged onto the crankshaft flange (1). Push the assembly of the crankshaft rear seal (3) evenly and push the assembly smoothly onto the crankshaft flange (1) until the assembly is against the cylinder block. During this process, the plastic sleeve (2) will be forced out of the assembly of the crankshaft rear seal (3). Discard the plastic sleeve (2).
5. Rotate the assembly of the crankshaft rear seal (3) in order to align the setscrew holes in the assembly with the setscrew holes in the rear face of the cylinder block.
6. Install the setscrews (5) in order to position housing assembly (3) to the cylinder block. Do Not tighten the bolts.
7. Place the Tooling (A) over housing assembly (2). This will center the housing assembly onto the crankshaft flange (3).

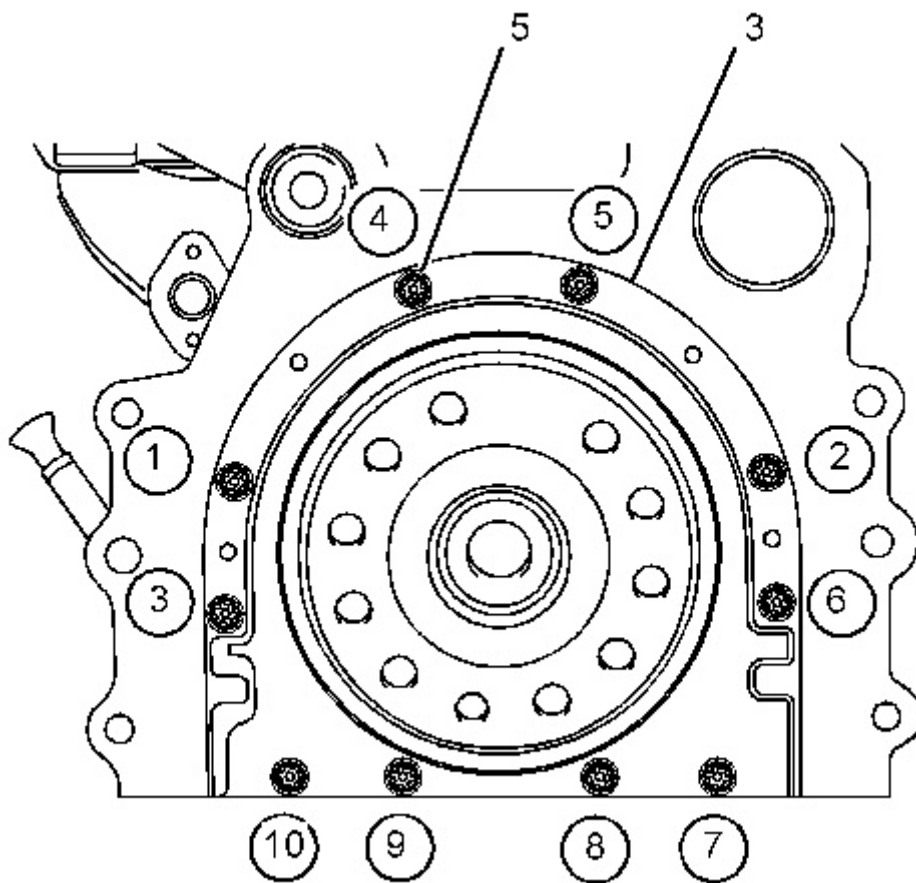

Illustration 3

g01148495

8. Tighten the setscrews (1) in numerical order to a torque of 22 N·m (16 lb ft). Do not tighten the setscrews (X) at this time.
9. Remove the Tooling (A). Tighten the setscrews (X) to a torque of 22 N·m (16 lb ft).

End By:

- a. Install the flywheel. Refer to Disassembly and Assembly, "Flywheel - Install".
-

**Thank you very much
for your reading.**

**Please click here to buy
After you pay.**

**Then, you can
download the complete
manual instantly.
No waiting.**