

---

## NOTICE

**Keep all parts clean from contaminants.**

**Contaminants may cause rapid wear and shortened component life.**

---

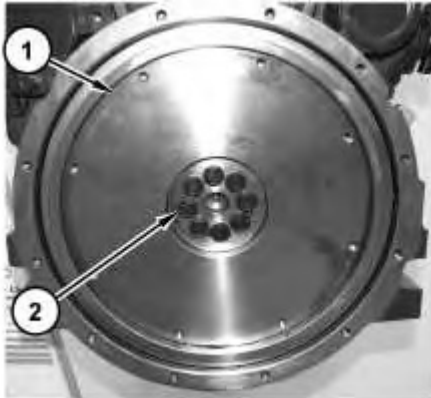

---

Illustration 1

g02794543

1. Remove two bolts (2) from flywheel (1).
- 

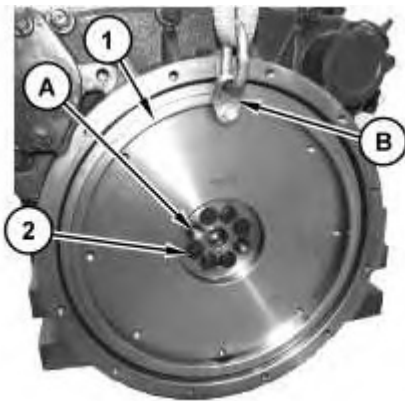

---

Illustration 2

g02798921

2. Install Tooling (A) into the crankshaft.
  3. Install Tooling (B) and a suitable lifting device on flywheel (1). The weight of flywheel (1) is approximately 30 kg (66 lb).
  4. Remove remaining bolts (2).
  5. Remove flywheel (1) from the cylinder block.
-



Illustration 3

g02798923

6. Inspect flywheel (1) and the ring gear (3) for wear and damage. Replace any worn components or damaged components.
7. If necessary, remove the flywheel ring gear (3), follow Step 7.a through Step 7.b.
  - a. Place the flywheel assembly on a suitable support.
  - b. Use a hammer and a punch in order to remove ring gear (3) from flywheel (1). If necessary, a torch may be needed to heat ring gear (3).

**Note:** Identify the orientation of the teeth on the flywheel ring gear (3).

## Installation Procedure

Table 2

Required Tools			
Tool	Part Number	Part Description	Qty
A	-	Guide Stud M12 - 1.25 by 100 mm	2
B	138-7573	Link Bracket	1

---

### NOTICE

**Keep all parts clean from contaminants.**

**Contaminants may cause rapid wear and shortened component life.**

---



Illustration 4

g02798923



**WARNING**

**Always wear protective gloves when handling parts that have been heated.**

1. If flywheel ring gear (3) was removed, follow Step 1.a through Step 1.c in order to install ring gear (3) to flywheel (1).

a. Identify the orientation of teeth on new ring gear (3).

**Note:** The chamfered side of ring gear teeth must face toward the starting motor when the flywheel is installed. This position will ensure the correct engagement of the starting motor.

b. Raise heat of flywheel ring gear (3) in an oven to a maximum temperature of 250 °C (482 °F) prior to installation.

**Note:** Do not use a torch to heat the ring gear.

c. Ensure that the orientation of ring gear (3) is correct and quickly install the ring gear onto flywheel (1).



**Thank you very much  
for your reading.**

**Please click here to buy  
After you pay.**

**Then, you can  
download the complete  
manual instantly.  
No waiting.**