

Product: SKID STEER LOADER

Model: 246D SKID STEER LOADER JSL

Configuration: 246D Skid Steer Loader JSL00001-UP (MACHINE) POWERED BY C3.3B Engine

## Disassembly and Assembly C2.6 and C3.3B Engines for Caterpillar Built Machines

Media Number -UENR0137-11

Publication Date -01/08/2015

Date Updated -12/07/2018

i05242551

# Flywheel Housing - Remove and Install

SMCS - 1157-010

## Removal Procedure

Table 1

Required Tools			
Tool	Part Number	Part Description	Qty
A	-	Guide Stud M12 x 1.25 by 100 mm	2
B	138-7575	Link Brackets	2

### Start By:

- a. Remove the flywheel.
- b. Remove the rear crankshaft seal.

**Note:** Refer to Specification UENR0995 "Engine Design" for non-specified engine Torque Values.

---

### NOTICE

**Keep all parts clean from contaminants.**

**Contaminants may cause rapid wear and shortened component life.**

---

---

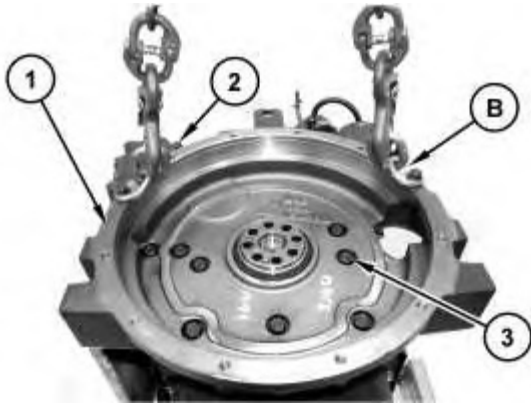

---

Illustration 1

g02794824

1. Remove two bolts (3) from flywheel housing (1).
2. Install Tooling (A) into flywheel housing (1).
3. Install Tooling (B). Install a suitable lifting device to flywheel housing (1). The weight of flywheel housing (1) is approximately 25 kg (55 lb).
4. Remove remaining six bolts (3) and 8 bolts (2) from flywheel housing (1).
5. Remove flywheel housing (1) from the cylinder block.



---

Illustration 2

g02794825

6. Remove bearing (4).
7. Remove the gasket (5).
8. If necessary, remove the dowels from the cylinder block.

## Installation Procedure

1. Install flywheel housing (1) in the reverse order of removal.
-

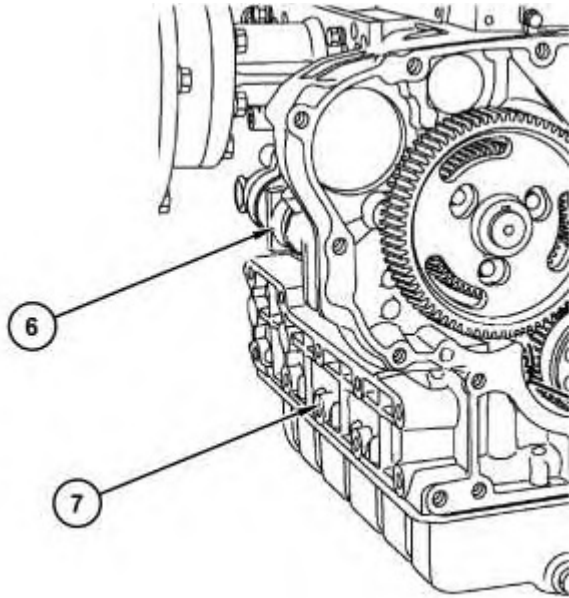

---

Illustration 3

g02863884

- a. Install liquid gasket to the seam between the lower crankcase section (7) and the upper crankcase section (6).
  - b. For the C3.3B tighten 8 bolts (3) and 8 bolts (2) to a torque of 103 to 117 N·m (76 to 87 lb ft).
  - c. For the C2.6 tighten 8 bolts (3) and 8 bolts (2) to a torque of 78 to 90 N·m (58 to 66 lb ft).
-

**Thank you very much  
for your reading.**

**Please click here to buy  
After you pay.**

**Then, you can  
download the complete  
manual instantly.  
No waiting.**