

Product: EJECTOR TRUCK

Model: 740B EJECTOR TRUCK L4F

Configuration: 740B Ejector Articulated Truck L4F00001-UP (MACHINE) POWERED BY C15 Engine

Disassembly and Assembly C15 and C18 Engines for Caterpillar Built Machines

Media Number -REN8261-28

Publication Date -01/08/2015

Date Updated -28/08/2018

i05025929

Flywheel Housing - Remove and Install - Equipped with Rear Power Take-Off

SMCS - 1157-010

Removal Procedure

Table 1

Required Tools			
Tool	Part Number	Part Description	Qty
A	138-7574	Link Bracket	2

Start By:

- Remove the crankshaft rear seal. Refer to Disassembly and Assembly, "Crankshaft Rear Seal - Remove".
- Remove the electric starting motor. Refer to Disassembly and Assembly, "Electric Starting Motor - Remove".
- Remove the rear power take-off (RPTO). Refer to Disassembly and Assembly, "Rear Power Take-Off (RPTO) - Remove".

NOTICE

Keep all parts clean from contaminants.

Contaminants may cause rapid wear and shortened component life.

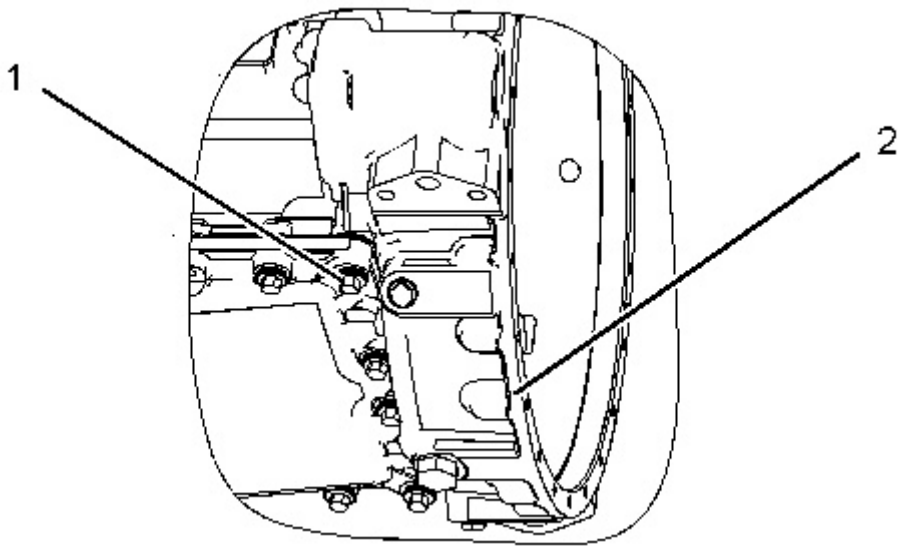

Illustration 1

g01008304

1. Remove bolts (1) that fasten the engine oil pan to flywheel housing (2).

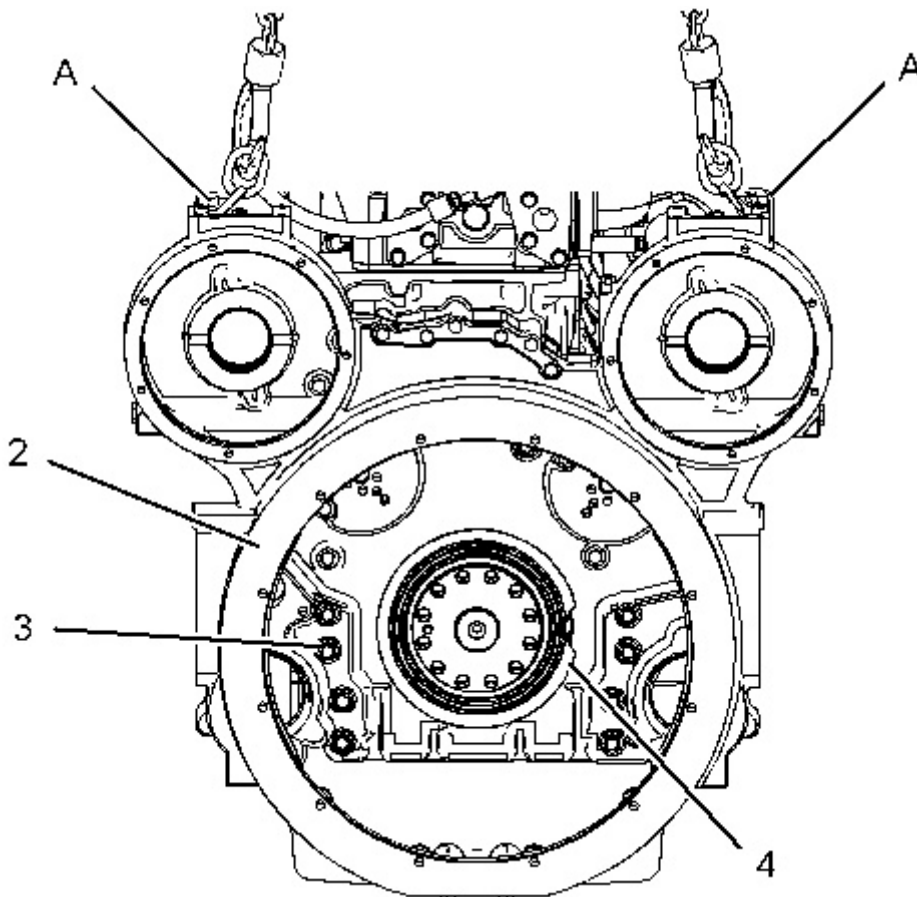

Illustration 2

g01050505

2. Install Tooling (A) and a suitable lifting device on flywheel housing (2). The weight of flywheel housing (2) is approximately 134 kg (295 lb).

3. Remove bolts (3). Remove flywheel housing (2) and the gasket from the cylinder block.

4. Remove baffle (4) from the flywheel housing.

Installation Procedure

Table 2

Required Tools			
Tool	Part Number	Part Description	Qty
A	138-7574	Link Bracket	2
B	-	Loctite 5900	-

NOTICE

Keep all parts clean from contaminants.

Contaminants may cause rapid wear and shortened component life.

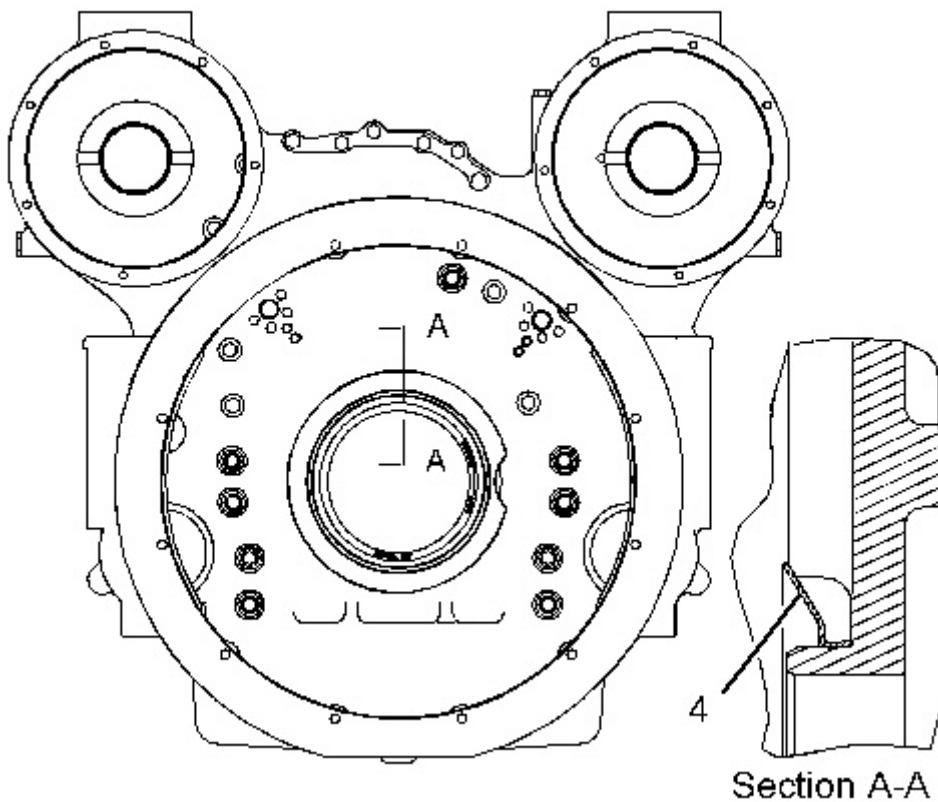

**Thank you very much
for your reading.**

**Please click here to buy
After you pay.**

**Then, you can
download the complete
manual instantly.
No waiting.**