

Product: EXCAVATOR

Model: 245 EXCAVATOR 94L

Configuration: 245 EXCAVATOR 94L00255-UP (MACHINE) POWERED BY 3406 ENGINE

Disassembly and Assembly Starting Motor - Delco 50-MT

Media Number -SEN3860-03

Publication Date -01/03/2007

Date Updated -06/07/2016

i02711568

Starting Motor - Assemble

SMCS - 1453-016

Assemble the Starting Motor

Note: The following procedure is only for the 24 volt starting motor.

Table 1

Tools Needed
1P-0510 Driver Gp
1P-1855 Retaining Ring Pliers

1. Lubricate the following items with SAE 20W oil: bushings, seals and oil wicks.



Illustration 1

g00705427

2. Put the field winding assembly (35) and pole shoes (34) in position in the starting motor housing. Install the twelve screws (37) and tighten to a torque of $20.3 \pm 2.3 \text{ N}\cdot\text{m}$ ($180 \pm 20 \text{ lb in}$). Install the motor terminal (36), the washers and the nut. Tighten the nut to a torque of $30 \pm 3 \text{ N}\cdot\text{m}$ ($22 \pm 2.0 \text{ lb ft}$).

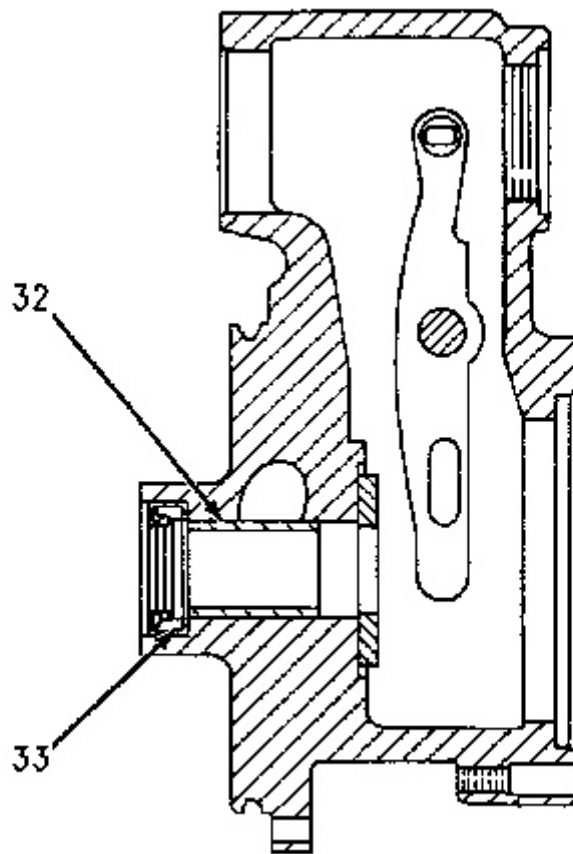

Illustration 2

g00705400

3. Use a **1P-0510** Driver Gp to install the bushing (32) and the seal (33) into the shift lever housing .

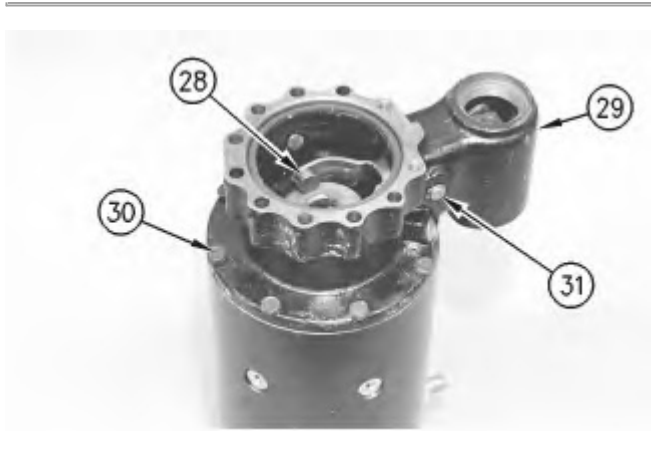

Illustration 3

g00705073

4. Install the seals on the shaft (31). Position the shift lever assembly (28) into the shift lever housing. Use a **1P-1855** Retaining Ring Pliers to install the shaft (31) and the snap ring .
5. Install the O-ring seal and the gasket onto the shift lever housing. Set the shift lever housing assembly (29) onto the starting motor housing in the correct position. Install the seven bolts and tighten the bolts (30) to a torque of 12.2 ± 2.7 N·m (108 ± 24 lb in).



Illustration 4

g00704879

6. Use **5P-0960** Molybdenum Grease to lubricate the armature assembly bushing areas. Do not grease the armature core or the commutator.
7. Put the pinion drive assembly (27) into position in the fork of the shift lever. Put the spacer on the armature assembly (26). Install the armature assembly (26) into the starting motor housing and the shift lever housing. Slide the armature assembly (26) into the pinion drive assembly (27).

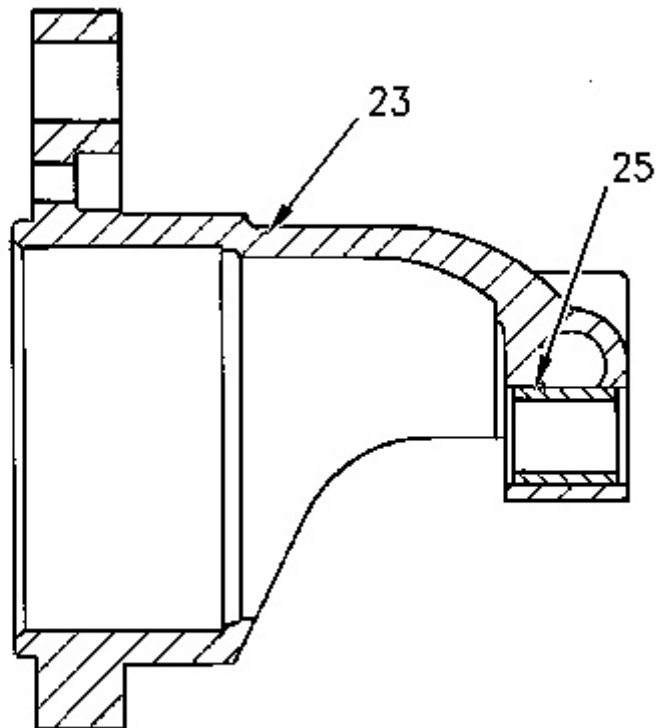

Illustration 5

g00704875

8. Use a **1P-0510** Driver Gp to install the bushing (25) into the pinion drive housing (23).

**Thank you very much
for your reading.**

**Please click here to buy
After you pay.**

**Then, you can
download the complete
manual instantly.
No waiting.**