

Product: TRACK-TYPE TRACTOR

Model: D8L TRACK-TYPE TRACTOR 7YB

Configuration: D8L TRACTOR 7YB01573-UP (MACHINE) POWERED BY 3408 ENGINE

## Disassembly and Assembly 3408E and 3412E Engines for Caterpillar Built Machines

Media Number -REN2336-06

Publication Date -01/08/2018

Date Updated -10/08/2018

i03335401

# Gear Group (Rear) - Remove

SMCS - 1206-011; 1212-011

## Removal Procedure

Table 1

Required Tools			
Tool	Part Number	Part Description	Qty
A	1P-0483 <sup>(1)</sup>	Drive Plate	1
	1U-5839	Bearing Puller	1
B	FT-1342	Guide Bolt	2

<sup>(1)</sup> Part of the **1P-0510** Driver Group

### Start By:

- a. Remove the flywheel housing. Refer to Disassembly and Assembly, "Flywheel Housing - Remove and Install".

---

### NOTICE

**Keep all parts clean from contaminants.**

**Contaminants may cause rapid wear and shortened component life.**

---

**Note:** There are many possible configurations of the rear gear group and flywheel housing. The following procedure illustrates a typical example.

1. Use the following procedure for disassembly of the adapter assemblies.

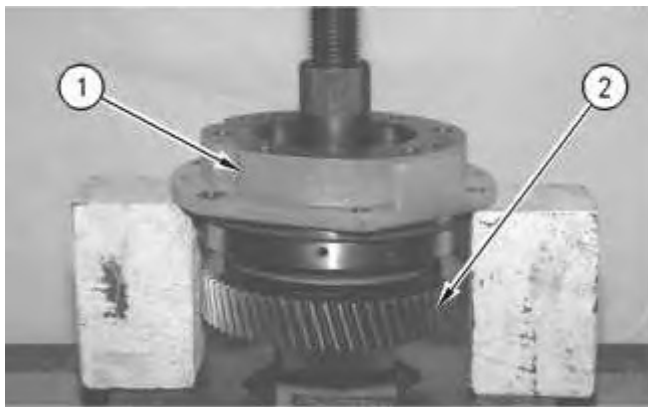

Illustration 1

g00586481

Typical example

- a. Support adapter assembly (1) so that the gear assembly can be pressed out of the adapter assembly. Press gear assembly (2) out of the adapter assembly.



Illustration 2

g00586630

Typical example

- b. Use Tooling (A) in order to remove bearing (3) from the gear assembly.



Illustration 3

g00586904

Typical example

c. Use a press in order to remove bearing (4) from adapter assembly (1).



Illustration 4

g00586907

Typical example

d. Remove bolts (5) and ring (6) from adapter assembly (1).

e. Remove O-ring seal (7) from adapter assembly (1).

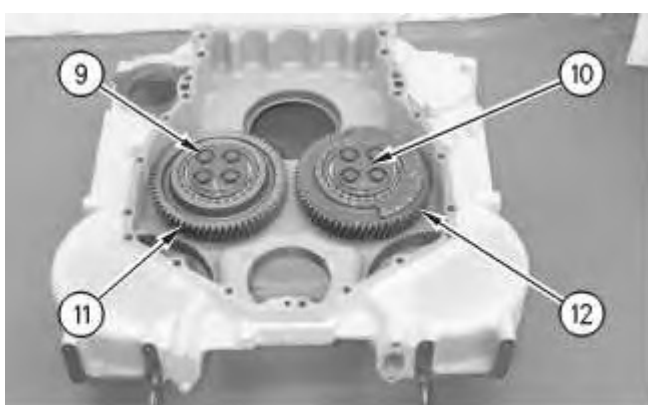

Illustration 5

g00586910

Typical example

f. If necessary, remove race (8) from adapter assembly (1).



**Thank you very much  
for your reading.**

**Please click here to buy  
After you pay.**

**Then, you can  
download the complete  
manual instantly.**

**No waiting.**