

Product: EXCAVATOR

Model: 320D EXCAVATOR GKS

Configuration: 320D Log Loader GKS00001-UP (MACHINE) POWERED BY C6.4 Engine

Disassembly and Assembly C6.4 Engine for Caterpillar Built Machines

Media Number -KENR8106-09

Publication Date -01/10/2017

Date Updated -18/10/2017

i02742697

Flywheel Housing - Remove and Install

SMCS - 1157-010

Removal Procedure

Table 1

Required Tools			
Tool	Part Number	Part Description	Qty
A	138-7575	Link Bracket	1
B	1P-0510	Driver Group	1

Start By:

- Remove the electric starting motor. Refer to Disassembly and Assembly, "Electric Starting Motor- Remove and Install".
- Remove the flywheel and ring gear. Refer to Disassembly and Assembly, "Flywheel - Remove".

NOTICE

Keep all parts clean from contaminants.

Contaminants may cause rapid wear and shortened component life.

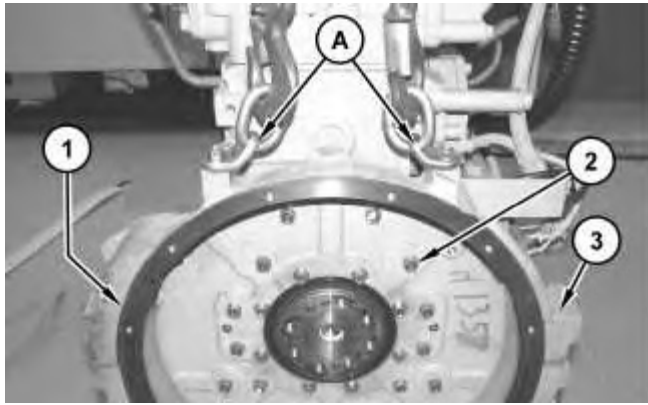

Illustration 1

g01374571

1. Install Tooling (A), and a suitable lifting device onto flywheel housing (3).
2. Remove bolts (2) and the washers that secure flywheel housing (3) to the cylinder block.
3. Remove flywheel housing (3). The weight of flywheel (3) is approximately 29 kg (65 lb).
4. Remove gasket (1) (not shown).

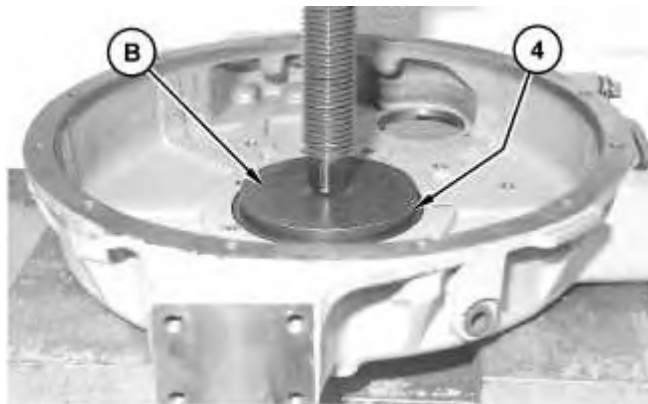

Illustration 2

g01374572

5. Use Tooling (B) in order to remove the oil seal (4) (not shown).

Installation Procedure

Table 2

Required Tools			
Tool	Part Number	Part Description	Qty
A	138-7575	Link Bracket	1
B	1P-0510	Driver Group	1

NOTICE

Keep all parts clean from contaminants.

Contaminants may cause rapid wear and shortened component life.

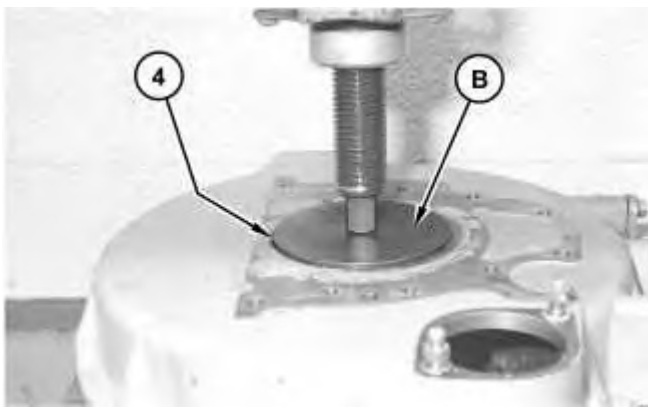

Illustration 3

g01374614

1. Use Tooling (B) in order to install the oil seal (4) (not shown).

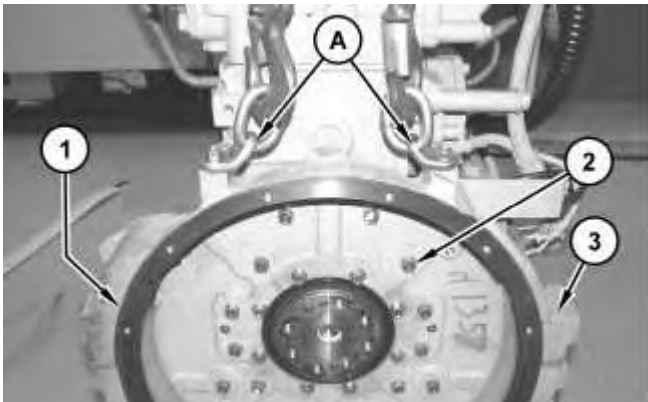

Illustration 4

g01374571

2. Check the condition of two dowels (not shown). If dowels are damaged, use new parts for replacement.
3. Clean old gasket (1) (not shown) from the mating surfaces of the cylinder block and the flywheel housing. Install a new gasket on the cylinder block.
4. Place flywheel housing (3) in position on the cylinder block.
5. Install the washers and bolts (2) in order to secure flywheel housing (3) to the cylinder block.
6. Remove Tooling (A).

End By:

**Thank you very much
for your reading.**

**Please click here to buy
After you pay.**

**Then, you can
download the complete
manual instantly.
No waiting.**