

Product: BACKHOE LOADER

Model: 427F2 BACKHOE LOADER HWK

Configuration: 427F2 Side Shift Backhoe Loader HWK00001-UP (MACHINE) POWERED BY C3.4 Engine

Disassembly and Assembly

422F2, 427F2, 428F2, 432F2, 434F2 and 444F2 Backhoe Loaders Powertrain

Media Number -UENR3743-01

Publication Date -01/06/2015

Date Updated -05/06/2018

i06194852

Axle Housing (Service Brakes, Differential and Bevel Gear) - Disassemble

SMCS - 3256-015; 3258-015; 3260-015; 4251-015

Disassembly Procedure

Table 1

Required Tools			
Tool	Part Number	Part Description	Qty
A	202-7965	Spanner Wrench	1
B	1P-2321	Combination Puller	1
C	235-2784	Adjusting Tool Gp	1
D	8H-0663	Bearing Puller Gp	1

Start By:

- a. Remove the axle housing.

NOTICE

Keep all parts clean from contaminants.

Contaminants may cause rapid wear and shortened component life.

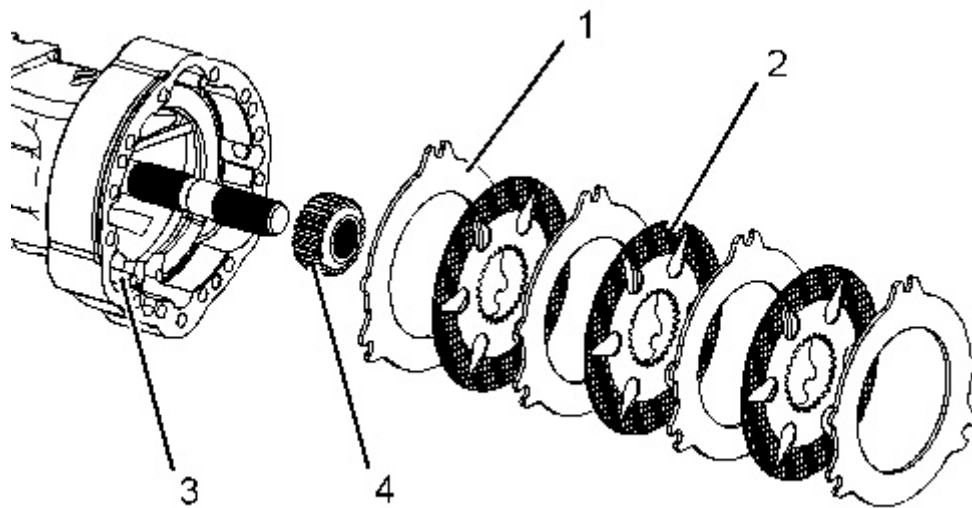

Illustration 1

g01636808

1. Remove plates (1), brake discs (2), and brake hub (4) from the brake cylinder assembly. Remove dowels (3).

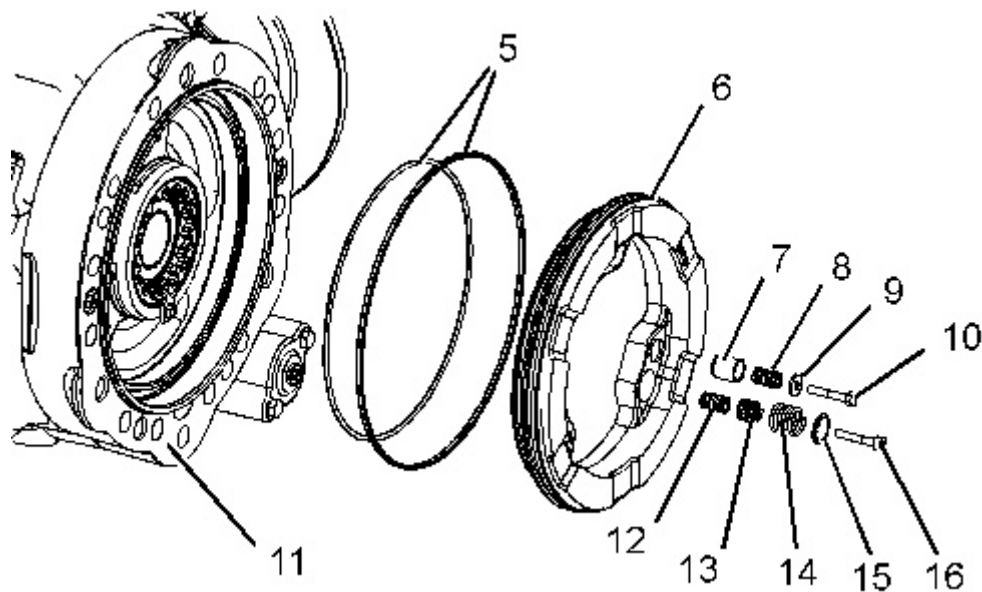

Illustration 2

g01636809

! WARNING

Personal injury can result from being struck by parts propelled by a released spring force.

Make sure to wear all necessary protective equipment.

Follow the recommended procedure and use all recommended tooling to release the spring force.

2. Remove bolts (10), washers (9), bushing (8), and spacer (7). Remove bolts (16), retainers (15), springs (14), springs (13), and bushings (12), as an assembly. Use a suitable pry bar and remove brake piston (6) from brake cylinder assembly (11). Remove O-ring seals (5) from brake piston (6). Repeat this step for the opposite side.
-

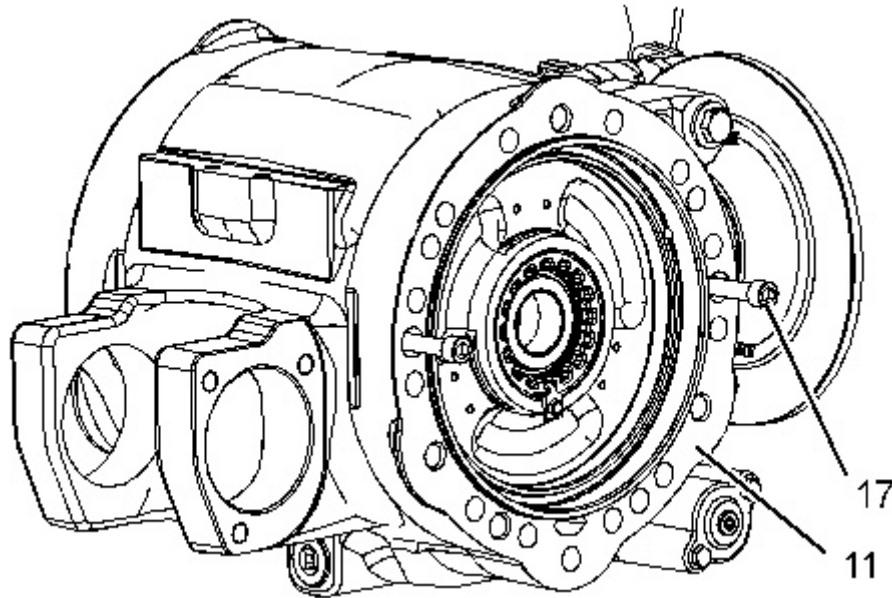

Illustration 3

g01636811

3. Remove bolts (17) from brake cylinder assembly (11).
-

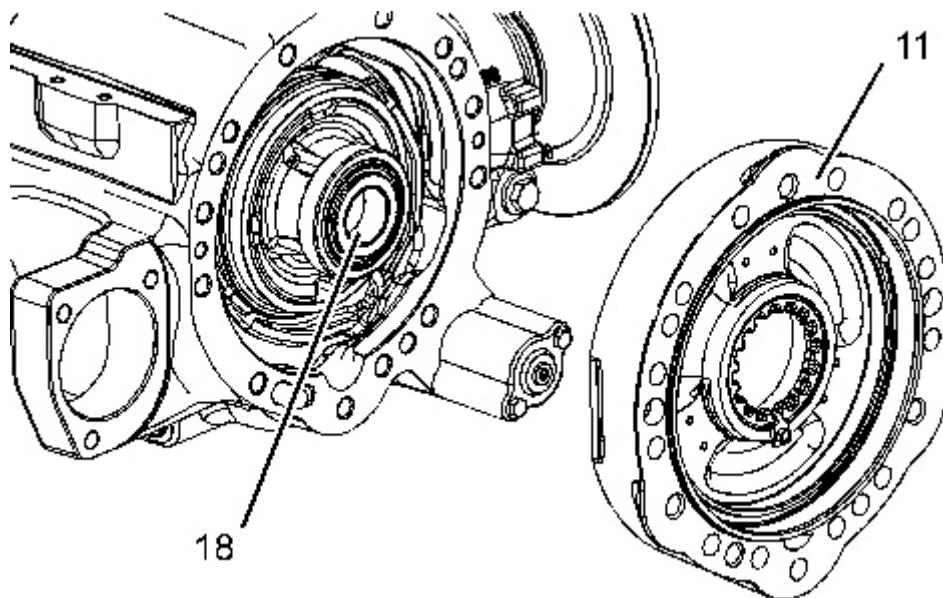

Illustration 4

g01636812

Note: Before you remove brake cylinder assembly (11), make location marks for installation purposes.

4. Remove brake cylinder assembly (11).
5. Repeat Step 3 and Step 4 for the opposite side.
6. Remove the differential and bevel gear assembly (18) from the bevel gear side of the center housing.

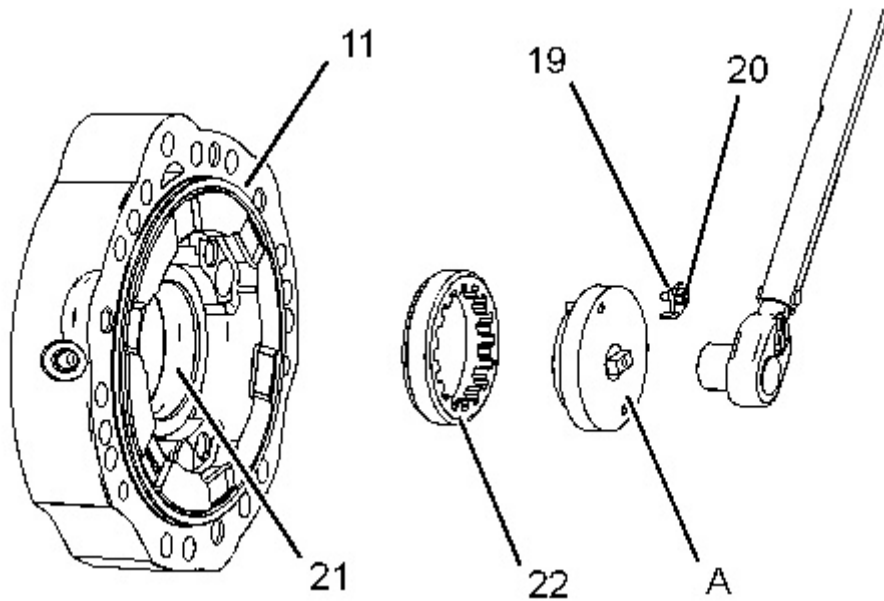

Illustration 5

g01637013

7. Remove bolt (20) and retainer (19). Use Tooling (A) to remove spanner nut (22). If necessary, remove bearing cup (21) from brake cylinder assembly (11). Repeat this step for the opposite side.
-

**Thank you very much
for your reading.**

**Please click here to buy
After you pay.**

**Then, you can
download the complete
manual instantly.**

No waiting.