

Product: EXCAVATOR

Model: 320E LRR EXCAVATOR PNL

Configuration: 320E LRR Excavator PNL00001-UP (MACHINE) POWERED BY C6.6 Engine

Disassembly and Assembly C6.6 Engines for Caterpillar Built Machines

Media Number -KENR9249-07

Publication Date -01/09/2015

Date Updated -19/06/2017

i05909542

Vibration Damper and Pulley - Install

SMCS - 1205-012

Installation Procedure

Table 1

Required Tools			
Tool	Part Number	Part Description	Qty
A	-	Guide Stud M14 x1.5 by 100 mm	1
B	227-4393	E18 Torx Socket	1
C	8T-3052	Degree Wheel	1
D	-	Guide Stud M12 x1.75 by 50 mm	2

NOTICE

Do not lubricate the crankshaft front seal. The crankshaft front seal must be installed dry.

NOTICE

Keep all parts clean from contaminants.

Contaminants may cause rapid wear and shortened component life.

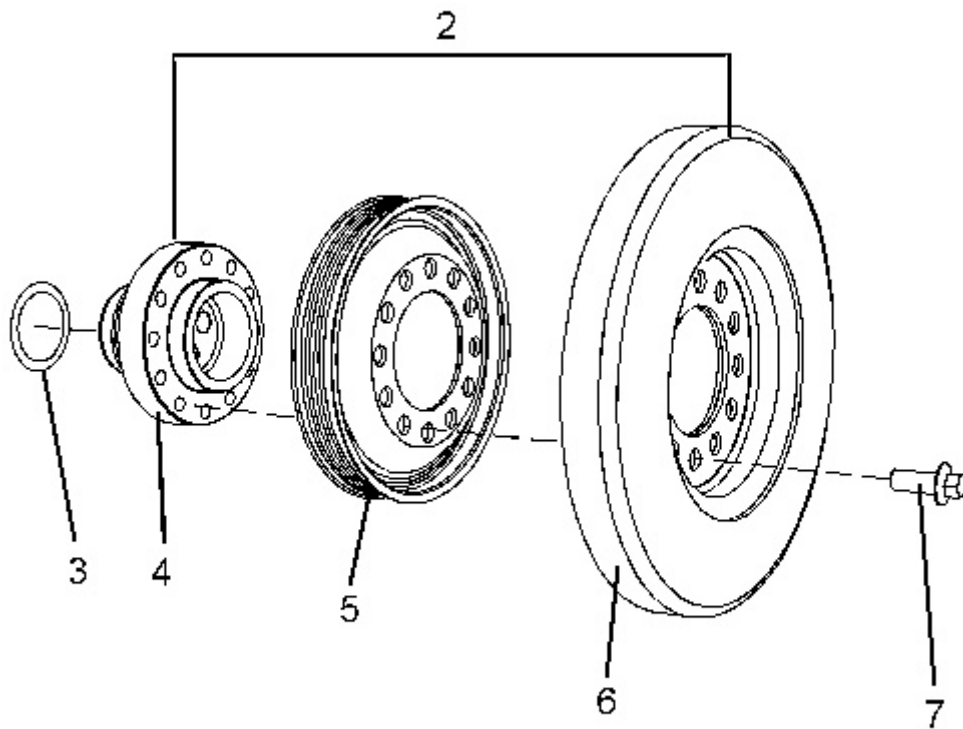

Illustration 1

g02368018

1. Ensure that the crankshaft adapter and the front of the crankshaft are clean and free from damage.
2. Inspect vibration damper (6) for damage. If necessary, replace the vibration damper.
3. If necessary, follow Step 3.a through Step 3.e in order to install vibration damper, crankshaft pulley to crankshaft adapter.
 - a. Place crankshaft adapter (4) onto a suitable support.
 - b. Install Tooling (D) crankshaft adapter (4) .
 - c. Install crankshaft pulley (5) and vibration damper (6) over Tooling (D) .
 - d. Install bolts (7) to the crankshaft pulley assembly.

Note: Evenly space bolts (7) around the crankshaft pulley assembly.
 - e. Tighten bolts (7) to a torque of 115 N·m (85 lb ft).

4. If necessary, install friction shim (3) . Follow Step 4.a through Step 4.b in order to install friction shim (3) .
 - a. Install friction shim (3) .
 - b. Install a new front seal to the front cover. Refer to Disassembly and Assembly, "Crankshaft Front Seal - Remove and Install" for the correct procedure.
5. Install Tooling (A) to the crankshaft.

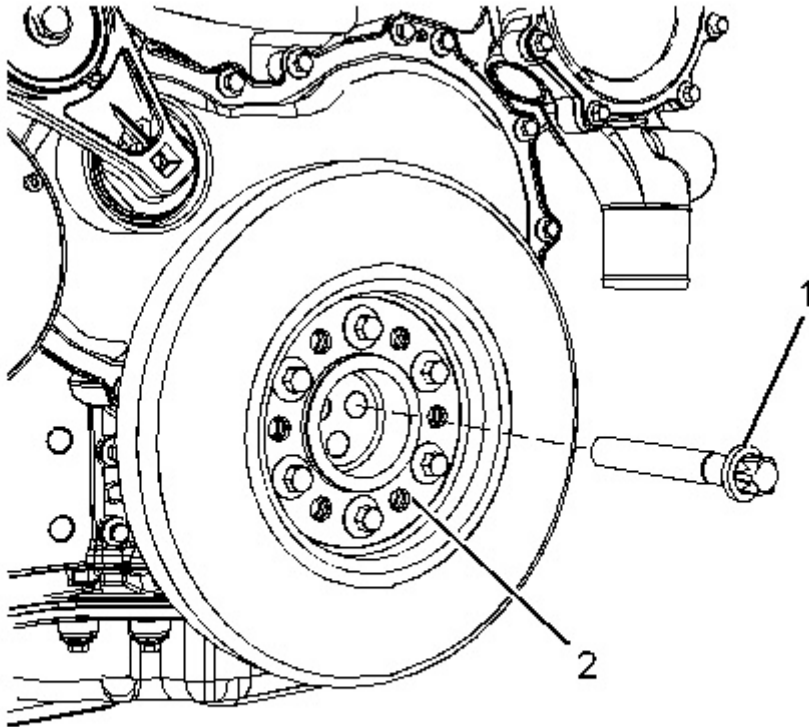

Illustration 2

g02458316

6. Install crankshaft pulley assembly (2) onto the crankshaft.

Note: Do not lubricate the front seal or the seal face of the crankshaft pulley assembly.
7. Install one Torx screws (1) to crankshaft pulley assembly (2) hand tighten.
8. Remove Tooling (A) .
9. Install remaining Torx screws (1) to crankshaft pulley assembly (2) .
10. Use a suitable tool in order to prevent the crankshaft from rotating. Tighten Torx screws (1) to a torque of 40 N·m (29 lb ft).

**Thank you very much
for your reading.**

**Please click here to buy
After you pay.**

**Then, you can
download the complete
manual instantly.
No waiting.**