

Illustration 2

g00578529

2. Remove exhaust manifold (2) and gasket (3) from the engine.

Installation Procedure

NOTICE

Keep all parts clean from contaminants.

Contaminants may cause rapid wear and shortened component life.

1. Make sure that the cylinder head and the exhaust manifold are clean and free of carbon and gasket material.
-

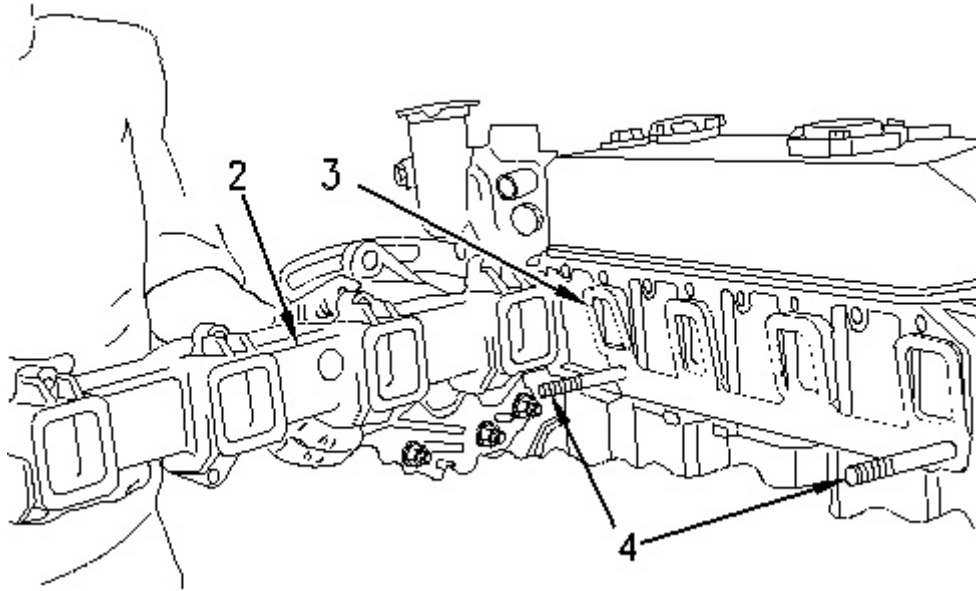

Illustration 3

g00578574

2. Install two guide bolts (4) into two of the bolt holes for the exhaust manifold bolts. The guide bolts are used to keep exhaust manifold gasket (3) and exhaust manifold (2) in position on the cylinder head during installation.
3. Put a new exhaust manifold gasket (3) in position on the engine. It is not necessary to use a sealer on the exhaust manifold gasket.

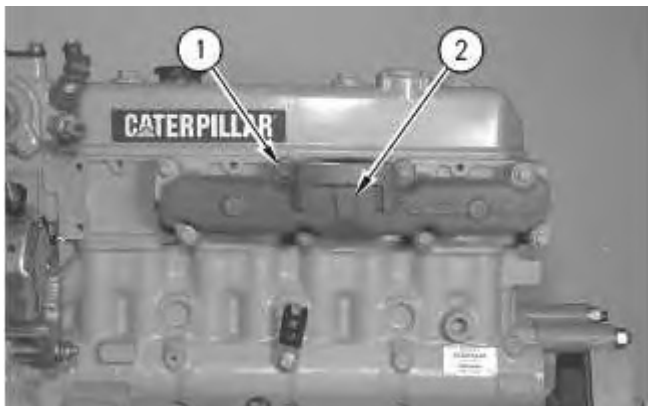

Illustration 4

g00578523

4. Put exhaust manifold (2) in position on the engine.
5. Install six of the eight bolts (1) and remove the two guide bolts. Install the remaining two bolts (1).
6. Tighten eight bolts (1) in an outward pattern. Begin with the center of the exhaust manifold. Tighten bolts (1) to a torque of 18 N·m (13 lb ft).

Product: SKID STEER LOADER

Model: 236 SKID STEER LOADER 4YZ

Configuration: 236 246 252 262 Skid Steer Loader 4YZ04000-UP (MACHINE) POWERED BY 3034 Engine

Disassembly and Assembly 3034 Engine for Caterpillar Built Machines

Media Number -SEN5013-08

Publication Date -01/11/2008

Date Updated -14/11/2008

i01333774

Inlet Manifold - Remove

SMCS - 1058-011

Removal Procedure

Start By:

- A. Remove the fuel injection lines. Refer to Disassembly and Assembly, "Fuel Injection Lines - Remove and Install".

NOTICE

Keep all parts clean from contaminants.

Contaminants may cause rapid wear and shortened component life.

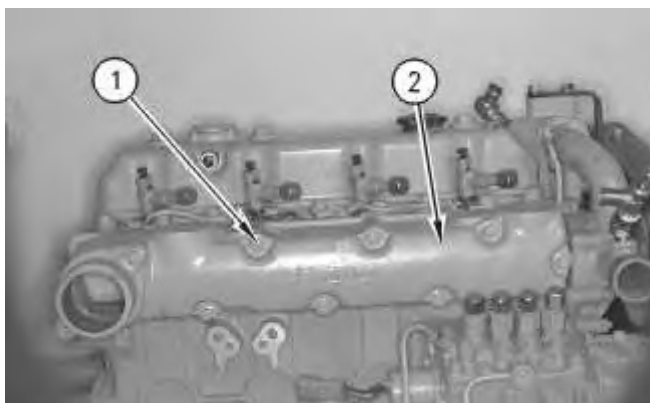

Illustration 1

g00580923

1. Remove eight bolts (1) from air inlet manifold (2) .

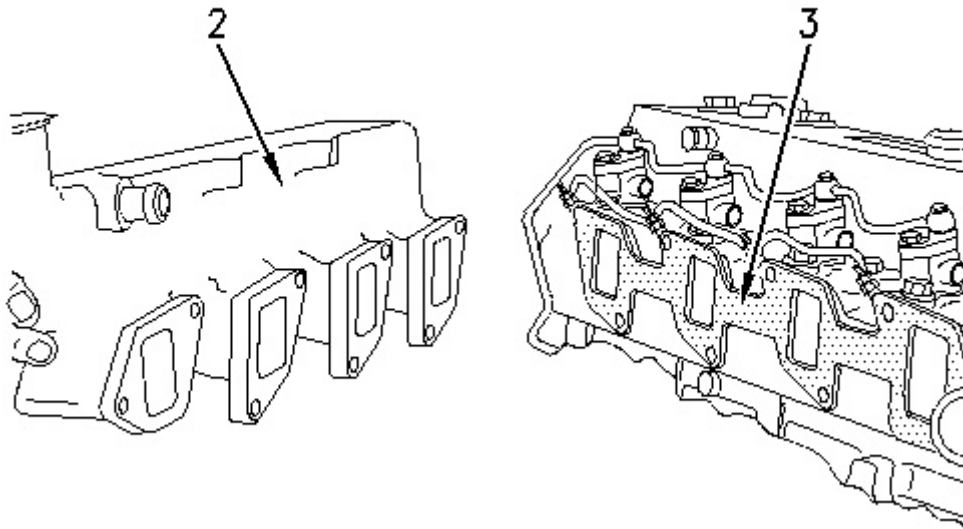

Illustration 2

g00580932

2. Remove air inlet manifold (2) and gasket (3) from the engine. Check the condition of gasket (3). If gasket (3) is worn or damaged, use a new part for replacement.
-

Product: SKID STEER LOADER

Model: 236 SKID STEER LOADER 4YZ

Configuration: 236 246 252 262 Skid Steer Loader 4YZ04000-UP (MACHINE) POWERED BY 3034 Engine

Disassembly and Assembly 3034 Engine for Caterpillar Built Machines

Media Number -SEN5013-08

Publication Date -01/11/2008

Date Updated -14/11/2008

i01333848

Inlet Manifold - Install

SMCS - 1058-012

Installation Procedure

NOTICE

Keep all parts clean from contaminants.

Contaminants may cause rapid wear and shortened component life.

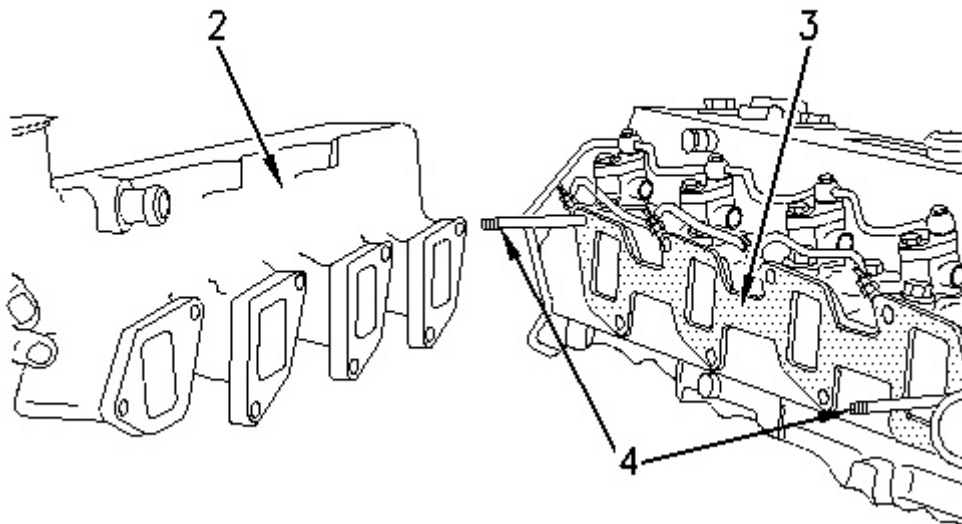

1. Install two guide bolts (4) into the cylinder head, as shown. The guide bolts are used to keep gasket (3) and air inlet manifold (2) in position on the cylinder head during installation.
2. Put gasket (3) in position on the engine.

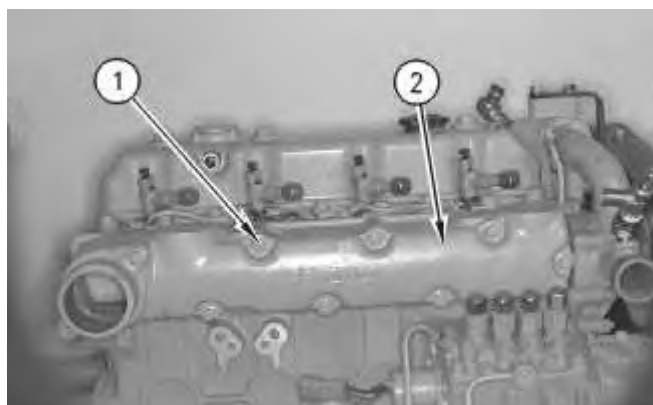

Illustration 2

g00580923

3. Put air inlet manifold (2) in position on the engine.
4. Install six of the eight bolts (1) and remove two guide bolts (4). Install the remaining two bolts (1).
5. Tighten bolts (1) to a torque of 22 N·m (16 lb ft).

End By: Install the fuel injection lines. Refer to Disassembly and Assembly, "Fuel Injection Lines - Remove and Install".

**Thank you very much
for your reading.**

**Please click here to buy
After you pay.**

**Then, you can
download the complete
manual instantly.
No waiting.**