TN60DA, TN60SA, TN70DA, TN70SA, TN75DA, TN75SA, TN85DA, TN95DA REPAIR MANUAL COMPLETE CONTENTS

SECTION 00 - GENERAL	2
SECTION 10 - ENGINE	2
SECTION 18 - CLUTCH	9
SECTION 21 - TRANSMISSIONS	11
SECTION 23 - FWD TRANSFER BOX AND AUTO FWD	14
SECTION 25 - FRONT AXLE (FWD)	15
SECTION 27 - REAR MECHANICAL DRIVE	17
SECTION 31 - MECHANICAL POWER TAKE-OFF	17
SECTION 33 - BRAKING SYSTEM	18
SECTION 35 - HYDRAULIC SYSTEM	18
SECTION 41 - STEERING	21
SECTION 44 - AXLES AND WHEELS	22
SECTION 50 - CAB AIR CONDITIONING SYSTEM	22
SECTION 55 - ELECTRICAL SYSTEM	23
SECTION 90 - PLATFORM, CAB, BODYWORK	29

The following pages are the collation of the contents pages from each section and chapter of the TNDA and TNSA Series Repair manual. Complete Repair part # 87393595.

The sections used through out all New Holland product Repair manuals may not be used for each product. Each Repair manual will be made up of one or several books. Each book will be labeled as to which sections are in the overall Repair manual and which sections are in each book.

The sections listed above are the sections utilized for the TNDA and TNSA Series Tractors.

OVERHAUL

Op. 10 001 10

ENGINE

Removal

⚠ DANGER ⚠

Lift and handle all heavy parts using suitable lifting equipment.

Make sure that assemblies or parts are supported by means of suitable slings and hooks. Make sure that no one is standing in the vicinity of the load to be lifted.

⚠ WARNING ⚠

Always use appropriate tools to align fixing holes. NEVER USE YOUR FINGERS OR HANDS.

1. Carry out operation **18 110 10**, Clutch Removal (see Sect. 18).
2. Remove the clogged air filter sensor connection (1).

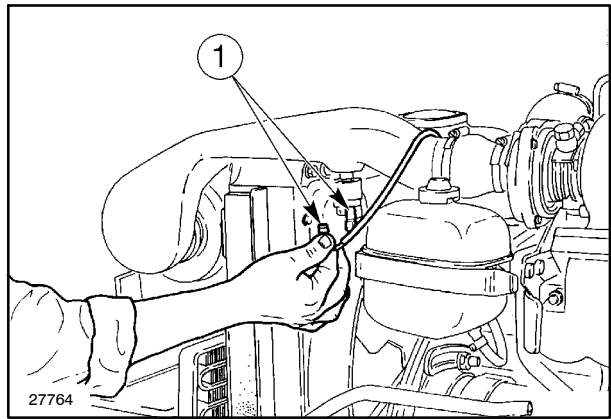

4

3. Disconnect the horn connection (1).

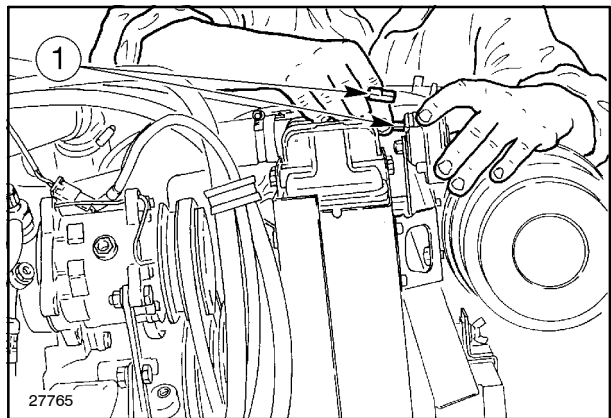

5

4. Loosen the clamps (1, 2 and 3) and remove the inlet manifold.

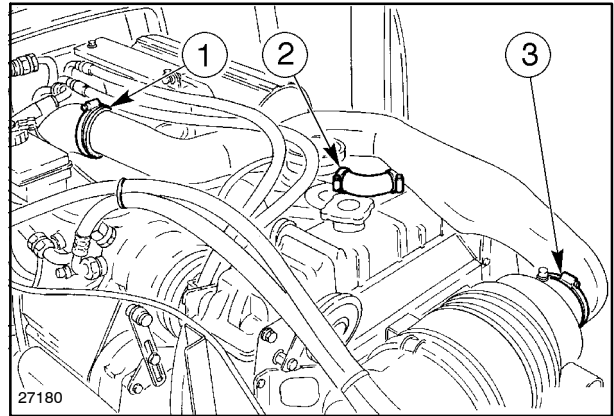

6

5. Unscrew the band clamps and detach the upper (2) and lower radiator hoses, detach the radiator bracket (1).
6. Position two fixed stands under the front axle support and under the engine. Attach the chains so that the engine is balanced during hoisting and position two wood blocks between the support and the front axle, to prevent oscillation.

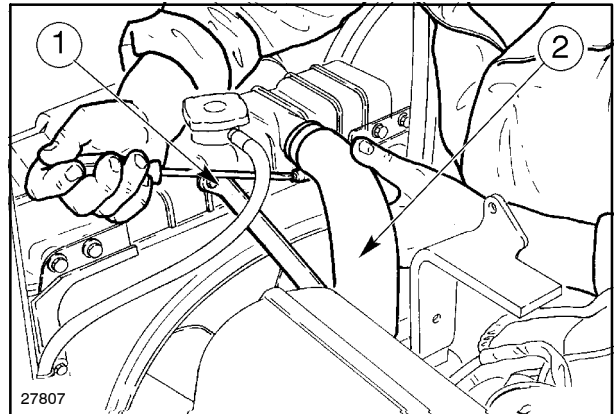

7

7. Loosen the front axle support retaining bolts (1).
8. Remove the engine from the axle-support unit.

Installation



Always use appropriate tools to align fixing holes. NEVER USE YOUR FINGERS OR HANDS.

Apply the prescribed tightening torques. See the "Contents".

1. Install the front axle-support unit on the engine.
2. Connect and secure the upper and lower radiator hoses and the connecting bracket.
3. Install and secure the inlet manifold.
4. Connect the horn and clogged air filter connections.
5. Carry out operation **18 110 10**, Clutch Installation (see Sect. 18).

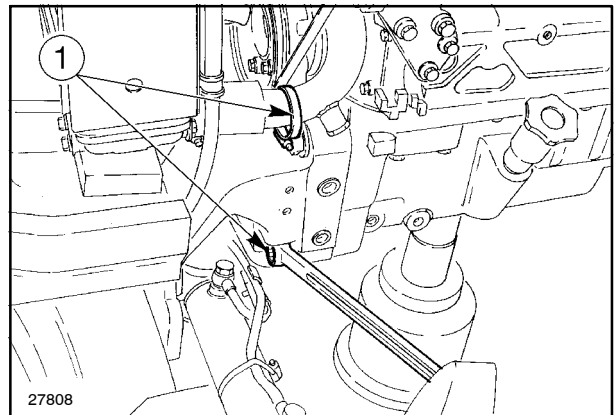

8

Op. 10 001 30**Compression Test**

In case of poor engine performance, in addition to checking the fuel injection system (injection nozzles and injection pump), also test the compression on each cylinder.



Do not use matches, lighters, blow torches or any form of naked flame as a source of light when inspecting the engine due to the presence of inflammable fluids and vapor.

Compression Ratio

The compression ratio is a measure of the quantity of air drawn into the cylinder, and provides an indication of the efficiency of the sealing elements in the cylinder (piston rings and valves).

Uniform compression in all the cylinders ensures that they all perform an equal amount of work, provided that each cylinder is injected with the same quantity of fuel at the right time.

Low compression not only reduces engine performance, it also causes incomplete fuel combustion due to the lack of available combustion air.

The engine therefore gives poor performance with excessive fuel consumption and, consequently, exhaust smoke and restriction of the exhaust passages.

As the compression ratio also varies with the temperature of the engine (cold engines produce lower compression values than hot engines), the compression should only be tested when the engine is at normal operating temperature.

Compression should be tested using the compression test kit **380000303**, as follows:

- 1) Run the engine until it reaches normal operating temperature;
- 2) Switch off the engine;
- 3) Disconnect the lead from the engine stop electromagnet on the injection pump in order to close the valve and block the flow of fuel to the injectors;
- 4) Remove the injector from the cylinder to be tested;

- 5) Turn the engine over a few times with the starter motor in order to expel any carbon residue;
- 6) Fit the dummy injector **380000617**, in place of the injector removed previously, interposing the copper sealing washer;
- 7) Connect the compression test instrument **380000303** and take readings while turning the engine over with the starter motor.

On engines in perfect working order, with the sump oil at approx. 40 °C (104 °F) at sea level (760 mm [29.92 in.] of mercury) and at an engine speed of 200 to 280 rpm, the compression should be 25 to 27 bar (369 to 398 psi).

- 8) Test the compression on the other cylinders, repeating steps 4-5-6-7, bearing in mind that:

The minimum permissible compression on a used engine is 21 bar (313 psi).

The maximum permissible compression difference between cylinders is 3 bar (43 psi).

Every 100 meters (109.36 yards) above sea level corresponds to a reduction in compression by approx. 1%.

Uniform Compression

Although high compression is important, it is more important for smooth engine running that compression is uniform in all cylinders.

Low compression readings

If extremely low pressure readings are obtained on one cylinder it is advisable to repeat the test.

Before testing this time, pour approx. one spoonful of engine oil into the cylinder through the injector bore.

Turn over the engine a few times to distribute the oil evenly over the cylinder walls, and then repeat the test.

If the second test readings are significantly higher, suspect worn piston rings, out-of-round or damaged pistons or cylinders.

If the second test readings are not higher, the problem will be the valves.

On the other hand, if the second test reading shows only a slight improvement, the problem will be due to both the valves and the rings.

Op. 10 001 54

Disassembly



Handle all parts carefully. Do not put your hands or fingers between parts. Wear suitable safety clothing - safety goggles, gloves and shoes.

1. Disconnect the thermostarter union (2), the inlet line retaining unions from the injection pump, the injectors, and the piping (1).

2. Disconnect the fuel filter lines (2) to the injection pump and the support retaining bolts (1). Remove the fuel filter.

3. Disconnect the hydraulic piping (2) the oil filter (1) retaining bolts complete with the support, and remove from the engine.

4. Remove the lift (2) and steering (1) hydraulic pumps and remove the piping (3).

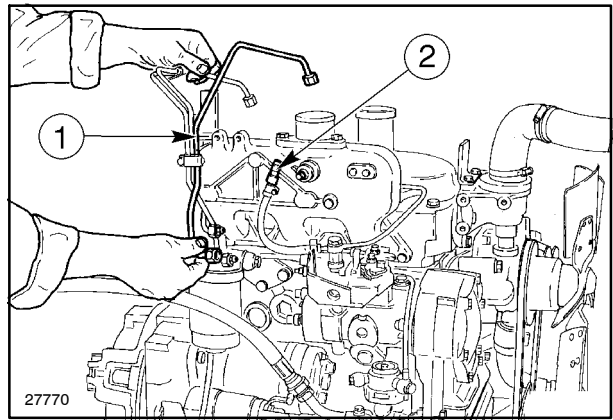

9

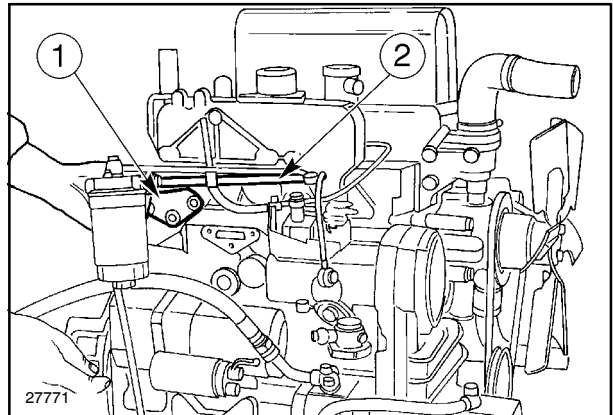

10

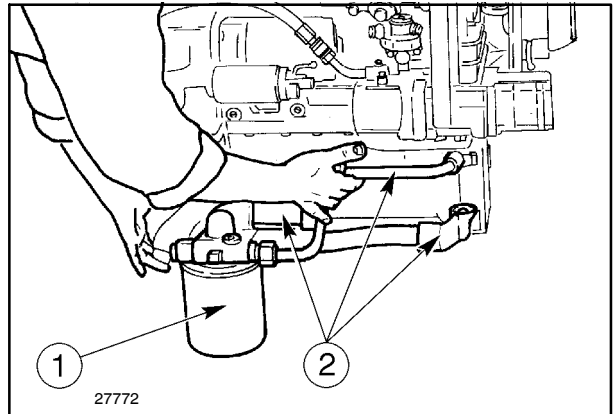

11

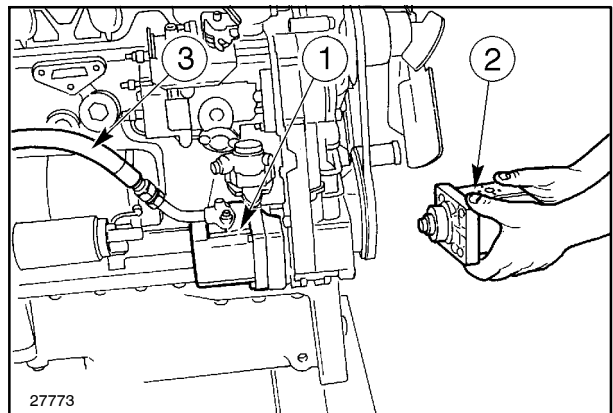

12

5. Unscrew the retaining bolts and remove the starter motor (1).

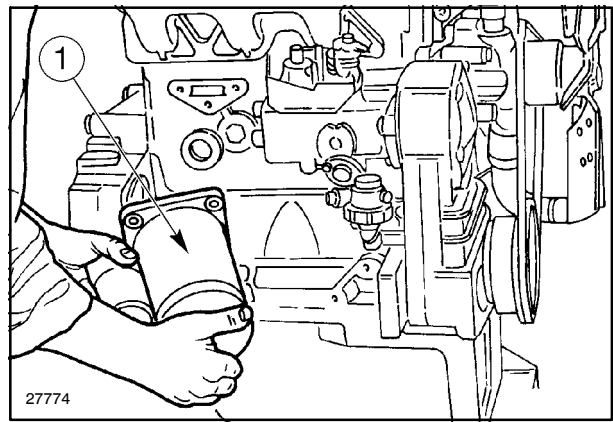

13

6. Unscrew the retaining bolts and remove the cover (3), loosen the retaining nut (2) on the injection pump (1) and remove from the opposite side.

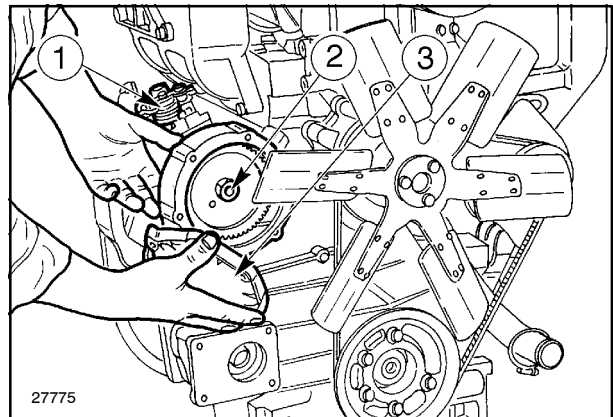

14

7. Unscrew the retaining nuts and remove the fuel pump (1).

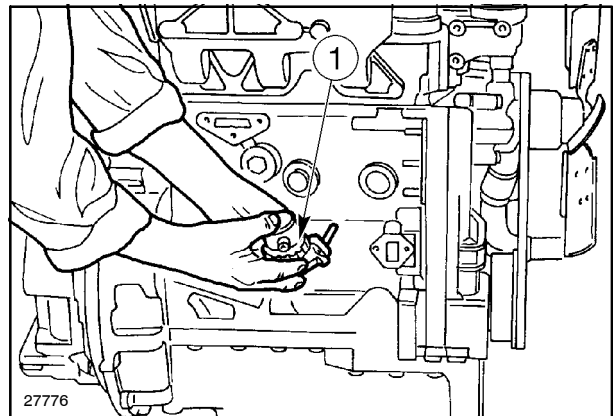

15

8. Unscrew the retaining bolts and remove the exhaust silencer (1) complete with the vertical pipe. On models with horizontal exhaust pipes, remove when disassembling the engine.

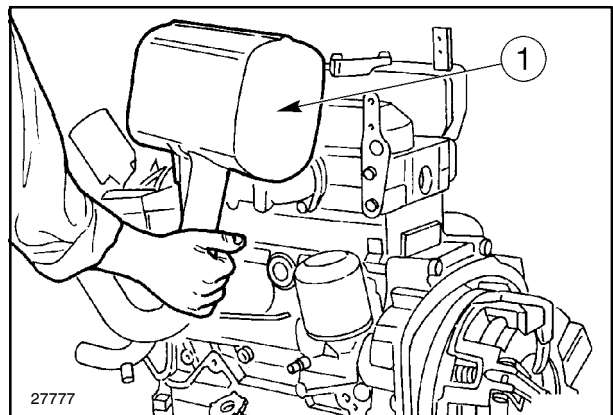

16

9. Unscrew the retaining bolts, remove the alternator (1) and recover the drive belt.
10. Remove the engine oil filter (2).

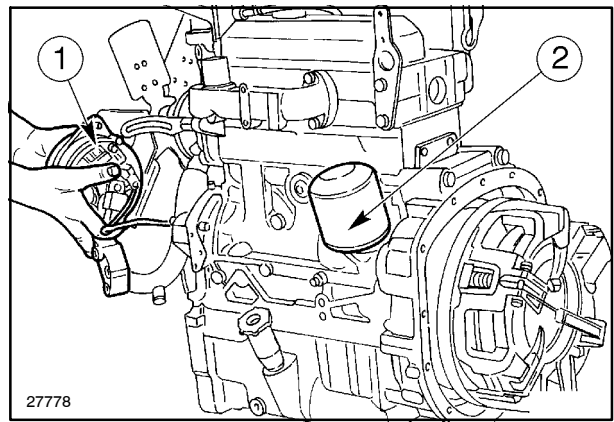

17

11. Unscrew the retaining bolts and remove the exhaust manifold (1).

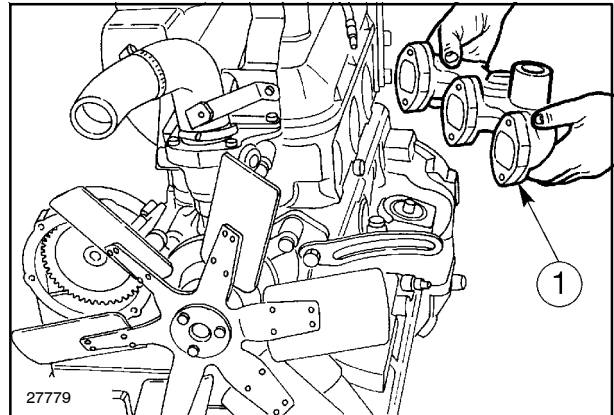

18

12. Unscrew the retaining bolts and detach the coolant pump hose (1).

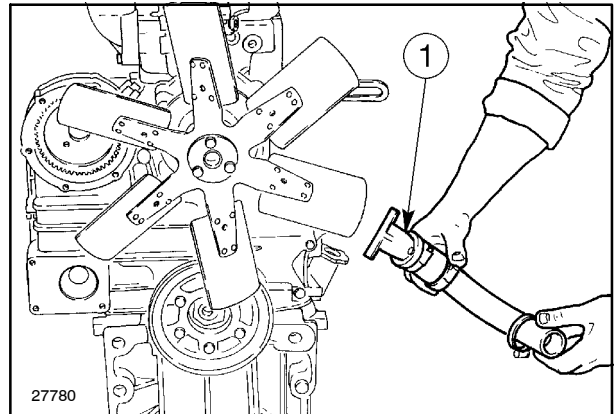

19

13. Unscrew the retaining bolts and detach the coolant pump (1) complete with fan (2).

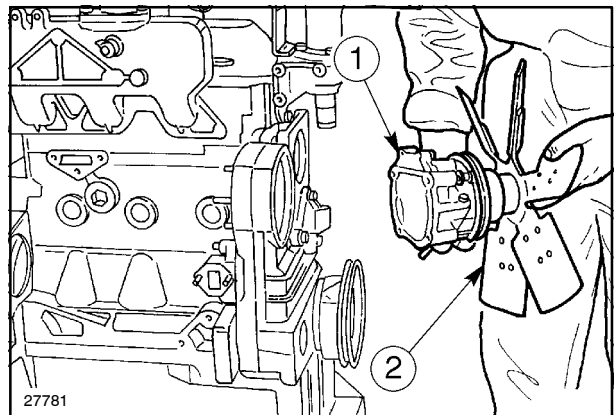

20

14. Unscrew the retaining bolts and detach the coolant pump support (1).

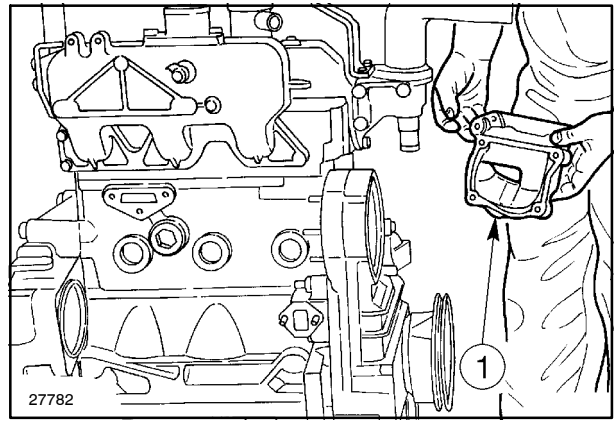

21

15. Unscrew the retaining bolts and disconnect the thermostatic valve unit (2) complete with bracket (1).

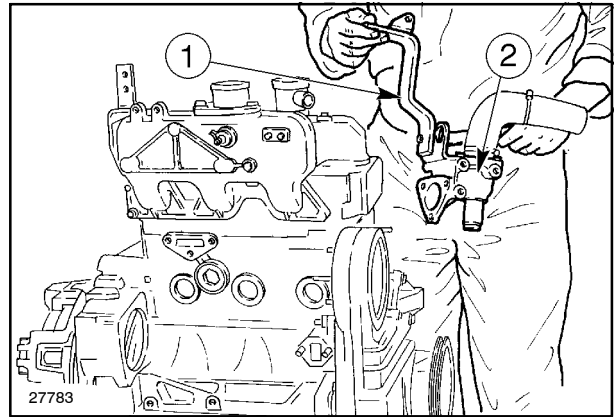

22

16. Unscrew the retaining bolts and remove the inlet manifold (1).

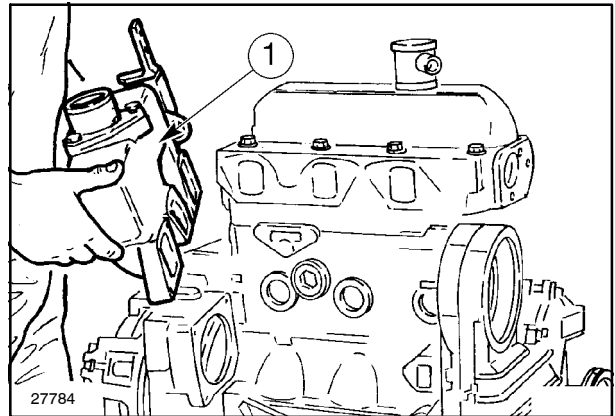

23

17. Remove the injector mounting nuts, the underlying spherical washers, then the supports and the injectors themselves.
18. Remove the rocker cover bolts (1), washers and seals, and then the rocker cover (2) and the gasket.

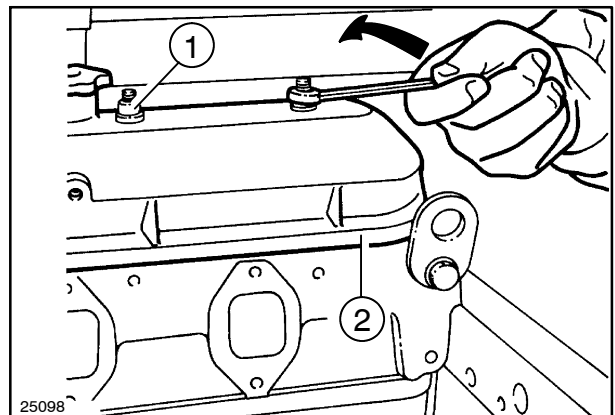

24

19. Remove the rocker shaft retaining bolts (2), then remove the entire rocker shaft assembly (1).

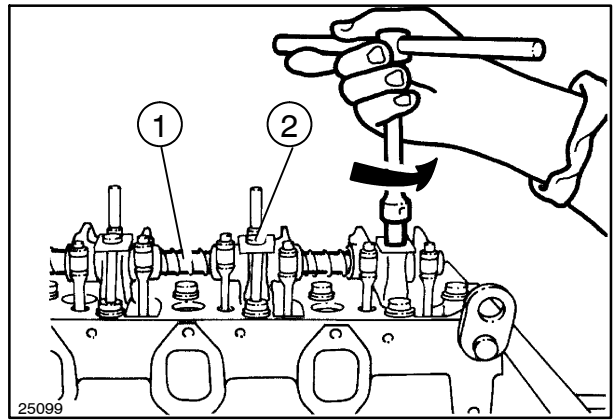

25

20. Remove the valve collets (1) and extract the pushrods (2).

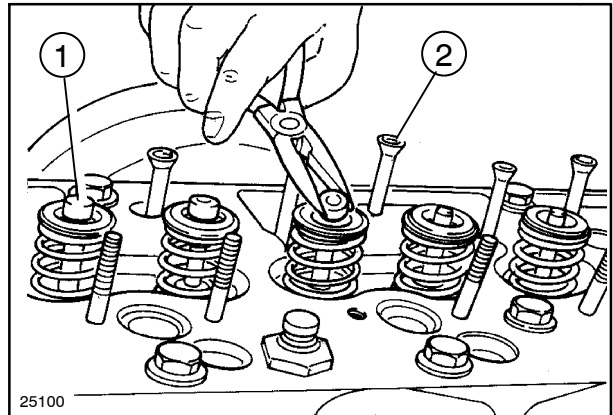

26

21. Unscrew the cylinder head bolts (1) and remove the head using a hoist and lifting hook **380000216**.

22. Remove the cylinder head gasket.

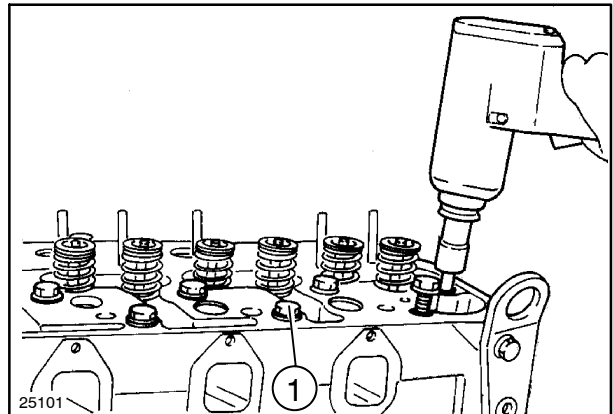

27

23. Unscrew the sump pan retaining bolts and remove the sump pan using a hoist, lifting hook **380000216** and lifting chain with eyeholes.

24. Remove the half-gaskets (1) and (3) between the crankcase and sump pan and the gasket (2) between the timing gear carrier and sump pan.

NOTE: When reinstalling gaskets (1) and (2, fig. 28), apply RHODORSIL CAF1 silicone sealing compound to the mating surfaces.

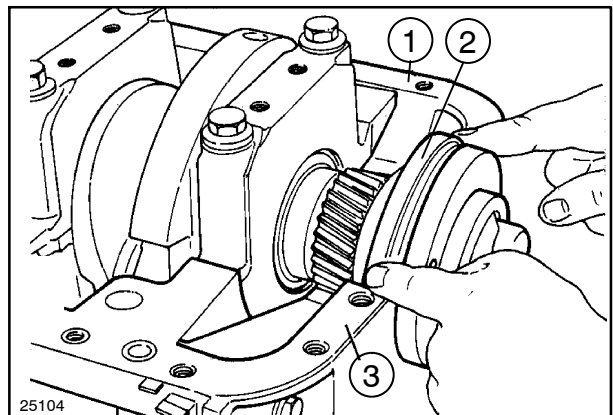

28

25. Remove the gasket (1) between the flywheel carrier and the sump pan.

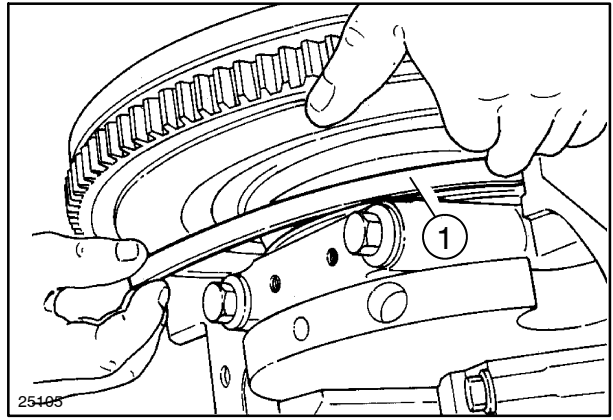

29

26. Unscrew retaining bolts (1) and remove the complete oil pump (non-turbo version shown).

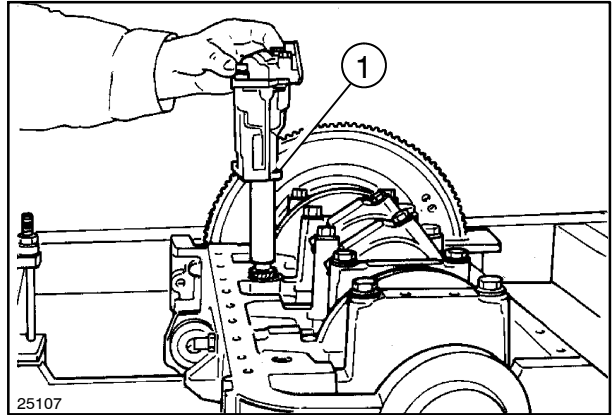

30

27. Unscrew the retaining bolts (2) and remove the crankshaft pulley (1).

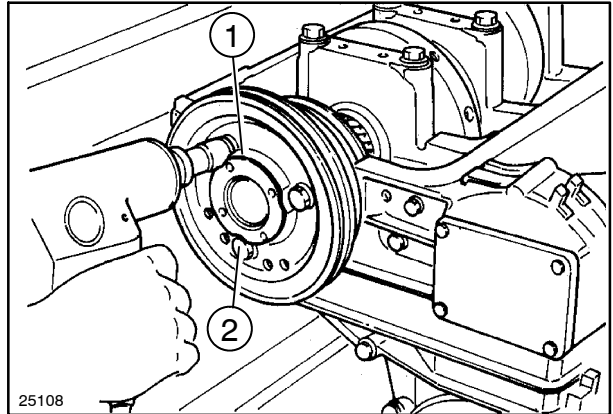

31

28. Straighten the lock tab, securing the crankshaft against rotation and unscrew nut (1).

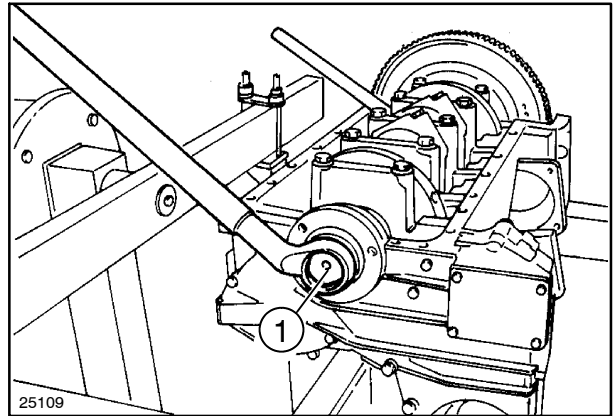

32

29. Pull the pulley hub off the crankshaft using tool **380000226** (1) and recover the woodruff key.

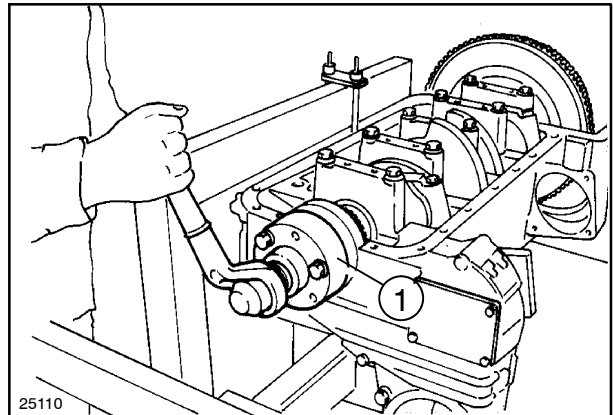

33

30. Unscrew the retaining bolt (1) and remove the timing cover and gasket.

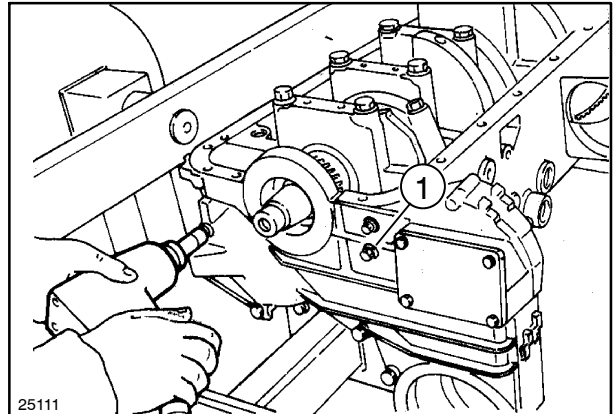

34

31. Unscrew the retaining bolts and remove the lift pump drive gear carrier (1).

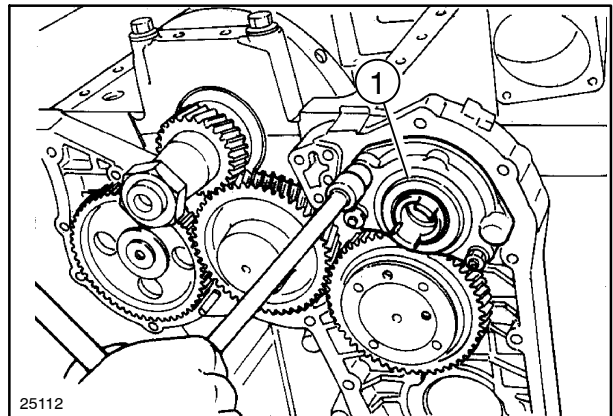

35

**Thank you very much
for your reading.**

**Please click here to buy
After you pay.**

**Then, you can
download the complete
manual instantly.
No waiting.**