

WDI504
Tier 4B (final)
Self-Propelled Windrower

SERVICE MANUAL

Part number 47824877

1st edition English

January 2015



Link Product / Engine

Product	Market Product	Engine
WD1504	North America	F4HFE413H*B001

Contents

INTRODUCTION

Engine	10
[10.001] Engine and crankcase	10.1
[10.202] Air cleaners and lines	10.2
[10.206] Fuel filters	10.3
[10.216] Fuel tanks	10.4
[10.218] Fuel injection system.....	10.5
[10.254] Intake and exhaust manifolds and muffler	10.6
[10.310] Aftercooler.....	10.7
[10.400] Engine cooling system	10.8
[10.414] Fan and drive	10.9
[10.500] Selective Catalytic Reduction (SCR) exhaust treatment.....	10.10
Transmission	21
[21.900] Hydraulic pump drive.....	21.1
Front axle system	25
[25.310] Final drives	25.1
Rear axle system	27
[27.550] Non-powered rear axle	27.1
Hydrostatic drive	29
[29.100] Transmission and steering hydrostatic control	29.1
[29.202] Hydrostatic transmission	29.2
[29.218] Pump and motor components.....	29.3
Brakes and controls	33
[33.110] Parking brake or parking lock	33.1
Hydraulic systems	35
[35.000] Hydraulic systems.....	35.1

[35.100] Main lift system.....	35.2
[35.105] Charge pump.....	35.3
[35.304] Combination pump units	35.4
[35.415] Header or attachment tilting system	35.5
Steering.....	41
[41.101] Steering control	41.1
Cab climate control	50
[50.200] Air conditioning.....	50.1
Electrical systems.....	55
[55.000] Electrical system	55.1
[55.019] Hydrostatic drive control system	55.2
[55.100] Harnesses and connectors.....	55.3
[55.640] Electronic modules.....	55.4
[55.DTC] FAULT CODES.....	55.5
Platform, cab, bodywork, and decals.....	90
[90.124] Pneumatically-adjusted operator seat.....	90.1
[90.150] Cab.....	90.2
[90.151] Cab interior.....	90.3
[90.154] Cab doors and hatches	90.4

Engine and crankcase - Overview

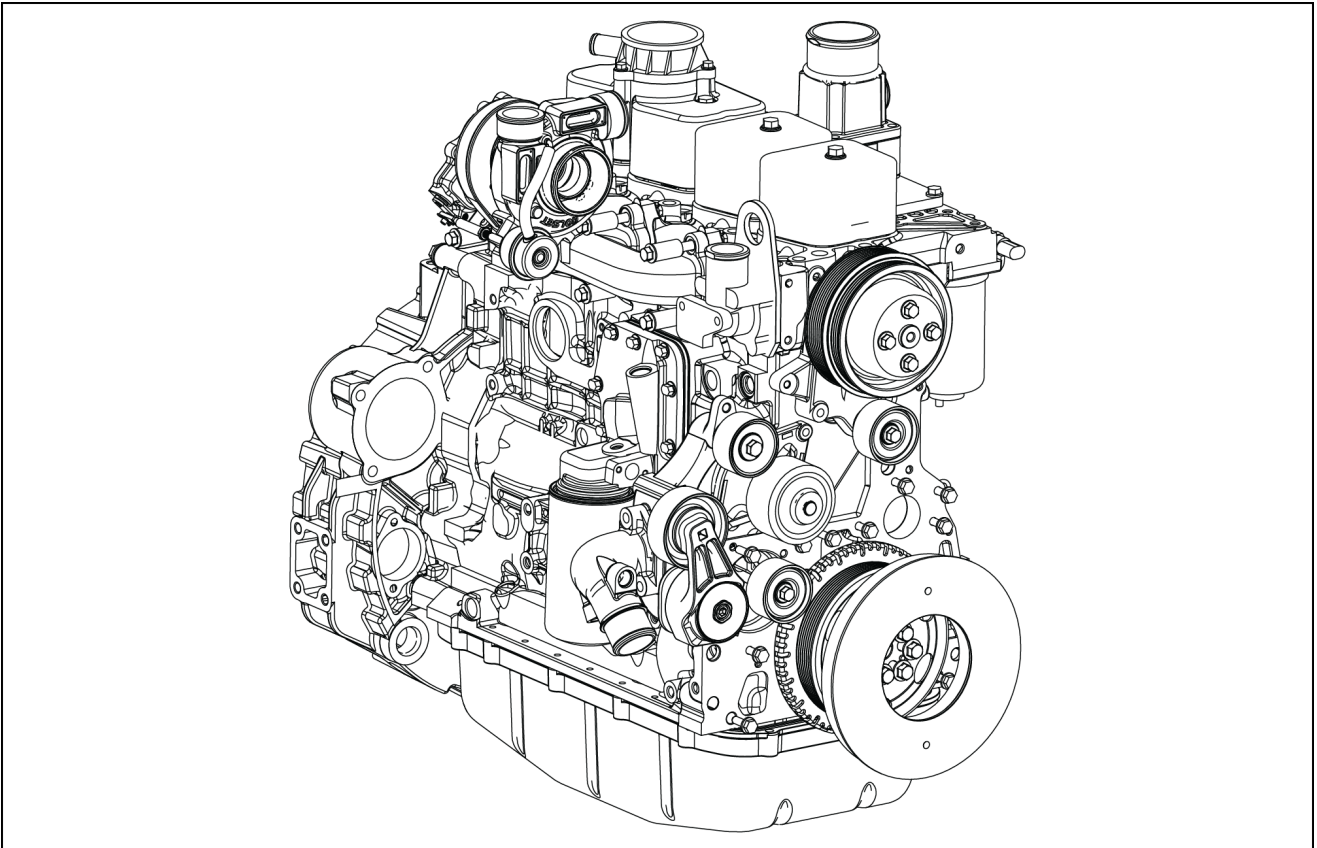

NHIL14WR01174HA 1

The NEF Tier IV engine is a 4-cylinder turbocharged and after cooled unit, having a bore of 104 mm (4.4 in) and a stroke of 132 mm (5.2 in) which generates a displacement of 4.5 L (274 in³).

The engine uses a electronically controlled hi-pressure injection pump and has been designed to meet current emission regulations and must only be serviced by an authorized service agent.

All engines feature cross flow cylinder heads, with the inlet and exhaust manifolds on opposite sides of the cylinder head. The fuel and air combustion process, takes place in the specially designed bowl in the crown of the pistons.

NOTE: The FRONT of the engine is the water pump end. The REAR of the engine is the flywheel end. In this section, right and left correspond to the above when standing at the rear of the engine looking at the flywheel end with the water pump end away from you.

Cylinder block assembly

The cylinder block is an alloy cast iron with deep cylinder skirts, and water jackets for cooling the cylinders. The cylinder bores are machined integral with the cylinder block, during the manufacturing process.

Cylinders are in line and vertical and numbered 1 to 4 from the front (fan end) to the rear of the engine. They can be bored oversize for the fitment of sleeves, which are available in service.

In the following procedures and illustrations the engine is shown removed from the vehicle however there are certain operations that can be performed with the engine installed. Where it is necessary to remove the engine use a suitable hoist or overhead gantry and standard engineering procedures. Removal of the engine is described in Chapter 1 of Section 10 of this manual. Dismantle the engine following conventional techniques and by referring to the appropriate overhaul sections of this chapter. Always refer to the specification section as necessary.

NOTE: Where it is necessary to remove additional items to gain access to the components on the engine refer to Engine Removal.

NOTICE: All gaskets, seals, and O-rings must be replaced during reassembly. Where new sealant is to be applied refer to Engine Specifications.

Engine and crankcase - Check fluid level

NOTE: Before checking the engine oil level, park the windrower on a level surface, stop the engine, set the park brake, and wait for a short period (minimum 5 minutes) to allow the oil to drain back into the oil pan.

1. Clean the dipstick area of debris and remove dipstick (1) wipe it clean, and reinsert it fully.

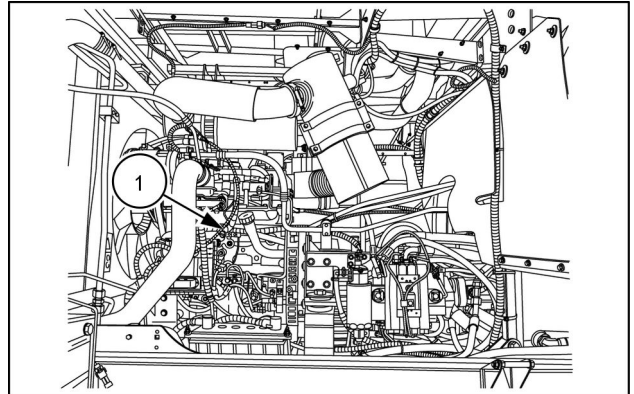

NHIL14WR00302AA 1

2. Pull the dipstick out again and check the oil level. The oil level should be at the top of the flattened area (1).

NOTICE: Do not operate the engine with the oil level below the "lower" mark on the dipstick. Damage to the engine may occur.

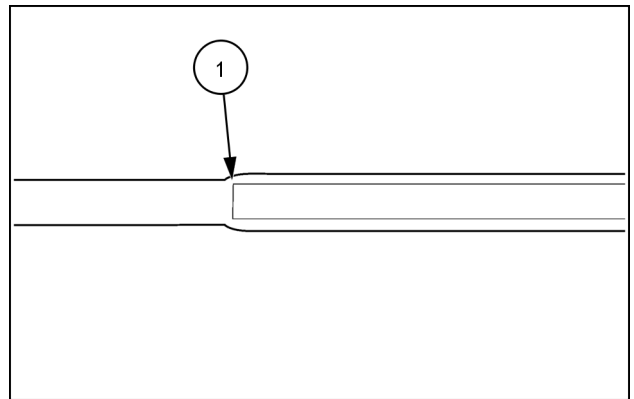

10041134A 2

Adding engine oil

1. Clean any debris from around the crankcase fill cap **(1)** on the right-hand side of the windrower.
2. Remove the fill cap **(1)** and add oil as required.
3. Install the fill cap and check the dipstick.

NOTE: Windrowers equipped with the optional auxiliary hydraulic kit will have the fill cap **(2)** figure 4 located on the right-hand frame support.

NOTICE: Do not operate the engine with the oil level above the "upper" mark. The excess oil will be burned off or pushed out the crankcase breather and give a false impression of oil consumption.

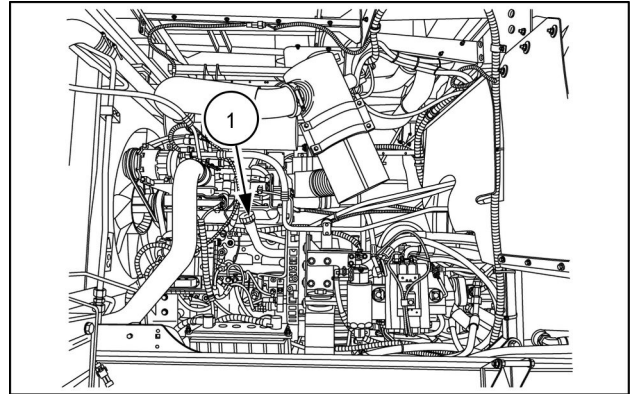

NHIL14WR00302AA 3

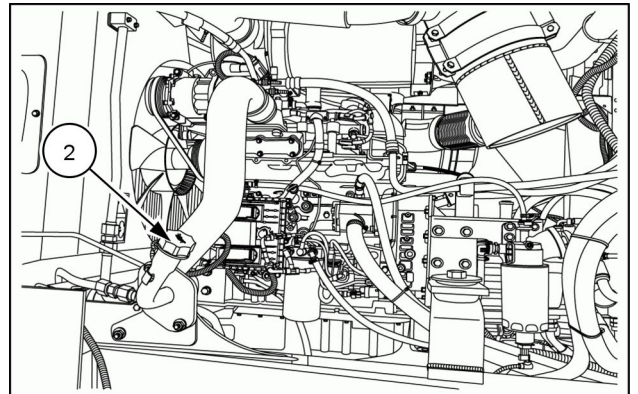

NHIL14WR00704AA 4

Engine and crankcase - Drain fluid

1. Warm the engine to operating temperature. Park the windrower on a level surface. Center the steering wheel, set the park brake, and stop the engine.

NOTICE: Clean the area around each check plug, fill cap, dipstick, etc. before removal. Failure to clean these areas may allow contamination to enter the system.

2. Remove the engine oil drain plug (1) and catch the oil in a suitable container.

NOTE: If the oil drains slowly, it may help to unscrew the filler cap for the engine oil.

3. Replace the drain plug after the oil has been drained.

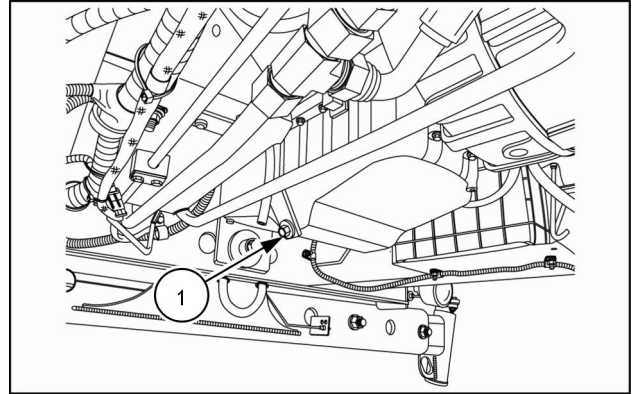

NHIL14WR00701AA 1

4. Clean the oil filter area. Unscrew and discard the oil filter (1).

NOTE: Always discard used oil and filters properly.

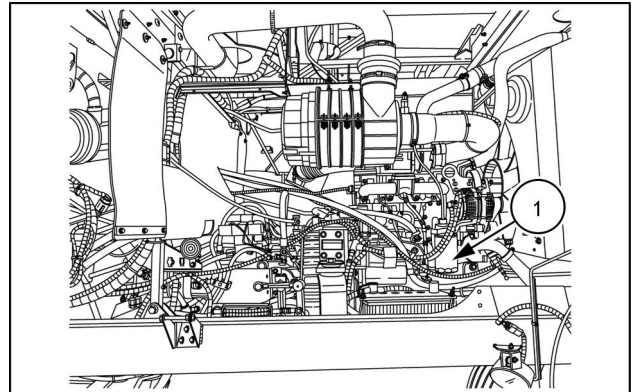

NHIL14WR00303AA 2

Engine and crankcase - Filling

NOTICE: Clean the area around each check plug, fill cap, dipstick, etc. before removal. Failure to clean these areas may allow contamination to enter the system.

1. Clean the oil filter area. Unscrew and discard the oil filter (1).

NOTE: Always discard used oil and filters properly.

2. Apply a thin film of clean oil around the rubber seal of the new oil filter. Screw the new filter onto the filter head until the rubber seal contacts the mounting surface, then tighten an additional 3/4 to 1 full turn. Do not overtighten.

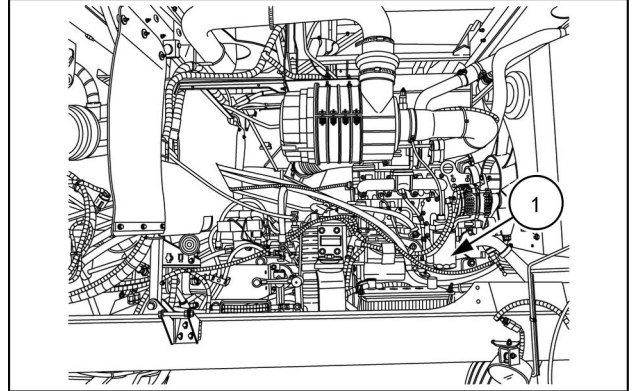

NHIL14WR00303AA 1

3. Clean any debris from around the crankcase fill cap.
4. Remove the filler cap (1) on the right-hand side of the engine, and fill the engine with approximately **12.0 L (12.7 US qt)** of the correct grade and viscosity oil.

NOTE: Windrowers equipped with the optional auxiliary hydraulic kit will have the fill cap (2) Figure 3 located on the right-hand frame support.

5. Run the engine at idle for a few minutes to circulate the oil. Shut the engine off.

NOTICE: Verify the engine oil pressure is in the operating range at start up. If it is not, stop the engine and investigate the cause, or serious engine damage will result.

6. Allow the oil to drain back into the oil pan.
7. Check for oil leaks at the drain plug and oil filter.

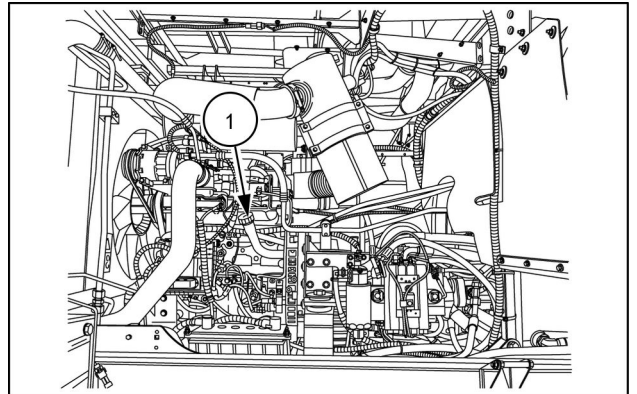

NHIL14WR00302AA 2

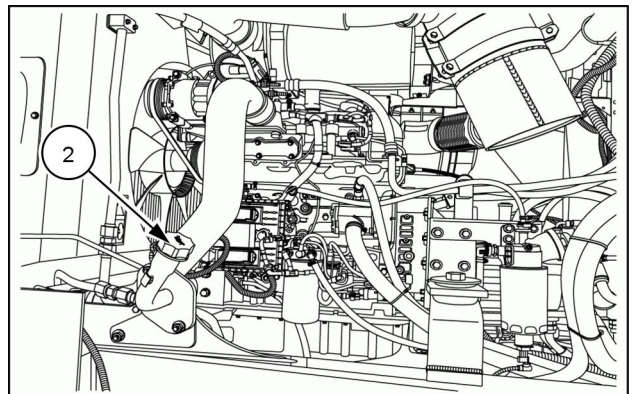

NHIL14WR00704AA 3

8. On the right-hand side of the engine check the dipstick. The oil level should be near the mark (1) but not over. Add oil if required.

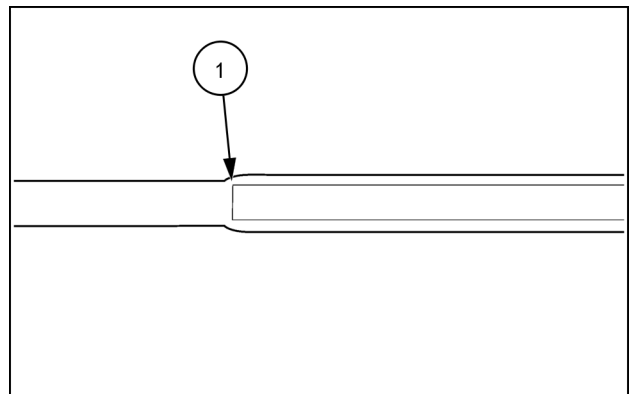

10041134A 4

Engine - Remove - NEF 4 Cylinder

WD1504

NA Draper ready - Factory-fitted to accept draper --- NA Non draper ready - Not fitted for draper header

1. Drain coolant from radiator and engine by opening valve **(1)**. Catch fluid from drain hose in a clean container and save for recycling. Remove the radiator cap to speed up the draining, using caution if the system is hot.

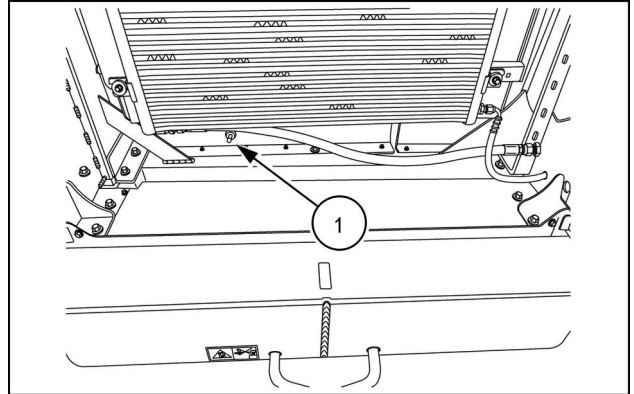

NHIL14WR00316AA 1

2. Remove battery ground cables by removing starter mounting bolt **(1)**.
3. Remove all positive power cables from starter terminal **(2)**.
4. Remove wire **(3)** from starter terminal.
5. Open valve **(4)** if closed, and allow any trapped coolant to drain. Loosen clamp **(5)** and remove heater hose.

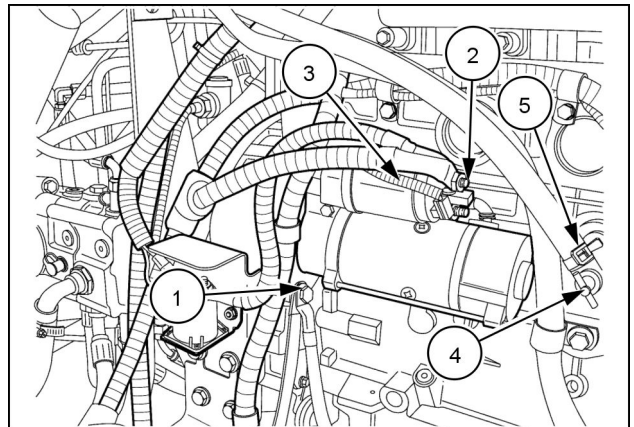

86070630 2

6. Loosen clamp **(1)** and remove lower radiator hose. Also, in like manner, disconnect the upper hose.

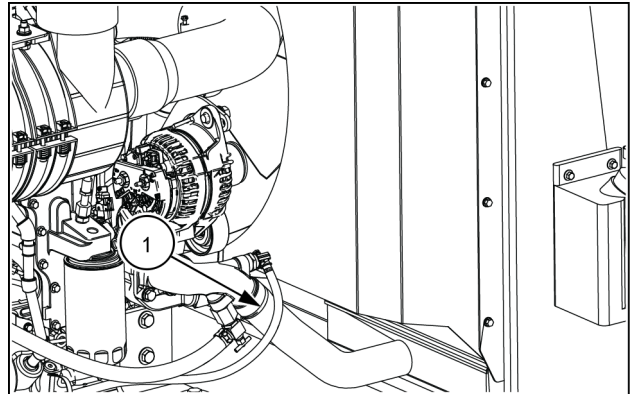

NHIL14WR00719AA 3

7. Using a helper, detach four gas springs (1) from engine area side doors by removing four flange nuts and lock washers.

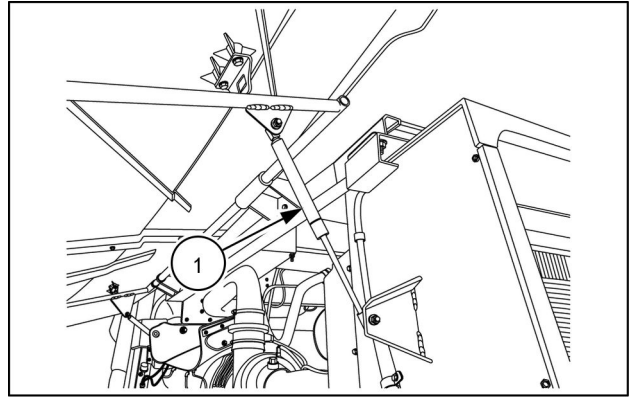

NHIL14WR01126AA 4

8. Remove side doors by removing one bolt (1) and lifting doors upward off the support brackets

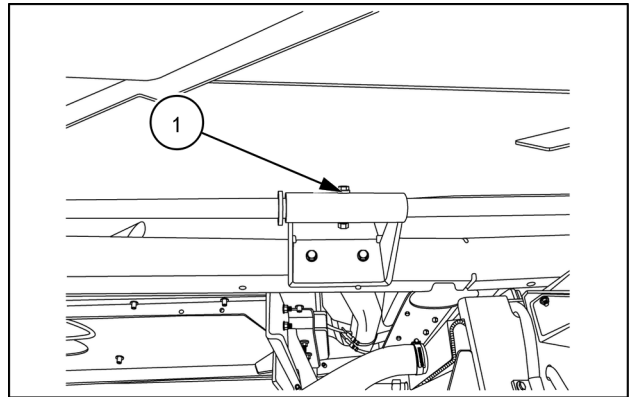

NHIL14WR01127AA 5

9. Loosen the spring clamps (1) and remove tubing from turbo to intercooler, and from intercooler to intake manifold.
10. Push off clip and remove fuel return hose with elbow attached. Likewise push off clip on fuel supply hose. Plug and bag the end of these hoses to keep out contamination.
11. Disconnect harness from fuel injection pump.

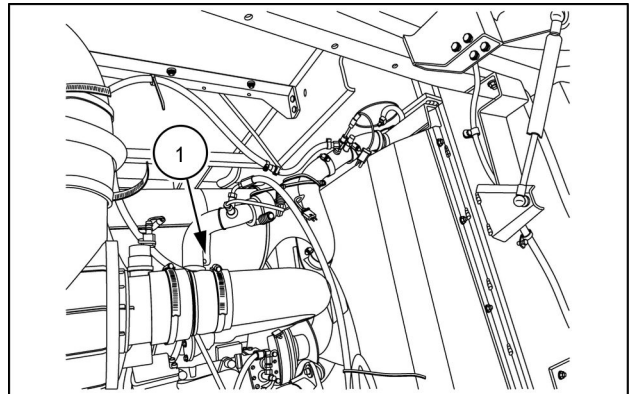

NHIL14WR01116AA 6

12. Remove spring clamp (1) from turbocharger and disconnect the elbow (2) from the turbocharger.

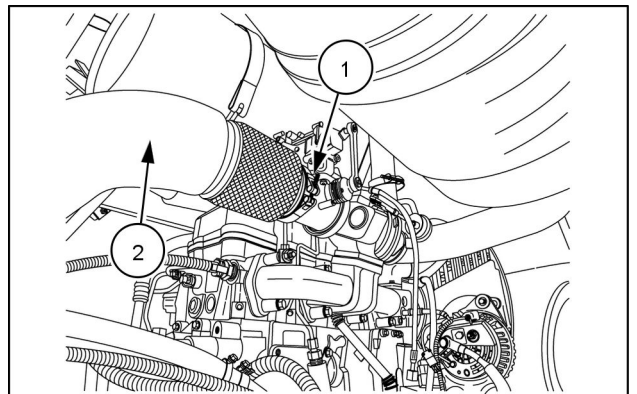

NHIL14WR01115AA 7

13. Disconnect restriction indicator wire (1).
14. Loosen clamps (2) and remove 102 mm (4 in) diameter tubing (3) from air cleaner.

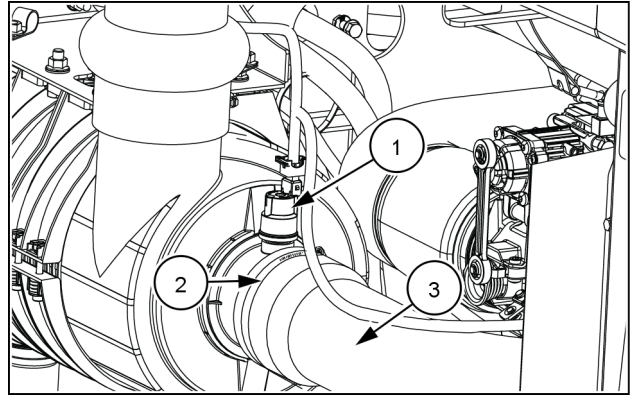

NHIL14WR01135AA 8

15. Tag, label, and disconnect all harnesses (1) that connect the electrical system of the frame of the windrower to the center roof section of the windrower.
16. Remove all cable ties (2) holding the large harness to the center roof section.

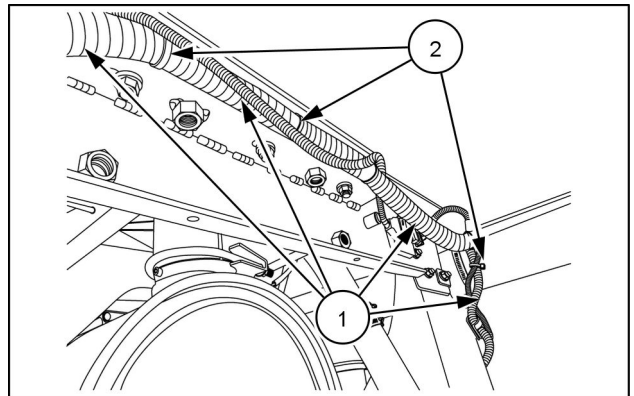

NHIL14WR01120AA 9

17. Squeeze the tabs and disconnect the DEF/AdBLUE® lines (1) that connect the supply module to the dosing module (2).

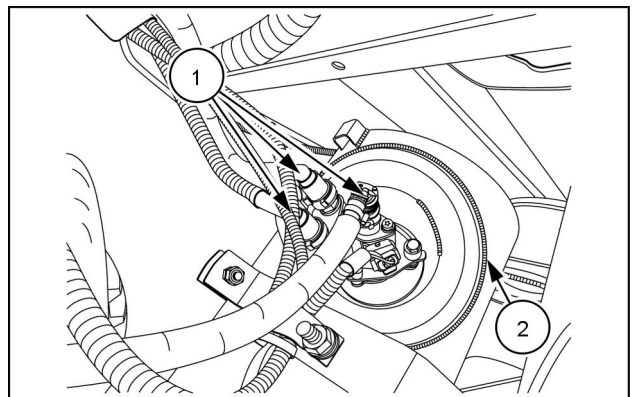

NHIL14WR01119AA 10

18. Remove flange bolts, lock washers and flange nuts (1), to detach hood support frame from radiator side supports and from front upright.
19. Use suitable slings to lift the hood support frame, roof panel, and exhaust after-treatment from the machine.

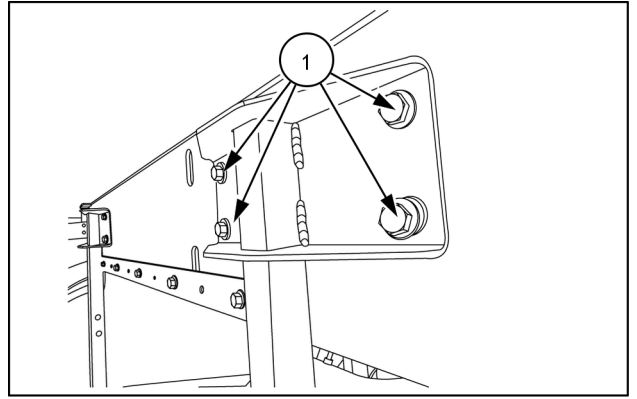

NHIL14WR01122AA 11

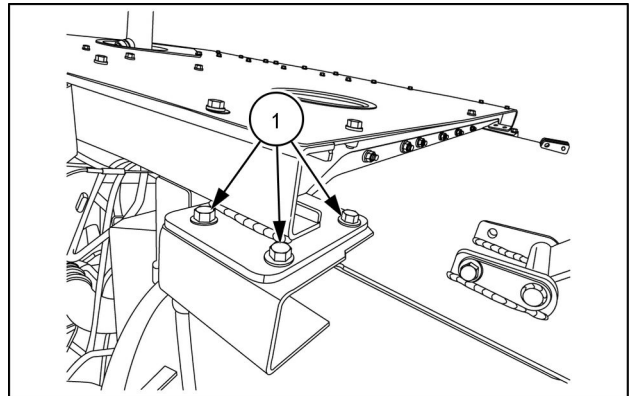

NHIL14WR01121AA 12

NOTICE: Use jackstands to support the hood support frame so that the Selective Catalytic Reduction (SCR) components do not get damaged when setting the hood down.

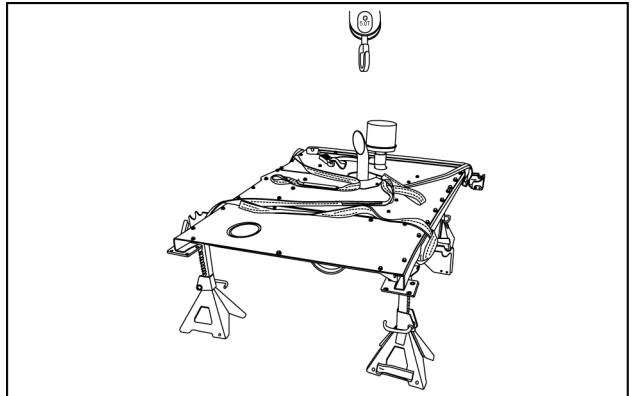

NHIL14WR01124AA 13

20. Disconnect wire harness at both sides of intake air heater (1) if so equipped, and at oil pressure switch (2).

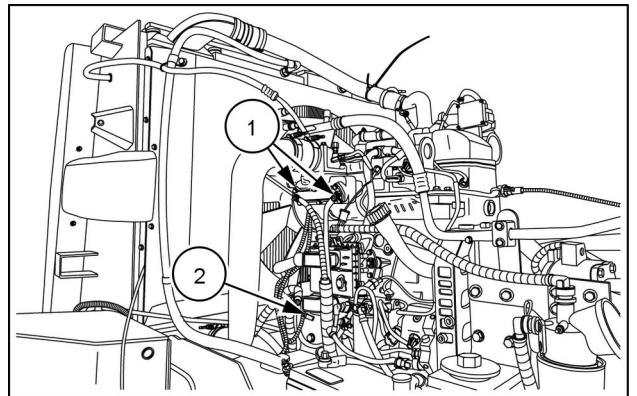

NHIL14WR01123AA 14

21. Disconnect wire connector **(1)** from the compressor.

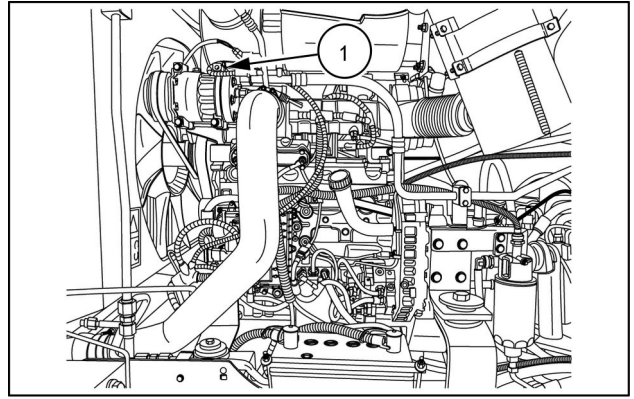

NHIL14WR01125AA 15

22. Disconnect temperature sensor **(1)**.

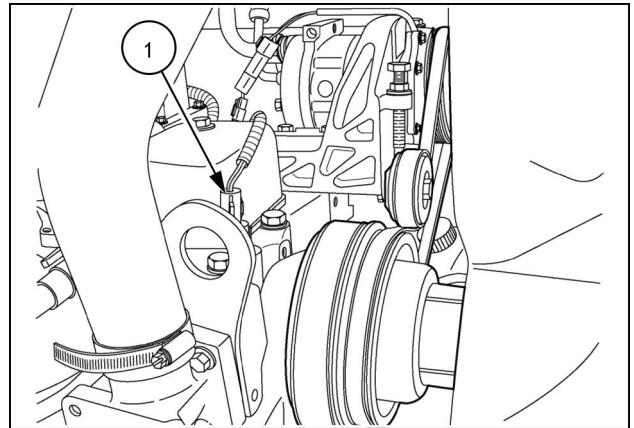

86075189 16

23. Remove three 5/16 x 3-3/4 cap screws with lock washers and flange nuts **(1)** from holes in compressor and through lower mount casting.
24. Remove drive belt and lay compressor over to right side of machine with hoses connected.

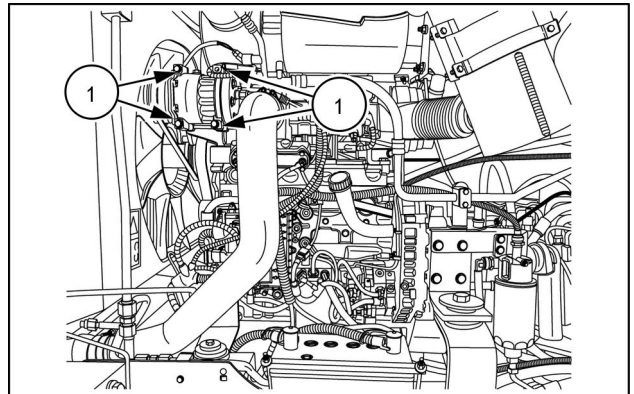

NHIL14WR01125AA 17

25. If equipped with auxiliary pump, remove two hex head flange bolts and lock washers **(1)** to remove pump with PTO drive and hoses attached. Lay over to right side of windrower frame. Save gasket for re-use when reinstalling.

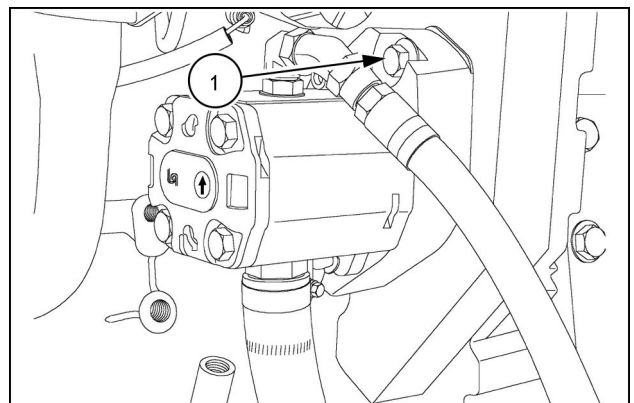

40044943N 18

26. Disconnect cable **(1)** and two wires of harness **(2)** from alternator by removing three nuts. Screw these nuts on the terminals loosely to save for later use.
27. Remove and loosen clamps as necessary to free wiring harness and cables from engine.

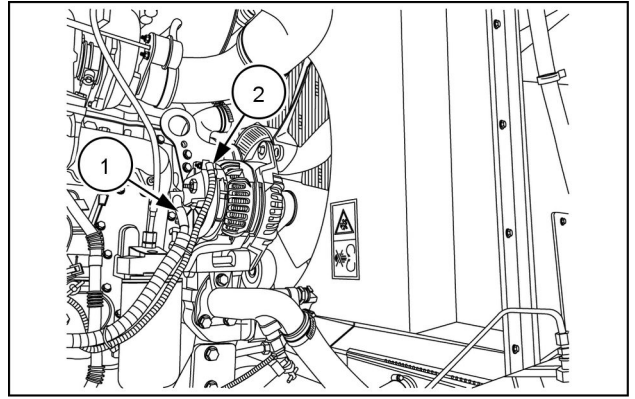

NHIL14WR01129AA 19

28. Disconnect the Engine Control Module (ECM) harness **(1)**. Remove the ECM harness and the A/C harness from the engine.

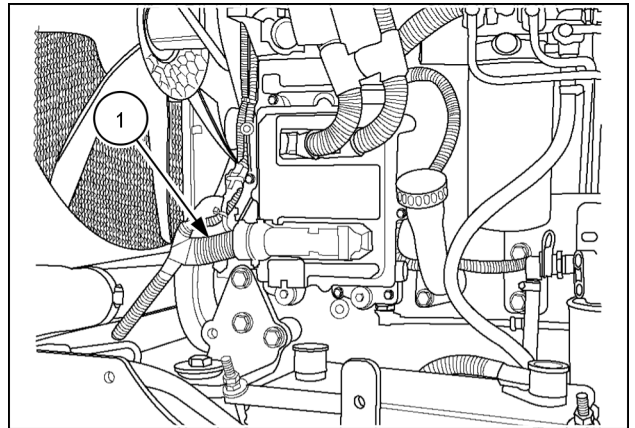

76075209 20

29. Remove plug **(1)** to drain oil from gear box.
30. With adequate support provided for the pumps, remove twelve flange bolts **(2)**.

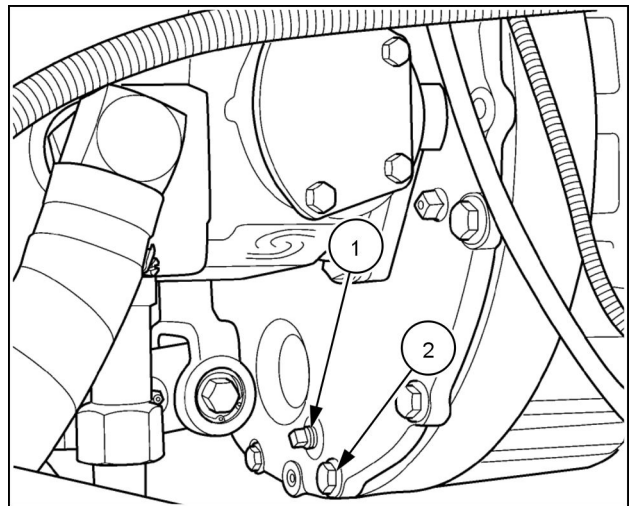

76113149 21

**Thank you very much
for your reading.**

**Please click here to buy
After you pay.**

**Then, you can
download the complete
manual instantly.
No waiting.**