

MDF0893A

T5030 - T5040 - T5050 - T5060 - T5070

TRACTORS SERVICE MANUAL

SECTIONS

GENERAL GUIDELINES	00
ENGINE	10
CLUTCH	18
TRANSMISSIONS	21
DRIVE LINES	23
FRONT MECHANICAL TRANSMISSION	25
REAR MECHANICAL TRANSMISSION	27
POWER TAKE-OFF	31
BRAKES	33
HYDRAULIC SYSTEMS	35
STEERING	41
AXLE AND WHEELS	44
CAB AIR CONDITIONING SYSTEM	50
ELECTRICAL SYSTEM	55
PLATFORM, CAB, BODYWORK	90

S E R V I C E

ENGINE R.I.**DANGER**

Lift and handle all heavy parts using suitable lifting equipment.

Make sure that assemblies or parts are supported by means of suitable slings and hooks. Ensure that no-one is in the vicinity of the load to be lifted.

**ATTENTION**

Use suitable tools to align the holes. NEVER USE FINGERS OR HANDS.

1. Remove the bonnet (1) as described, see section 90.
2. Disconnect the battery negative cable.
3. Drain the oil from the transmission-gearbox housing.
4. Remove the retaining bolts (1) and the guard (2) on the right-hand side of the fan, then remove the four bolts retaining the mechanical battery cut-out switch (1) from the guard.

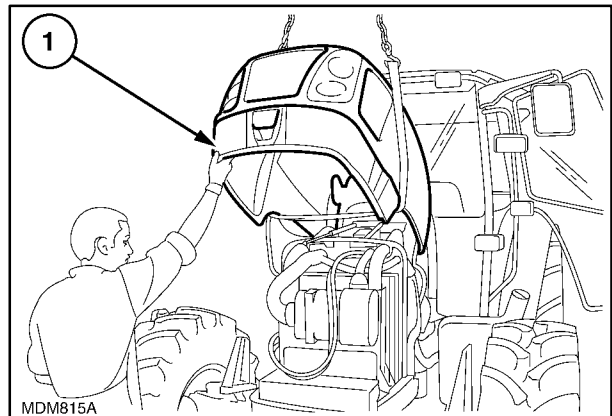

1

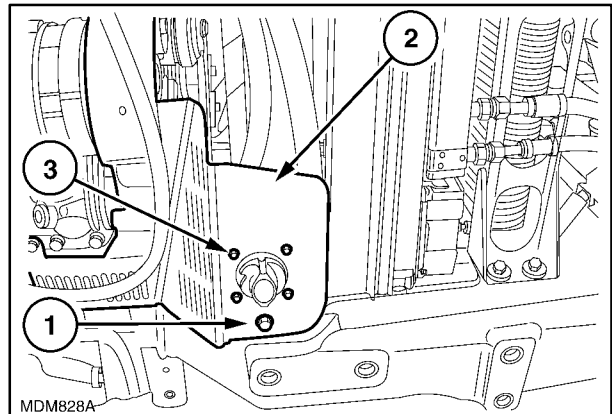

2

5. Unscrew the control unit memory fuse power cable (1) with the related positive cables (2) from the battery cut-out switch.

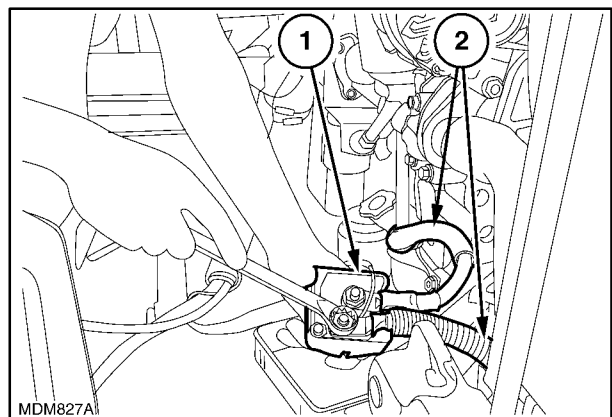

6. Detach the fitting (3) of the return pipe (2) for the coolant from the cab heater radiator connected to the underside of the coolant pump (1) and drain off the engine coolant.

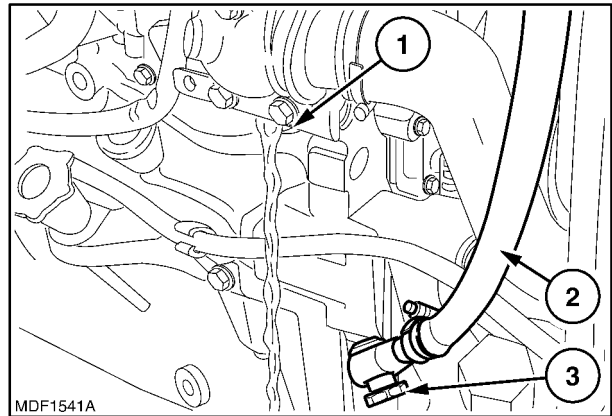

3

7. Remove the catch (2) and detach the toolbox (1).

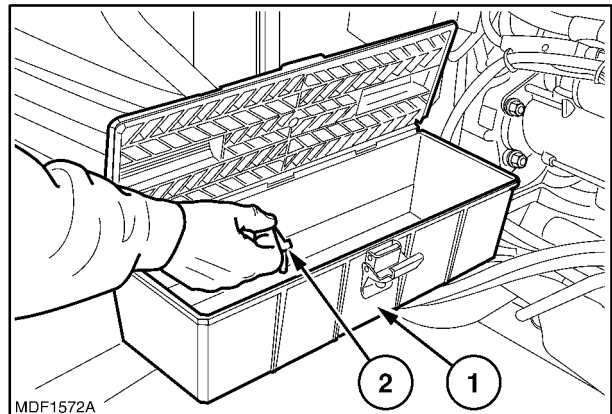

4

8. Remove the split pins, retaining pin and front ballast assembly (1) from the support.

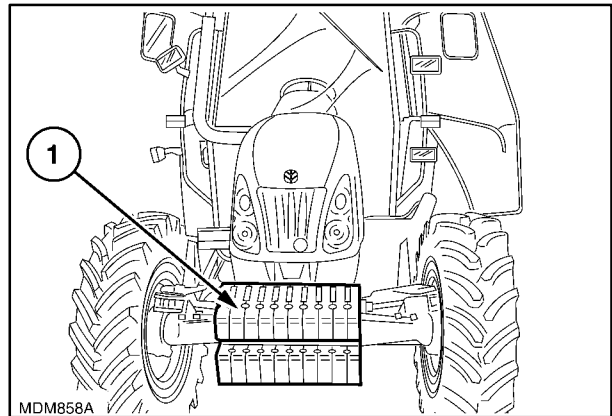

5

9. Unscrew the front central and rear retaining bolts on the front axle shaft guard, then remove the guard (1).

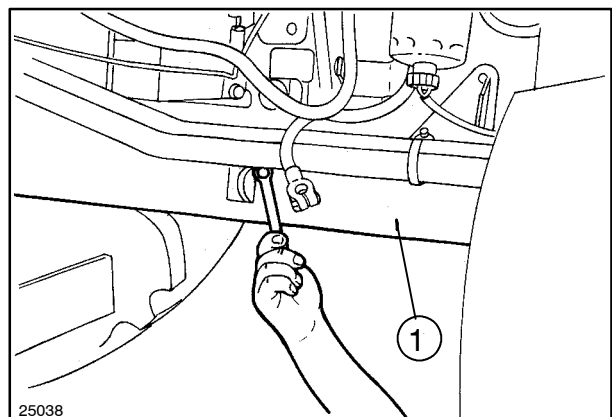

6

10. Remove the circlip (2) and move the front sleeve (1) in the direction indicated by the arrow until it is released from the groove on the front axle.

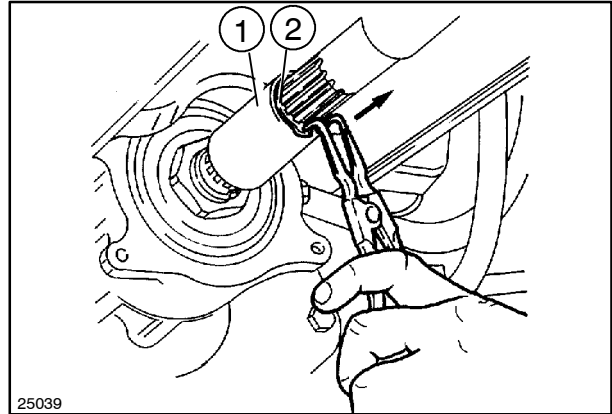

7

11. Remove the circlip (2) and move the rear sleeve (1) in the direction indicated by the arrow until it is released from the groove on the drive.

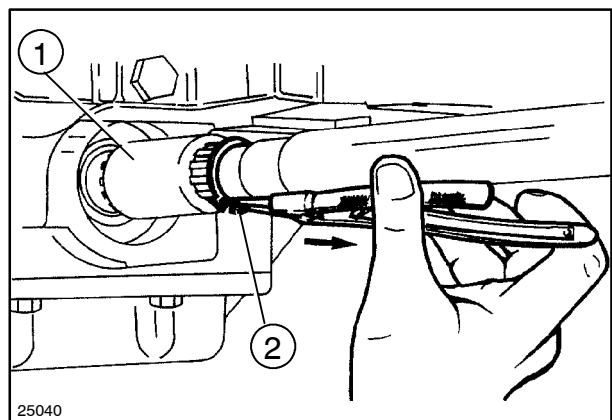

8

12. Remove the propeller shaft central support (1) retaining bolts and extract the shaft together with the support.

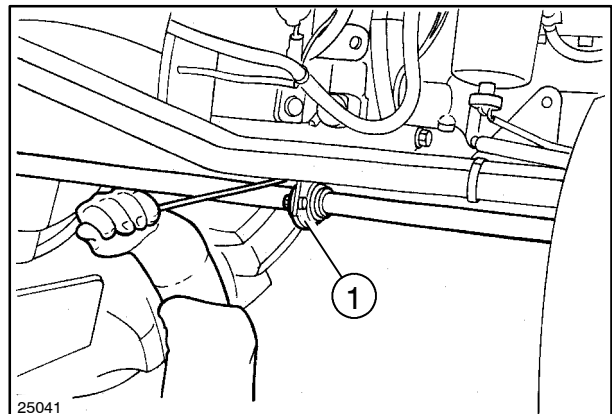

9

13. Remove the retaining bolts (1) of the draw pipe (2) of the lift pump.

On the same side of the machine, on the left, unscrew the underlying oil pipes and, if there are clamps on them screwed onto the frame, unscrew them to free the pipes from the frame.

- Unscrew the nozzle oil delivery pipe on the high-pressure pump.
- On the power steering pump, unscrew the oil hose delivering oil to the power steering control valve.
- Again on the left-hand side behind the connection between the clutch casing and engine, on the control valve of the gearbox (if there is a hydraulic gearbox) or on the services control valve, unscrew the delivery and return pipes to the cooler and the supply pipe to the control valve.
- Still in the area of the latter, unscrew the second part of the front differential lock pipe.

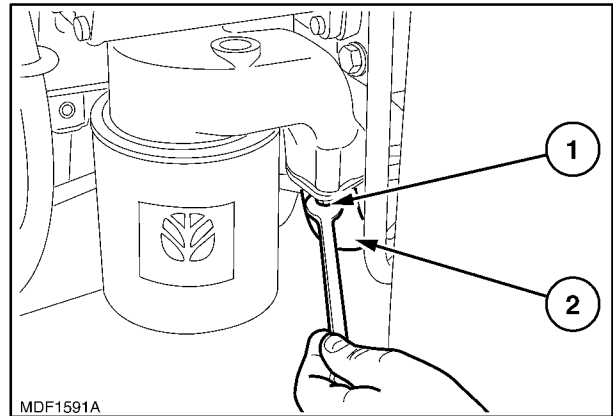

10

14. Remove the two metal clamps (2) and the rigid pipe (1) for drawing oil from the transmission via the pumps of the lift and power steering, remove the pipe.

On the same side of the machine, on the right, unscrew the underlying oil pipes and, if there are clamps on them screwed onto the frame, unscrew them to free the pipes from the frame.

- High pressure user supply pipe, remove the pipe.
- On the gearbox filter, remove the delivery to the gearbox control valve and extract the pipe, then remove the filter too.
- Again on the gearbox filter, remove the power steering outlet hose to the filter (in the case of the hydraulic transmission) or remove the supply pipe to the services control valve (in the case of the mechanical transmission) then remove the pipe.

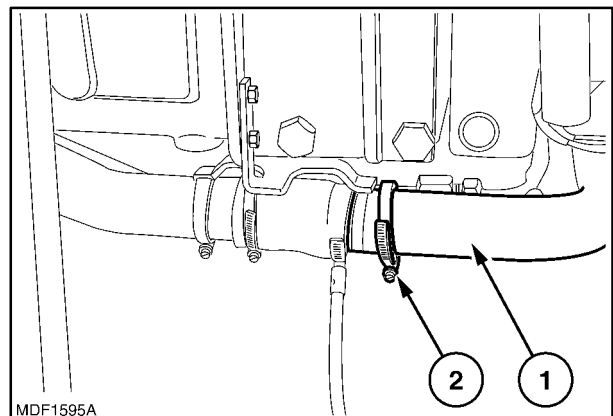

11

15. Extract the plastic fasteners (2) and detach the diesel recovery pipe (3) and delivery pipe (4) to the diesel pump (1).

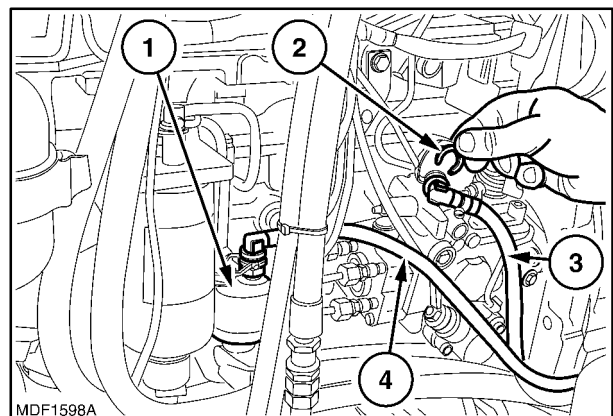

12

16. Disconnect the electrical connections (1) of the engine main cable from the cab cable.

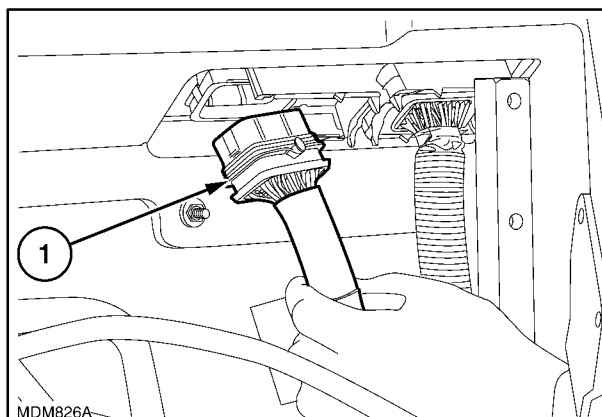

13

17. Disconnect all the electrical connections (1) located on the cab main cable and connect on the engine users.

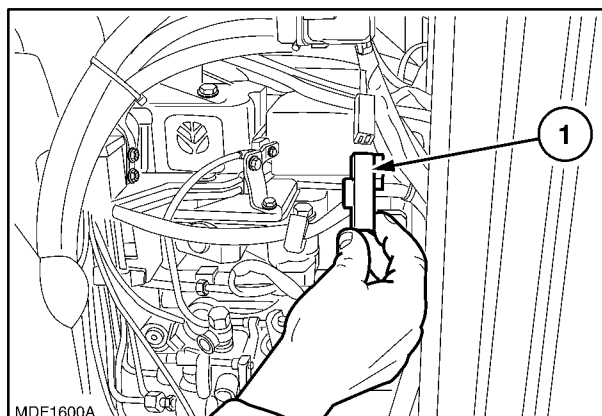

14

18. Disconnect the two power steering oil delivery and return hoses (1), remove the pipe.

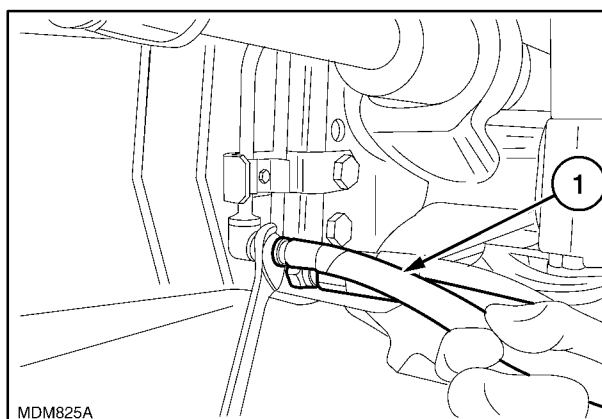

15

19. Remove the front differential lock union (1) and the hose (2) together with the pipe disconnected in the operation 13.

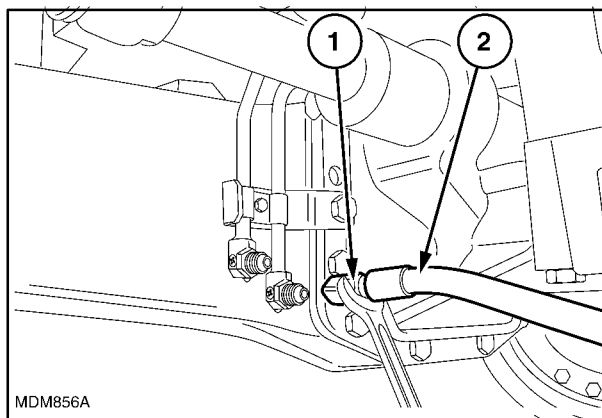

16

20. Remove the retaining clips (1) and detach the flexible cables governing the hand throttle (5) and pedal throttle (4).
21. Remove the retaining clip (3) and detach the throttle control tie-rod (2) connected to the injection pump.

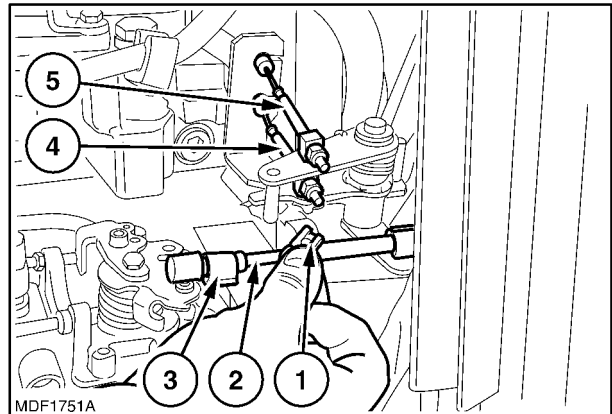

17

22. Detach the clamp (1) and the cab heater delivery pipe (2).

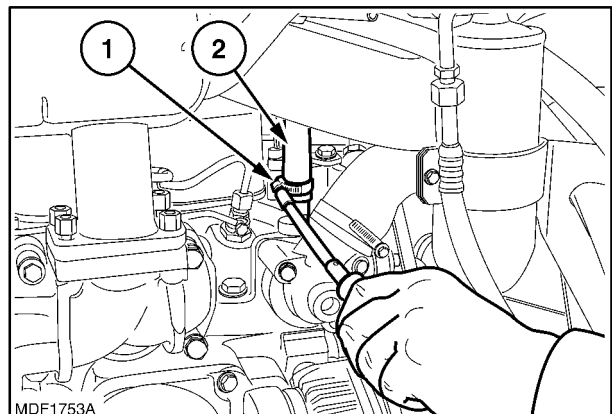

18

23. Take out the three exhaust silencer rear retaining bolts (1).

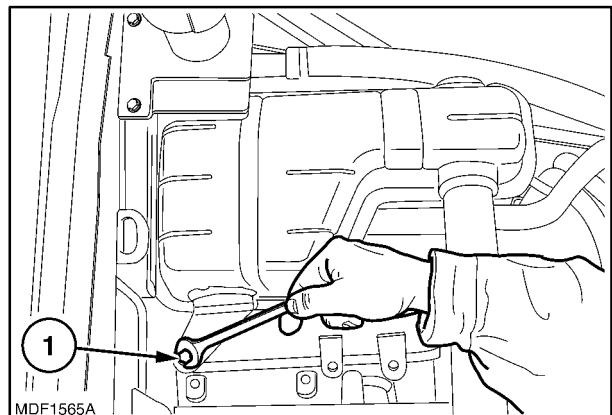

19

24. Remove the clamp (1), the air filter dust ejector pipe (2) and the four nuts (3) securing the silencer to the exhaust manifold.

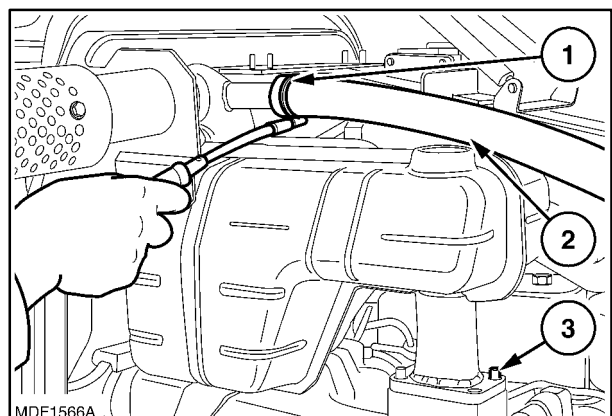

20

25. Remove the silencer (2) together with the exhaust pipe (1).

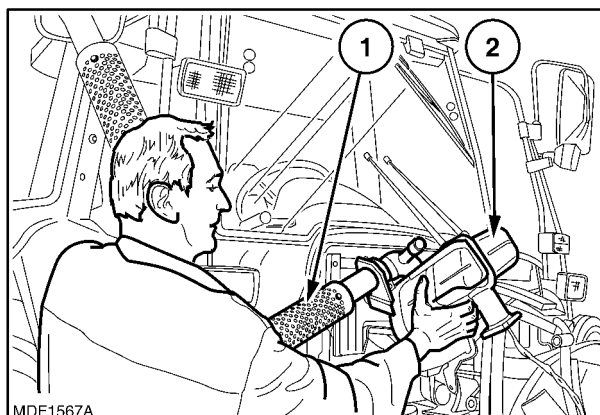

21

26. Remove the two clips (2) for retaining to the support (3) and the brake fluid reservoir (1).

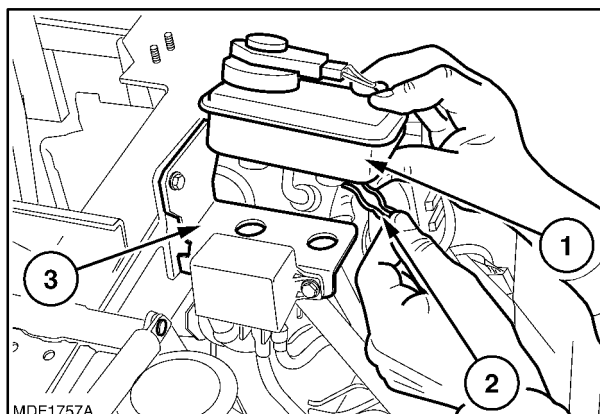

22

27. Remove the two retaining bolts (1) and the support (2) together with the relays (3) protecting the system.

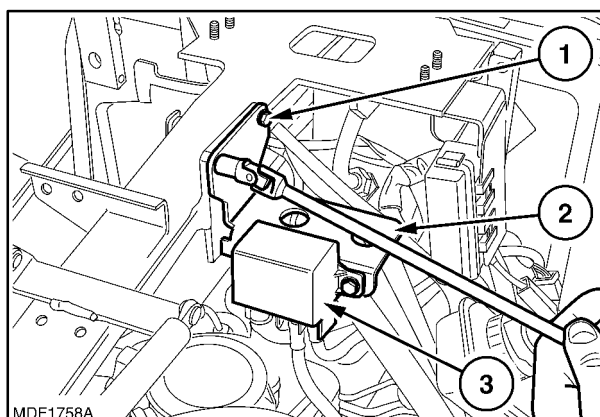

23

28. Remove the two retaining bolts (1) and the support together with the fuse-holder box (2).

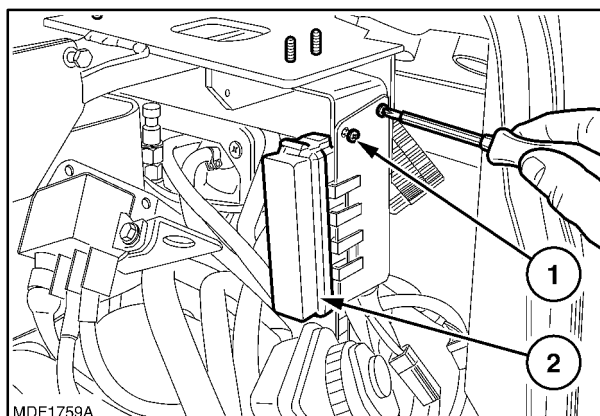

24

29. Remove the four rear retaining bolts (1) of the bonnet support (2).

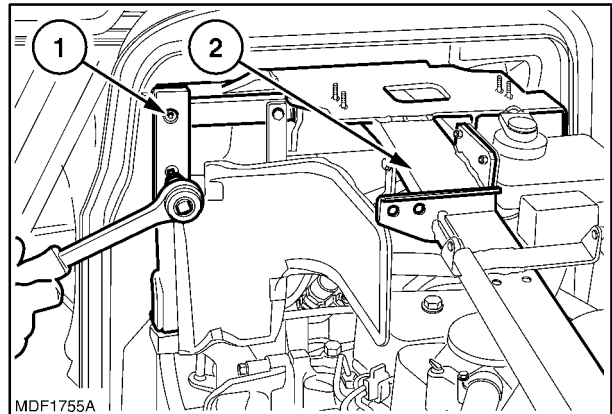

25

30. Remove the three front retaining bolts (1) of the bonnet support (2).

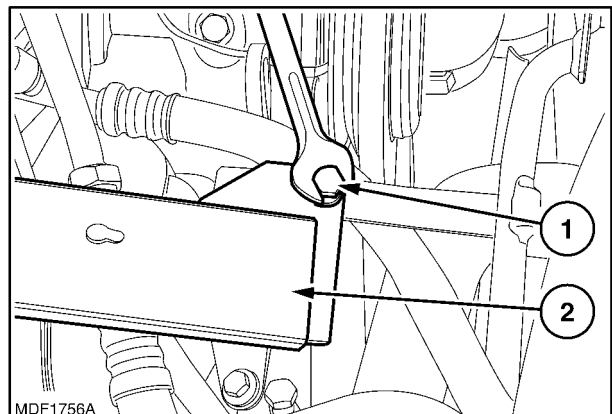

26

31. Detach the bonnet support (1).

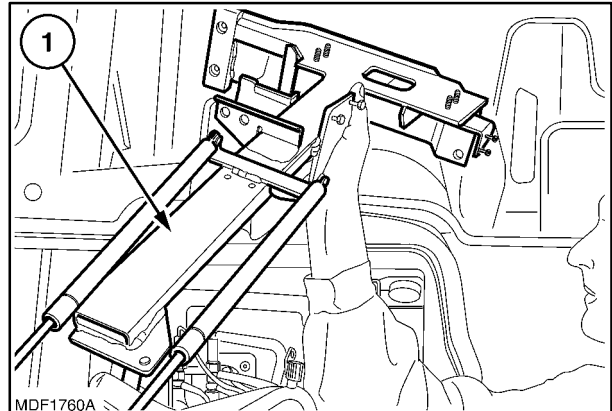

27

32. Disconnect the clogged filter sensor, loosen the clamps and detach the pipes on the air filter:

- air delivery to the turbo (1), (remember also to disconnect the pipe on the oil vapour recovery filter that will remain connected to the delivery pipe)
 - pneumatic braking compressor intake (2), (if installed)
 - ejector (3) then recovery it
- take out the screws (4), remove the air filter.

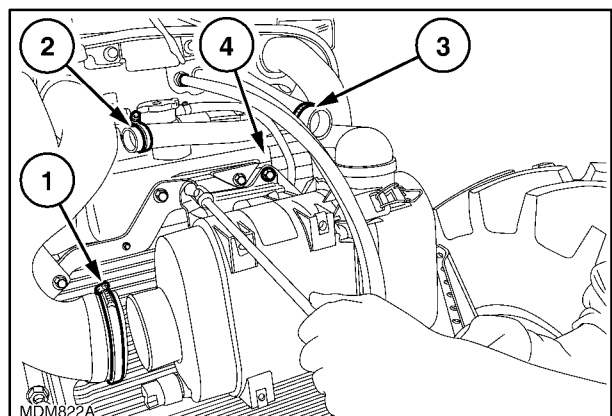

28

**Thank you very much
for your reading.**

**Please click here to buy
After you pay.**

**Then, you can
download the complete
manual instantly.
No waiting.**