

Fuel Injection Pump - Remove - Type 1 Engines and 9RM Engines

SMCS - 1251-011

Removal Procedure

Table 1

Required Tools			
Tool	Part Number	Part Description	Qty
A	173-9774	Bolt Remover ⁽¹⁾	1
B	9U-6198	Crankshaft Turning Tool	1
C	8S-2264	Puller Group	1
	8S-4712	Bolt	2

⁽¹⁾ The bolt remover is required in order to remove the tamper proof bolts on the access cover for the fuel injection pump.

Start By:

- A. Remove the water pump. Refer to Disassembly and Assembly, "Water Pump - Remove".
- B. Remove the fuel injection lines. Refer to Disassembly and Assembly, "Fuel Injection Lines - Remove and Install".

Note: For a complete description of Type 1 and Type 2 engines, refer to the Disassembly and Assembly, "Engine Design" topic.

NOTICE

Keep all parts clean from contaminants.

Contaminants may cause rapid wear and shortened component life.

NOTICE

Care must be taken to ensure that fluids are contained during performance of inspection, maintenance, testing, adjusting and repair of the product. Be prepared to collect the fluid with suitable containers before opening any compartment or disassembling any component containing fluids.

Refer to Special Publication, NENG2500, "Caterpillar Tools and Shop Products Guide" for tools and supplies suitable to collect and contain fluids on Caterpillar products.

Dispose of all fluids according to local regulations and mandates.

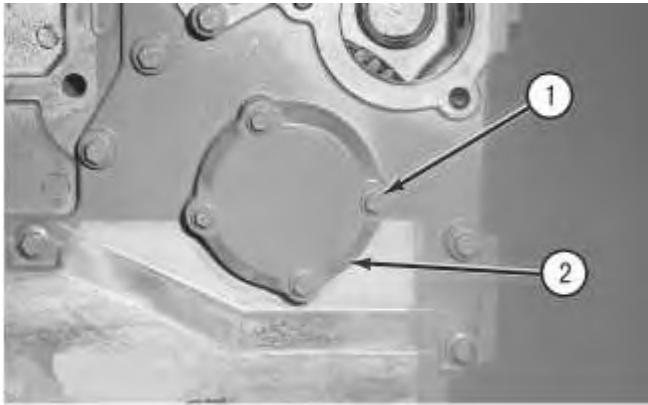

Illustration 1

g00545256

1. Remove four bolts (1) .

Note: Some engines may have four tamper proof bolts (1). Use Tool (A) in order to remove the tamper proof bolts.

2. Remove cover (2) .
-



Illustration 2

g00545258

3. Remove nut (3) and the lockwasher.

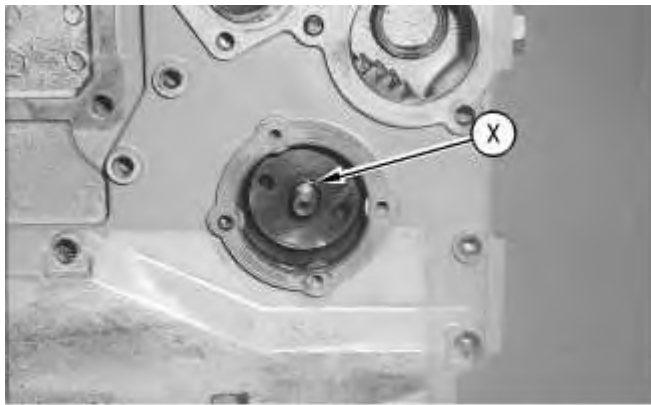

Illustration 3

g00571370

4. Use Tool (B) to rotate the crankshaft until keyway (X) is at 30 degrees from the vertical centerline.



Illustration 4

g00571373

5. Install Tool (C) .
6. Disengage the gear from the fuel injection pump.

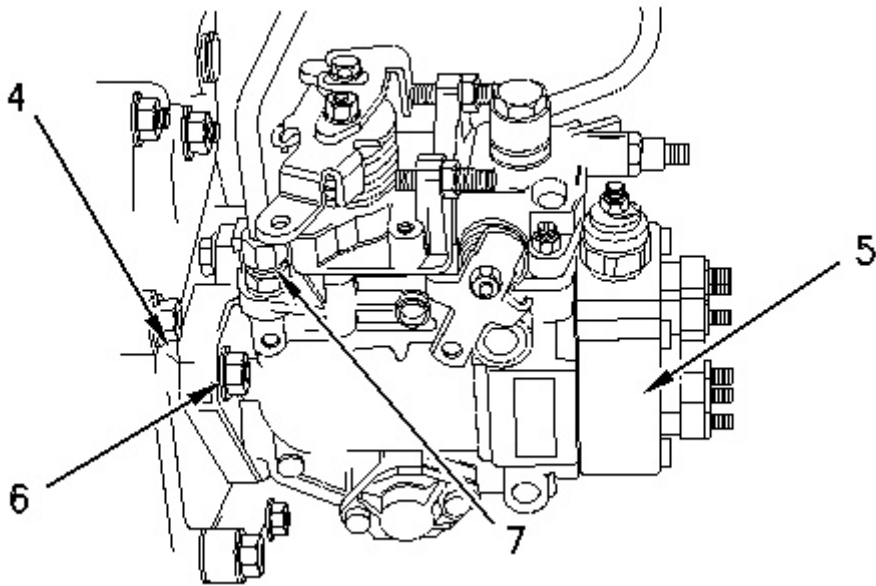

Illustration 5

g00545262

7. Disconnect hose (7) from the fuel injection pump.
8. Remove three nuts (6) that hold fuel injection pump (5) in position.
9. Remove fuel injection pump (5) and the gasket.

Note: Ensure that you do not lose the key when the fuel injection pump is removed. Also notice the position of marks (4) in order to ensure proper alignment of fuel injection pump (5) during installation.

**Thank you very much
for your reading.**

**Please click here to buy
After you pay.**

**Then, you can
download the complete
manual instantly.
No waiting.**