

Cylinder Head - Install

SMCS - 1100-012

Installation Procedure

Table 1

Required Tools			
Tool	Part Number	Part Description	Qty
A	138-7575	Link Bracket	2
	8T-4189	Bolt	2
	8T-4121	Hard Washer	2
B	-	Guide Bolt (M12 x 1.75 by 100 mm)	2
C	-	Straight Edge	1

1. Thoroughly clean the mating surfaces of the cylinder head and the cylinder block. Ensure that there is no debris in the cylinder bores, the coolant passages, or the lubricant passages.
 2. Inspect the mating surface of the cylinder head for distortion. Refer to Specifications, "Cylinder Head" for more information.
 3. Inspect the dowels for damage. If necessary, replace the dowels in the cylinder block.
-



Illustration 1

g02866543

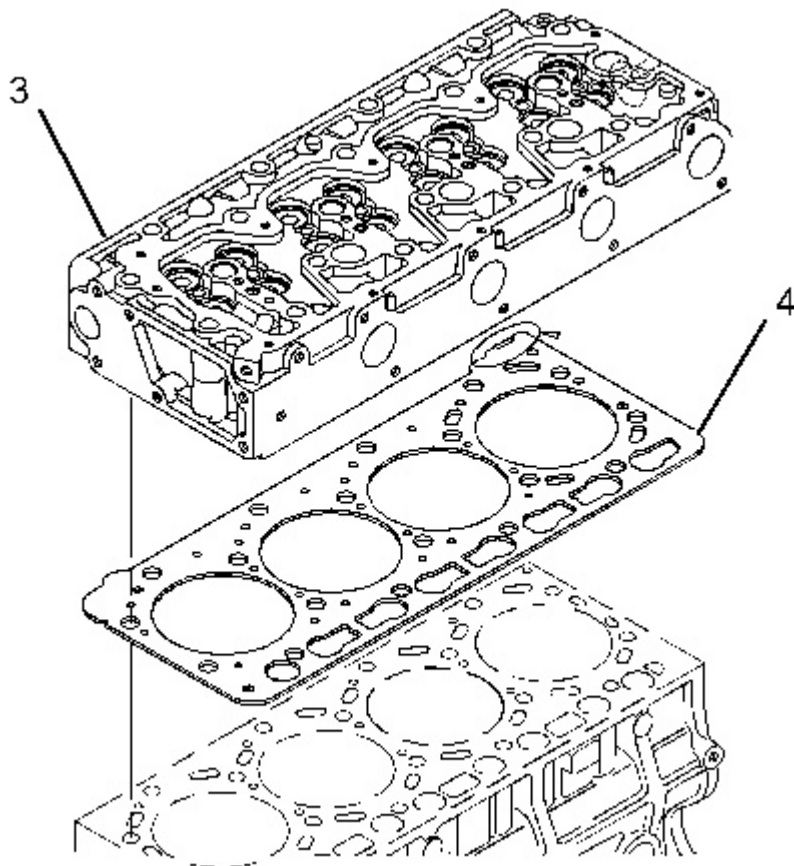

Illustration 2

g02866764

NOTICE

Place the cylinder head on a surface that will not scratch the face of the cylinder head.

4. Install a new gasket (4) . Refer to Table 2.
5. Use a suitable lifting device to install cylinder head (3) . The weight of cylinder head (3) is approximately 34 kg (75 lb).

Note: Ensure that the cylinder head and the gasket are aligned with the dowels on the engine block.



Illustration 3

g02866542

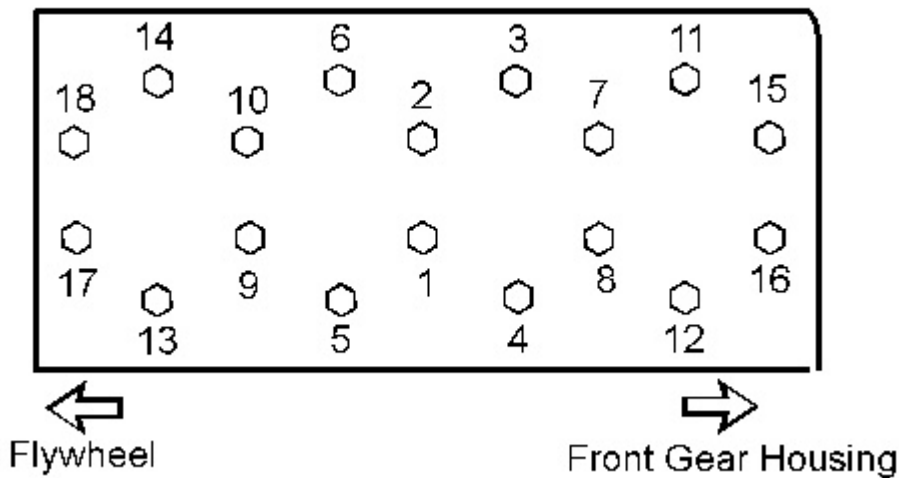

Illustration 4

g02866434

Cylinder head tightening sequence

6. Apply clean engine oil onto cylinder head bolts (2) . Install cylinder head bolts (2) . Gradually tighten cylinder head bolts (2) in the sequence that is shown in Illustration 4 to prevent distortion of the cylinder head.

7. Tighten cylinder head bolts (2) to a torque of $102.6 \pm 4.5 \text{ N}\cdot\text{m}$ ($75.7 \pm 3.3 \text{ lb ft}$).

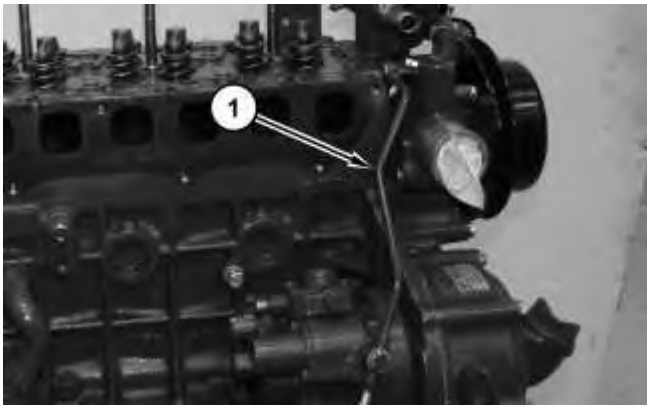

Illustration 5

g02866421

8. Install tube assembly (1) .

Cylinder Head Gasket

Table 2

Specifications for Cylinder Head Gasket Thickness			
Notch of Cylinder Head Gasket	Thickness of Cylinder Head Gasket		Piston head protrusion or recessing from the level of crankcase cylinder face (Average of four pistons).
	Before Tightening	After Tightening	
2 Notches	0.90 mm (0.035 inch)	0.80 mm (0.032 inch)	0.0700 to 0.0490 mm (0.00276 to 0.00193 inch)
1 Notch	1.00 mm (0.039 inch)	0.90 mm (0.035 inch)	0.0500 to 0.149 mm (0.00197 to 0.00586 inch)
Without notch	1.05 mm (0.041 inch)	0.95 mm (0.037 inch)	0.150 to 0.200 mm (0.00591 to 0.00787 inch)

End By:

- a. Install the rocker shaft and pushrods.
- b. Install the fuel injectors.
- c. Install inlet manifold.
- d. Install the exhaust manifold.

**Thank you very much
for your reading.**

**Please click here to buy
After you pay.**

**Then, you can
download the complete
manual instantly.
No waiting.**