

Illustration 2

g02797658

3. Carefully push piston (3) and the connecting rod from cylinder block (4) bore.
4. The connecting rod and the connecting rod cap should have an etched Number (X) on the side. The number on the connecting rod and the connecting rod cap must match. Ensure that the connecting rod and the connecting rod cap are marked for the correct location. If necessary, make a temporary mark on the connecting rod and the connecting rod cap in order to identify the cylinder number.

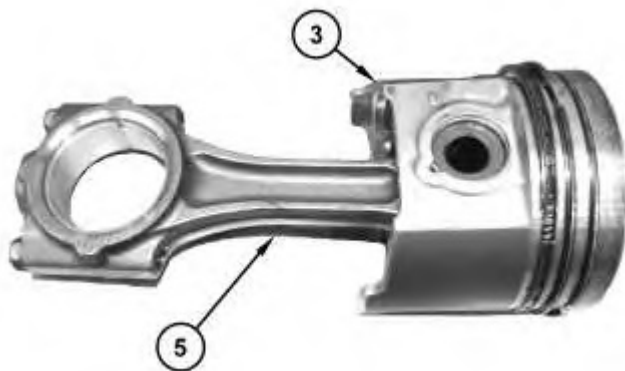

Illustration 3

g02797689

5. Remove piston (3) and connecting rod (5).

Installation Procedure

Table 1

Required Tools			
Tool	Part Number	Part Description	Qty
A	1U-6684	Piston Ring Compressor	1

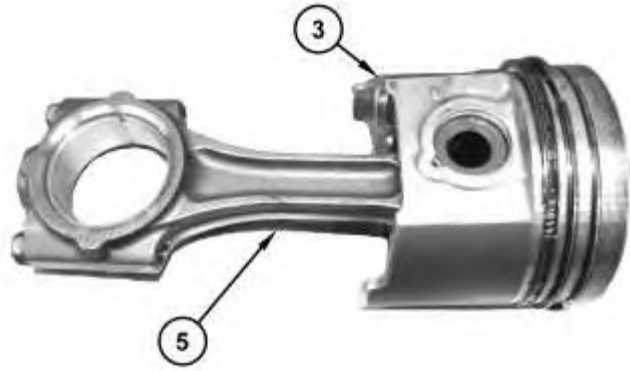

Illustration 4

g02797689

1. Inspect piston (3) and connecting rod assembly (5).
2. Apply clean engine oil to the cylinder bore, to the piston rings, to the outer surface of the piston and to the bearing shells.

Note: Install the bearing shells for the connecting rods dry when clearance checks are performed. Refer to Disassembly and Assembly, "Bearing Clearance - Check" for the correct procedure. Apply clean engine oil to the bearing shells for the connecting rods during final assembly.

Note: Ensure that the piston and the connecting rod assembly are installed in the correct cylinder.

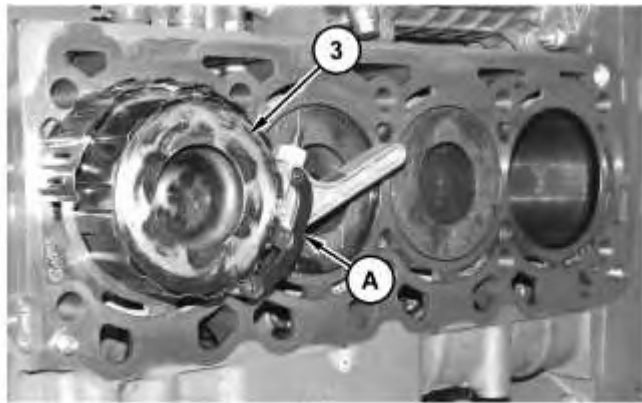

Illustration 5

g02797721

3. Install Tooling (A) onto piston (3).

Note: Ensure that Tooling (A) is installed correctly and that piston (3) can easily slide from the tool.

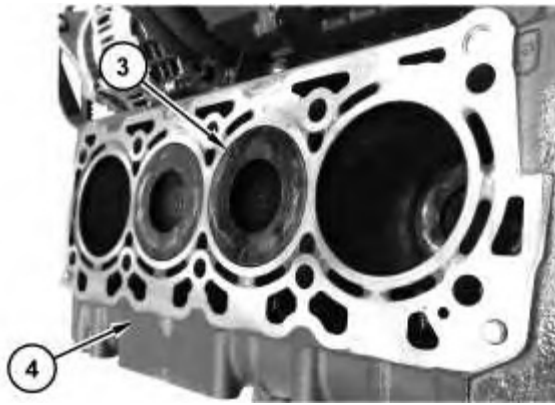

Illustration 6

g02797658

- Carefully push piston (3) and the connecting rod assembly into cylinder block (4) bore and onto the crankshaft pin.

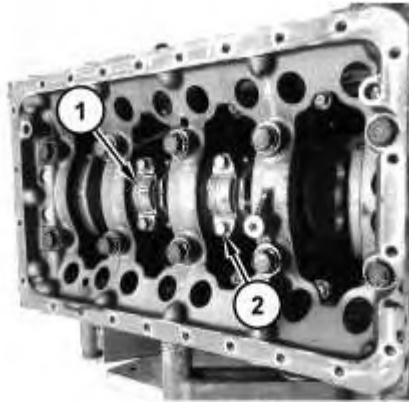

Illustration 7

g02797660

- Install connecting rod cap (1) onto the connecting rod .

Note: Ensure that etched Number (X) on connecting rod cap (1) matches etched Number (X) on the connecting rod. Ensure the correct orientation of the connecting rod cap. The locating tab for the upper bearing shell and the lower bearing shell should be on the same side.

Note: Do not reuse the old connecting rod bolts in order to secure the connecting rod cap.

- For the C3.3B apply clean engine oil to bolt threads and install new bolts (2) to the connecting rod. Tighten bolts (2) to a torque of 69 to 73 N·m (51 to 54 lb ft).
- For the C2.6 apply clean engine oil to bolt threads and install new bolts (2) to the connecting rod. Tighten bolts (2) to a torque of 45 ± 49 N·m (33 ± 36 lb ft).
- Ensure that the installed connecting rod assembly has side play. Rotate the crankshaft in order to ensure that there is no binding.
- Repeat Step 1 through Step 8 in order to install the remaining pistons and connecting rods.

End By:

**Thank you very much
for your reading.**

**Please click here to buy
After you pay.**

**Then, you can
download the complete
manual instantly.
No waiting.**