

1. Inspect fuel injection pump and governor (1).
2. Remove tube (2).

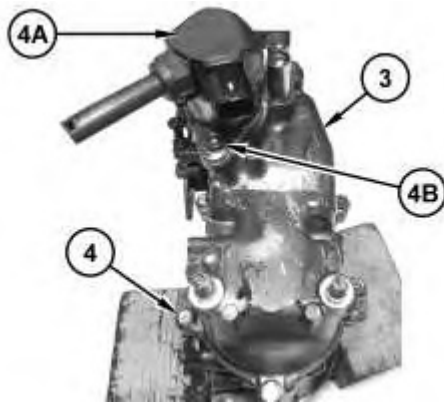

---

Illustration 2

g02805639

3. Use suitable blocking and position the fuel injection pump and governor. Remove bolts (4) and remove governor housing assembly (3).
4. Remove two bolts (4B) and remove stop solenoid (4A). Replace o-ring if necessary.

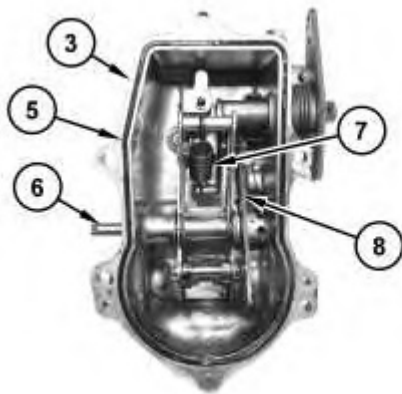

---

Illustration 3

g02805640

5. Remove and inspect O-ring seal (5) from governor housing assembly (3). If necessary, replace O-ring seal (5) with new.
  6. Remove shaft (6) and spring (7) from governor housing assembly (3). Remove governor lever (8).
-

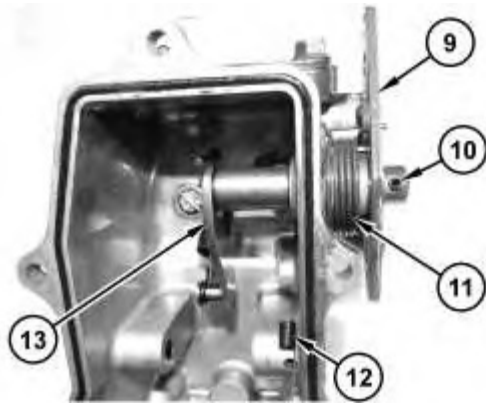

---

Illustration 4

g02805641

7. Remove pin (10) from governor lever assembly (12).
  8. Remove speed control lever (9) and spring (11) from governor lever assembly (12).
  9. Remove spring (13) and remove governor lever assembly (12) with the O-ring seals.
- 

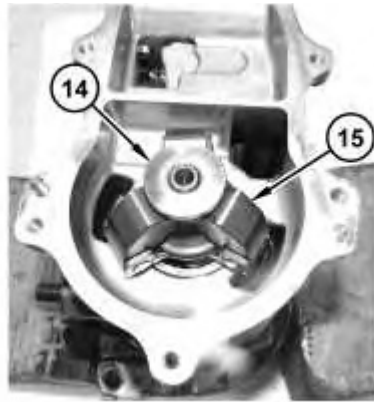

---

Illustration 5

g02805656

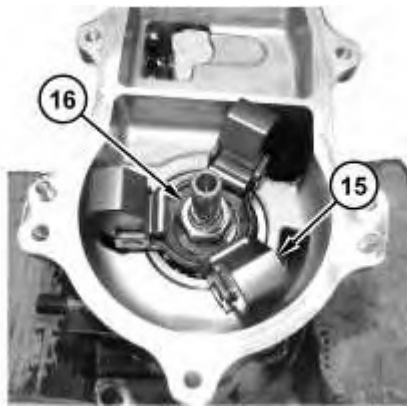

---

Illustration 6

g02805658

10. Remove governor sleeve (13) and nut (16). Remove governor weights (15).
-



---

Illustration 7

g02805660

---

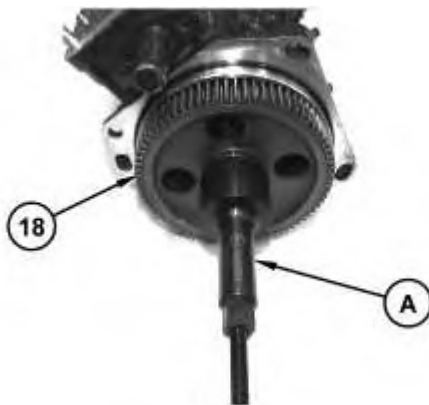

---

Illustration 8

g02805696

11. Remove nut (17) from gear (18).

**Note:** Nut (17) has reverse threads.

12. Use Tooling (A) to remove gear (18).

---

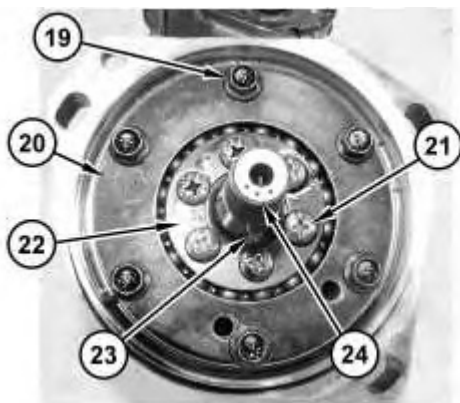

---

Illustration 9

g02805716

13. Remove bolts (19) and retaining plate (20).

14. Remove fuel camshaft (24) from the housing assembly.

15. Remove screws (21) and retaining plate (22). If necessary, replace key (23) with new.

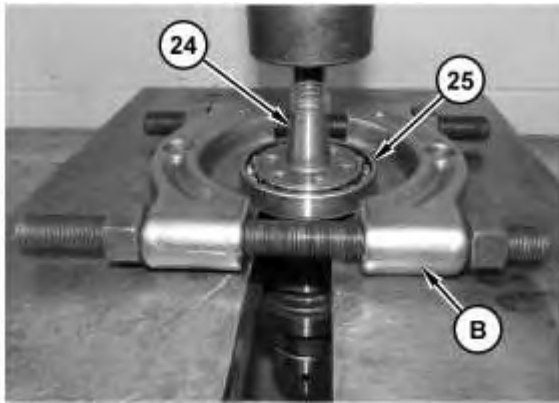

Illustration 10

g02805762

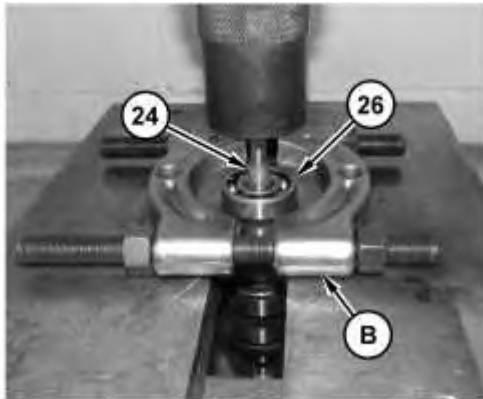

Illustration 11

g02805764

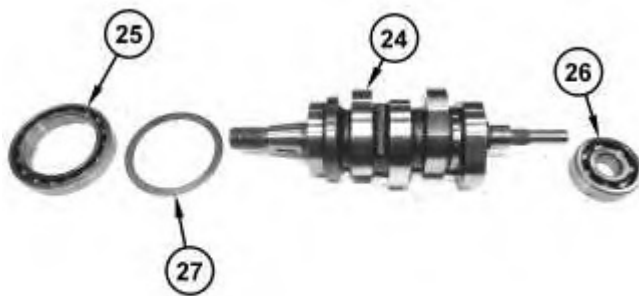

Illustration 12

g02805765

16. Use a suitable press and Tooling (B) to remove bearing (25) from fuel camshaft (24) and ring (27).

17. Use a suitable press and Tooling (B) to remove bearing (26) from fuel camshaft (24).

**Thank you very much  
for your reading.**

**Please click here to buy  
After you pay.**

**Then, you can  
download the complete  
manual instantly.  
No waiting.**