



SERVICE MANUAL

YZFR1Y(C)



HOW TO USE THIS MANUAL

This manual is intended as a handy, easy-to-read reference book for the mechanic. Comprehensive explanations of all installation, removal, disassembly, assembly, repair and check procedures are laid out with the individual steps in sequential order.

- The manual is divided into chapters and each chapter is divided into sections. The current section title “1” is shown at the top of each page.
- Sub-section titles “2” appear in smaller print than the section title.
- To help identify parts and clarify procedure steps, there are exploded diagrams “3” at the start of each removal and disassembly section.
- Numbers “4” are given in the order of the jobs in the exploded diagram. A number indicates a disassembly step.
- Symbols “5” indicate parts to be lubricated or replaced.
- Refer to “SYMBOLS”.
- A job instruction chart “6” accompanies the exploded diagram, providing the order of jobs, names of parts, notes in jobs, etc.
- Jobs “7” requiring more information (such as special tools and technical data) are described sequentially.

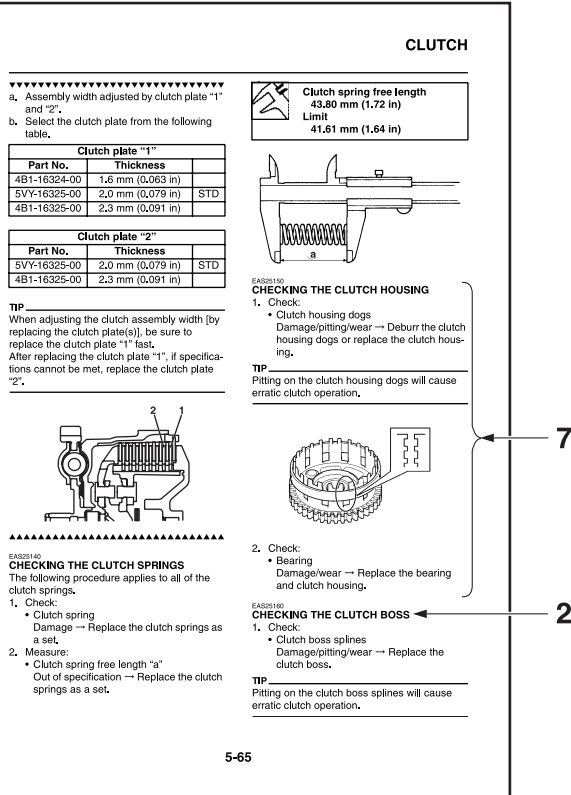
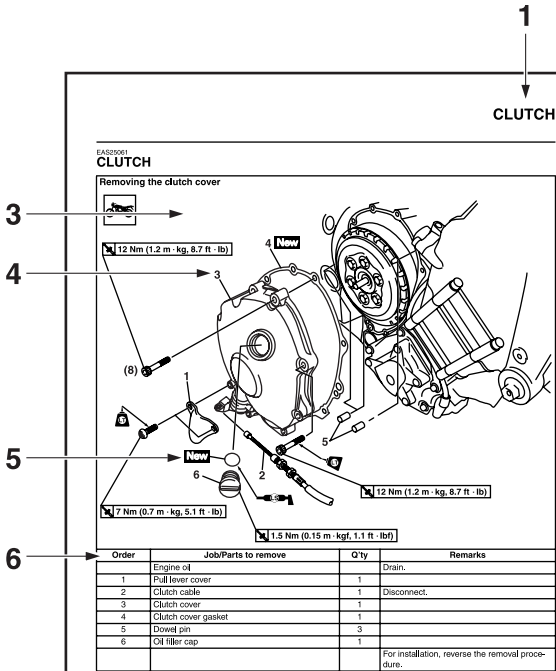

SYMBOLS

The following symbols are used in this manual for easier understanding.

TIP

The following symbols are not relevant to every vehicle.



















SYMBOL	DEFINITION	SYMBOL	DEFINITION
	Serviceable with engine mounted		Gear oil
	Filling fluid		Molybdenum disulfide oil
	Lubricant		Brake fluid
	Special tool		Wheel bearing grease
	Tightening torque		Lithium-soap-based grease
	Wear limit, clearance		Molybdenum disulfide grease
	Engine speed		Silicone grease
	Electrical data		Apply locking agent (LOC-TITE®).
	Engine oil		Replace the part with a new one.

TABLE OF CONTENTS

GENERAL INFORMATION	1
SPECIFICATIONS	2
PERIODIC CHECKS AND ADJUSTMENTS	3
CHASSIS	4
ENGINE	5
COOLING SYSTEM	6
FUEL SYSTEM	7
ELECTRICAL SYSTEM	8
TROUBLESHOOTING	9

GENERAL INFORMATION

IDENTIFICATION	1-1
VEHICLE IDENTIFICATION NUMBER.....	1-1
MODEL LABEL.....	1-1
FEATURES	1-2
OUTLINE OF THE FI SYSTEM	1-2
FI SYSTEM.....	1-3
YCC-T (Yamaha Chip Controlled Throttle)	
YCC-I (Yamaha Chip Controlled Intake)	1-4
INSTRUMENT FUNCTIONS	1-8
IMPORTANT INFORMATION	1-15
PREPARATION FOR REMOVAL AND DISASSEMBLY	1-15
REPLACEMENT PARTS.....	1-15
GASKETS, OIL SEALS AND O-RINGS.....	1-15
LOCK WASHERS/PLATES AND COTTER PINS	1-15
BEARINGS AND OIL SEALS	1-16
CIRCLIPS	1-16
CHECKING THE CONNECTIONS	1-17
HANDLING THE ELECTRONIC PARTS	1-18
SPECIAL TOOLS	1-19

EAS20130

IDENTIFICATION

EAS20140

VEHICLE IDENTIFICATION NUMBER

The vehicle identification number "1" is stamped into the right side of the steering head pipe.

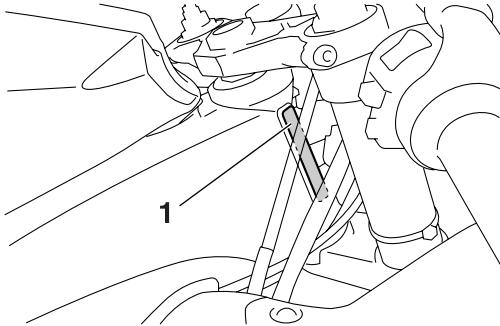

EAS20150

MODEL LABEL

The model label "1" is affixed to the seat rail reinforcement under the passenger seat. This information will be needed to order spare parts.

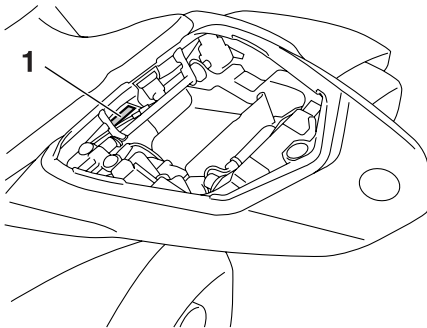

EAS20170

FEATURES

EAS30340

OUTLINE OF THE FI SYSTEM

The main function of a fuel supply system is to provide fuel to the combustion chamber at the optimum air-fuel ratio in accordance with the engine operating conditions and the atmospheric temperature. In the conventional carburetor system, the air-fuel ratio of the mixture that is supplied to the combustion chamber is created by the volume of the intake air and the fuel that is metered by the jet used in the respective carburetor.

Despite the same volume of intake air, the fuel volume requirement varies by the engine operating conditions, such as acceleration, deceleration, or operating under a heavy load. Carburetors that meter the fuel through the use of jets have been provided with various auxiliary devices, so that an optimum air-fuel ratio can be achieved to accommodate the constant changes in the operating conditions of the engine.

As the requirements for the engine to deliver more performance and cleaner exhaust gases increase, it becomes necessary to control the air-fuel ratio in a more precise and finely tuned manner. To accommodate this need, this model has adopted an electronically controlled fuel injection (FI) system, in place of the conventional carburetor system. This system can achieve an optimum air-fuel ratio required by the engine at all times by using a microprocessor that regulates the fuel injection volume according to the engine operating conditions detected by various sensors. The adoption of the FI system has resulted in a highly precise fuel supply, improved engine response, better fuel economy, and reduced exhaust emissions.

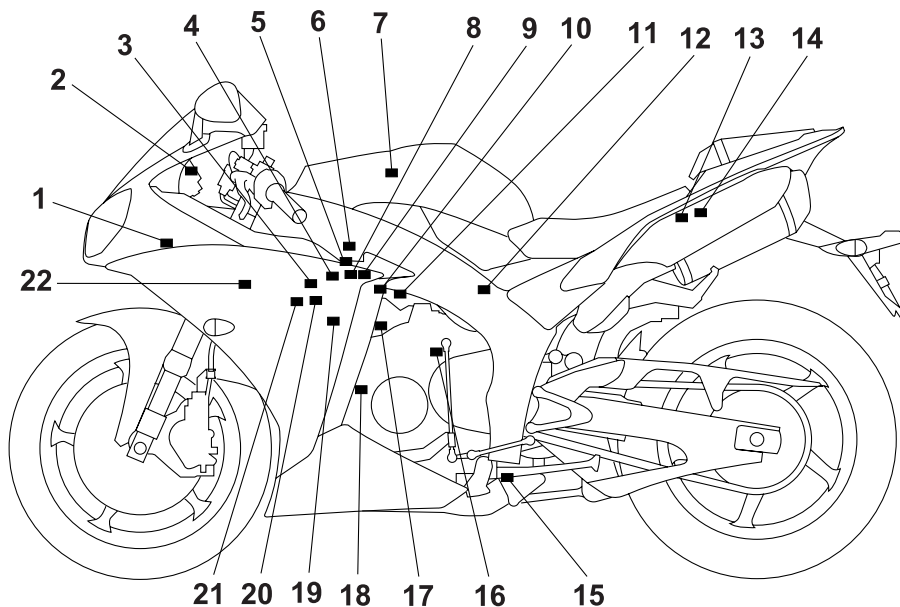

- | | |
|----------------------------------|------------------------------------|
| 1. Intake air temperature sensor | 13. Lean angle sensor |
| 2. Engine trouble warning light | 14. Relay unit (fuel pump relay) |
| 3. Air induction system solenoid | 15. O ₂ sensor |
| 4. Atmospheric pressure sensor | 16. Speed sensor |
| 5. Intake air pressure sensor | 17. Coolant temperature sensor |
| 6. Intake funnel servo motor | 18. Crankshaft position sensor |
| 7. Secondary injectors | 19. Spark plugs |
| 8. Throttle servo motor | 20. Ignition coils |
| 9. Throttle position sensor | 21. Cylinder identification sensor |
| 10. Accelerator position sensor | 22. ECU (engine control unit) |
| 11. Primary injectors | |
| 12. Fuel pump | |

**Thank you very much
for your reading.**

**Please click here and go
back to the website.**

**Then, you can
download the complete
manual instantly.**

No waiting.