

JOHN DEERE
WORLDWIDE COMMERCIAL & CONSUMER
EQUIPMENT DIVISION

Lawn Tractors
L100, L110, L118, L120 and L130

OMGX21647 K3

OPERATOR'S MANUAL



JOHN DEERE

North American Version
Litho in U.S.A.

INTRODUCTION

Thank You for Purchasing a John Deere Product

We appreciate having you as a customer and wish you many years of safe and satisfied use of your machine.

Using Your Operator's Manual

This manual is an important part of your machine and should remain with the machine when you sell it.

Reading your operator's manual will help you and others avoid personal injury or damage to the machine.

Information given in this manual will provide the operator with the safest and most effective use of the machine.

Knowing how to operate this machine safely and correctly will allow you to train others who may operate this machine.

If you have an attachment, use the safety and operating information in the attachment operator's manual along with the machine operator's manual to operate the attachment safely and correctly.

This manual and safety signs on your machine may also be available in other languages (see your authorized dealer to order).

Sections in your operator's manual are placed in a specific order to help you understand all the safety messages and learn the controls so you can operate this machine safely. You can also use this manual to answer any specific operating or servicing questions. A convenient index located at the end of this book will help you to find needed information quickly.

The machine shown in this manual may differ slightly from your machine, but will be similar enough to help you understand our instructions.

RIGHT-HAND and LEFT-HAND sides are determined by facing in the direction the machine will travel when going forward. When you see a broken line (-----), the item referred to is hidden from view.

Before delivering this machine, your dealer performed a predelivery inspection to ensure best performance.

Special Messages

Your manual contains special messages to bring attention to potential safety concerns, machine damage as well as helpful operating and servicing information. Please read all the information carefully to avoid injury and machine damage.



CAUTION: Avoid injury! This symbol and text highlight potential hazards or death to the operator or bystanders that may occur if the hazards or procedures are ignored.

IMPORTANT: Avoid damage! This text is used to tell the operator of actions or conditions that might result in damage to the machine.

NOTE: General information is given throughout the manual that may help the operator in the operation or service of the machine.

CALIFORNIA Proposition 65 Warning

▲ Warning: The Engine Exhaust from this product contains chemicals known to the State of California to cause cancer, birth defects or other reproductive harm.

Attachments for Your Machine

There's a John Deere attachment or kit to make your new machine perform more tasks or be more versatile, whether your machine is a lawn tractor or compact utility tractor or a utility vehicle.

You can check out the entire line of attachments for your machine at JohnDeere.com or ask your John Deere dealer. From aerators to electric lift kits to tillers, there's a John Deere attachment or kit to fill every need.

PRODUCT IDENTIFICATION

Record Identification Numbers

Lawn Tractors

L100, L110, L118, L120 and L130

PIN (010001-)

If you need to contact an Authorized Service Center for information on servicing, always provide the product model and identification numbers.

You will need to locate the model and serial number for the machine and for the engine of your machine and record the information in the spaces provided below.

DATE OF PURCHASE:

DEALER NAME:

DEALER PHONE:



MX7694Y

PRODUCT IDENTIFICATION NUMBER (A):

ENGINE SERIAL NUMBER (B):

MOWER DECK SERIAL NUMBER (C):

Register Your Product and Warranty Online

To register your product through the Internet, simply go to www.JohnDeereWarrantyRegistration.com. Completing the information, either online or with the product warranty card, will ensure the customer that their product receives all post sales service and important product information.

TABLE OF CONTENTS

Safety	1
Operating.....	10
Replacement Parts	29
Service Intervals.....	30
Service Lubrication.....	32
Service Engine	33
Service Transmission	40
Service Mower.....	41
Service Electrical.....	48
Service Miscellaneous.....	50
Troubleshooting	53
Storage	57
Assembly	59
Specifications	61
Warranty	65
Index.....	68

All information, illustrations and specifications in this manual are based on the latest information at the time of publication. The right is reserved to make changes at any time without notice.

COPYRIGHT© 2003
Deere & Co.
John Deere Worldwide Commercial and
Consumer Equipment Division
All rights reserved
Previous Editions
COPYRIGHT©

OMGX21647 K3 - English

SAFETY

Understanding The Machine Safety Labels



Safety-Alert Symbol

The machine safety labels shown in this section are placed in important areas on your machine to draw attention to potential safety hazards.

On your machine safety labels, the words DANGER, WARNING, and CAUTION are used with this safety-alert symbol. DANGER identifies the most serious hazards.

The operator's manual also explains any potential safety hazards whenever necessary in special safety messages that are identified with the word, CAUTION, and the safety-alert symbol.

DANGER: ROTATING BLADES CUT OFF ARMS AND LEGS



GX20207; MX7692

- Do not mow when children or others are around.
- Do not mow in reverse.
- Look down and behind before and while backing.
- Never carry children even with blades off.

WARNING: AVOID SERIOUS INJURY OR DEATH



GX20207; MX7692

- Drive up and down slopes, not across.
- Avoid sudden turns.
- If machine stops going uphill, stop blades and back down slowly.
- Keep safety devices (guards, shields, and switches) in place and working.
- Remove objects that could be thrown by blades.
- Read operator's manual.
- When leaving machine:
 - Stop engine
 - Set park brake
 - Remove key

DANGER - CAUTION: POISON

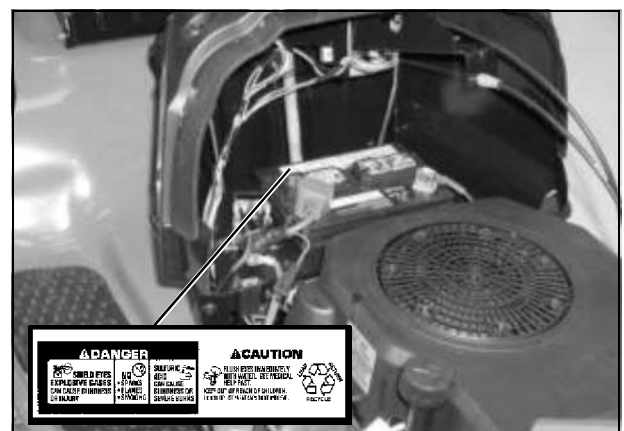

M128699; MX7686

Picture Note: Located on battery

SAFETY

- Shield eyes, explosive gases can cause blindness or injury.
- No sparks, flames, smoking.
- Sulfuric acid can cause blindness or severe burns.
- Flush eyes immediately with water. Get medical help fast.
- Keep out of reach of children.
- Do not tip.
- Keep vent caps tight and level.

DANGER: ROTATING BLADE-THROWN OBJECTS

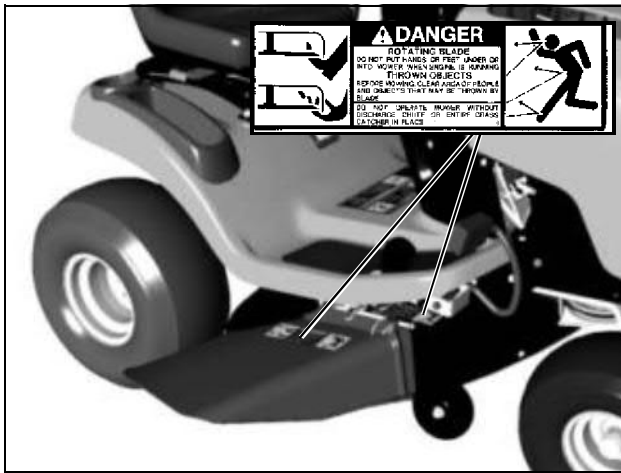

MX7693; M89504

Picture Note: Two on right side of deck. 42 (3 in 1) shown.

- Rotating blade.
- Do not put hands or feet under or into mower when engine is running.
- Thrown objects.
- Before mowing, clear area of objects that may be thrown by blade.
- Do not operate mower without discharge chute or entire grass catcher in place.

DANGER: ROTATING BLADE



MX7694Y; M118610

Picture Note: Located on left side of deck. 42 (3 in 1) shown.

- Do not put hands or feet under or into mower when engine is running.

Warning



MX7565; MX4878

Picture Note: This label appears on Briggs and Stratton engines only. It may be in a different location on your engine.

- Read and follow Operating Instructions before running engine.
- Gasoline is flammable. Allow engine to cool at least 2 minutes before refueling.
- Engines emit carbon monoxide, DO NOT run in enclosed area.

Emission Control System Certification Label

NOTE: Tampering with emission controls and

SAFETY

components by unauthorized personnel may result in severe fines or penalties. Emission controls and components can only be adjusted by EPA and/or CARB authorized service centers. Contact your John Deere Commercial and Consumer Equipment Retailer concerning emission controls and component questions.

The presence of an emissions label signifies that the engine has been certified with the United States Environmental Protection Agency (EPA) and/or California Air Resources Board (CARB).

The emissions warranty applies only to those engines marketed by John Deere that have been certified by the EPA and/or CARB; and used in the United States and Canada in off-road mobile equipment.

Emission Compliance Period

If your engine has the emission compliance category listed on the emission control system certification or air index label, this indicates the number of operating hours for which the engine has been certified to meet EPA and/or CARB emission requirements. The following table provides the engine compliance period in hours associated with the category found on the certification label.

Agency	Category	Hours
EPA	C	250
EPA	B	500
EPA	A	1000
CARB	Moderate	125
CARB	Intermediate	250
CARB	Extended	500

Certification

Your mower has been certified by an independent laboratory for compliance with American National Standard B-71.1, "Safety Specifications" for Power Lawn Mowers, Lawn and Garden Tractors, and Lawn Tractors.

Canadian Electromagnetic Compatibility (EMC) Compliance

For machines sold in Canada, this spark ignition system complies with Canadian ICES-002.

Operating Safely

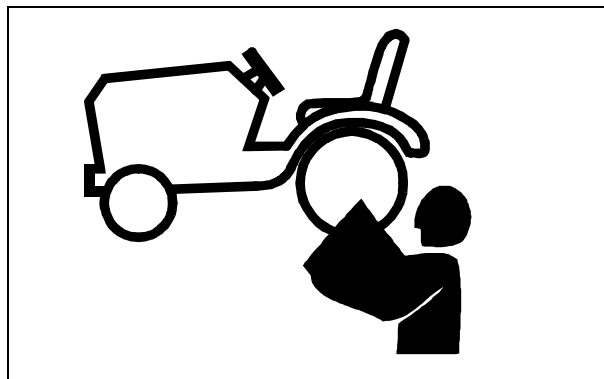

- Read, understand and follow all instructions in the manual, on the machine and on the safety video before starting.
- Only allow responsible adults, who are familiar with the instructions to operate the machine. Local restrictions may restrict the age of the operator.
- Be thoroughly familiar with the controls and the proper use of the machine before starting.
- Inspect machine before you operate. Be sure hardware is tight. Repair or replace damaged, badly worn, or missing parts. Replace faulty silencers. Be sure guards and shields are in good condition and fastened in place. Make any necessary adjustments before you operate.
- Before using, always visually inspect to see that the blades, blade bolts and the mower assembly are not worn and damaged. Replace worn and damaged blades and bolts in sets to preserve balance.
- Be sure all drives are in neutral and parking brake is locked before starting engine. Only start engine from the operator's position.
- Do not change the engine governor settings or overspeed the engine. Operating the engine at excessive speed can increase the hazard of personal injury.
- Do not operate mower without discharge chute or entire grass catcher in place. Never operate with the discharge deflector raised, removed, or altered, unless using a grass catcher.
- Check brake action before you operate. Adjust or service brakes as necessary.
- Stop machine if anyone enters the area.
- If you hit an object or if abnormal vibration occurs, stop the machine and inspect it. Make repairs before you operate. Keep machine and attachments properly maintained and in good working order.
- Be aware of the mower discharge direction and make sure that no one is in the path of the discharge direction.

SAFETY

- Do not leave machine unattended when it is running.
- Only operate during daylight or with good artificial light.
- Slow down and be careful of traffic when operating near or crossing roadways. Stop blades before crossing roads or sidewalks. Use care when approaching blind corners, shrubs, trees, or other objects that may obscure vision.
- Do not operate machine if you are under the influence of drugs or alcohol.
- Use only accessories and attachments approved by the manufacturer of the machine. Keep safety labels visible when installing accessories and attachments.
- Older adults are involved in a large percentage of riding mower accidents involving injury. These operators should evaluate their ability to operate a mower safely enough to protect the operator and others from serious injury.
- Do not wear radio or music headphones. Safe service and operation requires your full attention.
- Disengage drive to attachments when transporting or not in use.
- Reduce the throttle setting during engine run-out and, if the engine is provided with a fuel shut-off valve, turn the fuel off at the conclusion of mowing.
- When machine is left unattended, stored, or parked, lower the mower deck unless a positive mechanical lock is used.

Using a Spark Arrestor

The engine in this machine is not equipped with a spark arrestor muffler. It is a violation of California Public Resource Code Section 4442 to use or operate this engine on or near any forest-covered, brush-covered or grass-covered land unless the exhaust system is equipped with a spark arrestor meeting any applicable local or state laws. Other states or federal areas may have similar laws.

A spark arrestor for your machine may be available from your authorized dealer. An installed spark arrestor must be maintained in good working order by the operator.

Checking Mowing Area

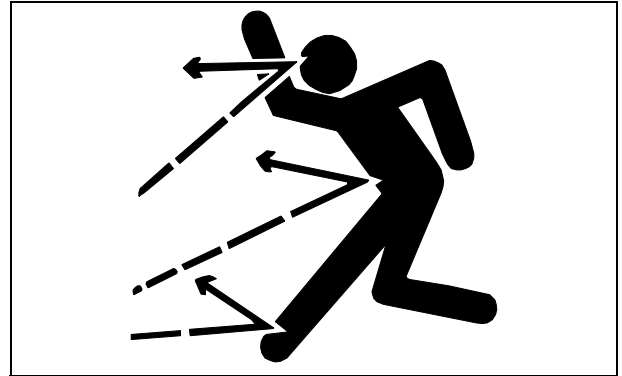

- Clear mowing area of objects that might be thrown. Keep people and pets out of mowing area.
- Low-hanging branches and similar obstacles can injure the operator or interfere with mowing operation. Before mowing, identify potential obstacles such as low-hanging branches, and trim or remove those obstacles.
- Study mowing area. Set up a safe mowing pattern. Do not mow where traction or stability is doubtful.
- Test drive area with mower lowered but not running. Slow down when you travel over rough ground.

Parking Safely

1. Stop machine on a level surface, not on a slope.
2. Disengage mower blades or any other attachments.
3. Lower attachments to the ground.
4. Lock the park brake.
5. Stop the engine.
6. Remove the key.
7. Wait for engine and all moving parts to stop before you leave the operator's seat.
8. Close fuel shut-off valve, if your machine is equipped.
9. Disconnect the negative battery cable or remove the spark plug wire (for gasoline engines) before servicing the machine.

SAFETY

Rotating Blades are Dangerous

HELP PREVENT SERIOUS OR FATAL ACCIDENTS:

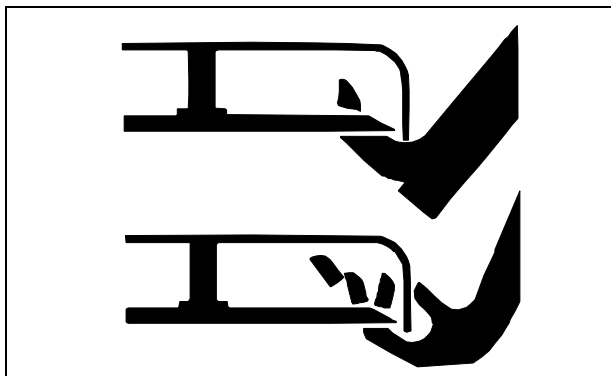

- Rotating blades can cut off arms and legs, and throw objects. Failure to observe safety instructions could result in serious injury or death.
- Keep hands, feet and clothing away from mower deck when engine is running.
- Be alert at all times, drive forward and in reverse carefully. People, especially children can move quickly into the mowing area before you know it.
- Do not mow in reverse.
- Shut off blades when you are not mowing.
- Park machine safely before leaving the operator's station for any reason including emptying the catchers or unplugging the chute.
- The mower blades should stop in approximately five seconds when the mower is disengaged. If you believe that your blades may not be stopping in that period of time, take your machine to your authorized dealer where they can safely check and service your machine.

Protect Children

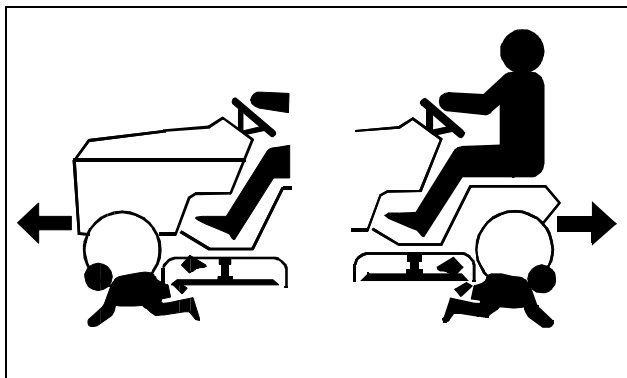

- Death or serious injury can occur when young children

associate having fun with a lawn mowing machine simply because someone has given them a ride on a machine.

- Young children are attracted to lawn mowing machines and mowing activities. They don't understand the dangers of rotating blades or the fact that the operator is unaware of their presence.
- Tragic accidents with children can occur if the operator is not alert to the presence of children, especially when a child approaches a machine from behind. Before backing up, stop mower blades and look down and behind the machine carefully, especially for children.
- Never carry children on a machine or attachment, even with the blades off. Do not tow children in a cart or trailer. They can fall off and be seriously injured or interfere with safe machine operation.
- Never use the machine as a recreational vehicle or to entertain children.
- Do not let children or an untrained person operate the machine. Instruct all operators not to give children a ride on the machine or in an attachment.
- Keep children indoors, out of the mowing area, and under the watchful eye of a responsible adult when a mower is being operated.
- Stay alert to the presence of children. Never assume that children will remain where you last saw them. Turn the machine off if a child enters the work area.

Avoid Tipping

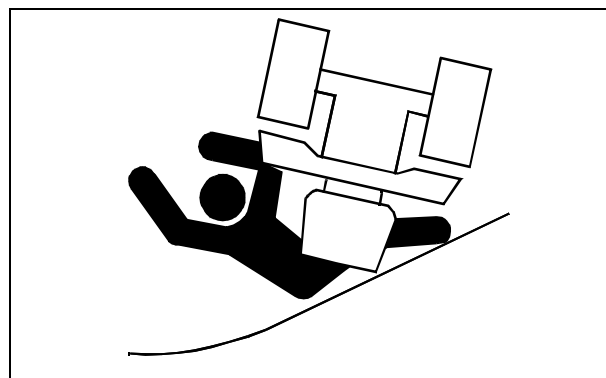

- Slopes are a major factor related to loss-of-control and tip-over accidents, which can result in severe injury or death. All slopes require extra caution. If you cannot back up the slope or if you feel uneasy on it, do not mow it.
- Drive up and down a hill - not across.
- Do not mow or operate on slopes you cannot back up.
- Keep all movement on slopes slow and gradual. Do not make sudden changes in speed or direction.

SAFETY

- Use a slow speed when operating on a slope. Choose a low gear or speed so that you will not have to stop or shift while on the slope.
- Tires may lose traction on slopes even though the brakes are functioning properly.
- Do not turn on slopes unless necessary. Turn slowly and turn downhill. Do not shift to neutral and coast downhill.
- Stay alert for holes and other hidden hazards in the terrain. Uneven terrain could overturn the machine. Tall grass can hide obstacles.
- Keep away from drop-offs, ditches and embankments. The machine could suddenly turn over if a wheel is over the edge of a cliff or ditch, or if an edge caves in.
- Use extra care with grass catchers or other attachments. These can change the stability of the machine. Do not use grass catcher on steep slopes.
- Follow the manufacturer's recommendations for wheel weights or counterweights for added stability when operating on slopes or using front or rear mounted attachments. Remove weights when not required.
- Do not stop when going up hill or down hill. If machine stops going up hill or tires lose traction, disengage mower blades and back down slowly.
- Operating machine when grass is wet can cause reduced traction and sliding.
- Do not try to stabilize the machine by putting your foot on the ground.

Keep Riders Off



MIF

- Only allow the operator on the machine. Keep riders off.
- Riders on the machine or attachment may be struck by foreign objects or thrown off the machine causing serious injury.
- Riders obstruct the operator's view resulting in the

machine being operated in an unsafe manner.

Towing Loads Safely

- Stopping distance increases with speed and weight of towed load. Travel slowly and allow extra time and distance to stop.
- Total towed weight must not exceed combined weight of pulling machine, ballast and operator. Use counterweights or wheel weights as described in the attachment or pulling machine operator manual.
- Excessive towed load can cause loss of traction and loss of control on slopes. Reduce towed weight when operating on slopes.
- Never allow children or others in or on towed equipment.
- Use only approved hitches. Tow only with a machine that has a hitch designed for towing. Do not attach towed equipment except at the approved hitch point.
- Follow the manufacturer's recommendations for weight limits for towed equipment and towing on slopes.
- If you cannot back up a slope with a towed load, the slope is too steep to operate on with the towed load. Reduce the towed load or do not operate.
- Do not turn sharply. Use additional caution when turning or operating under adverse surface conditions. Use care when reversing.
- Do not shift to neutral and coast downhill.

Wear Appropriate Clothing

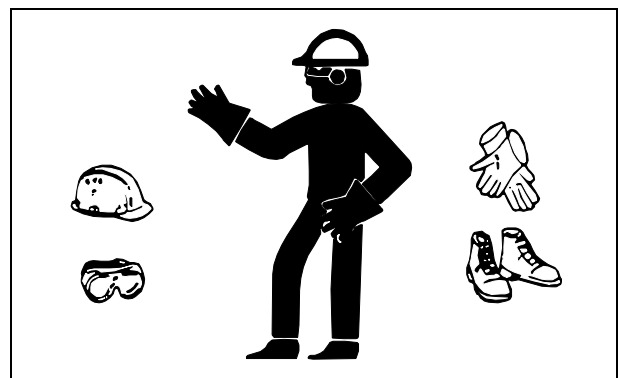

- Always wear safety goggles or safety glasses with side shields when operating the machine.
- Wear close fitting clothing and safety equipment appropriate for the job.
- While mowing, always wear substantial footwear and long trousers. Do not operate the equipment when barefoot

SAFETY

or wearing open sandals.

- Wear a suitable protective device such as earplugs. Loud noise can cause impairment or loss of hearing.

Driving Safely on Public Roads

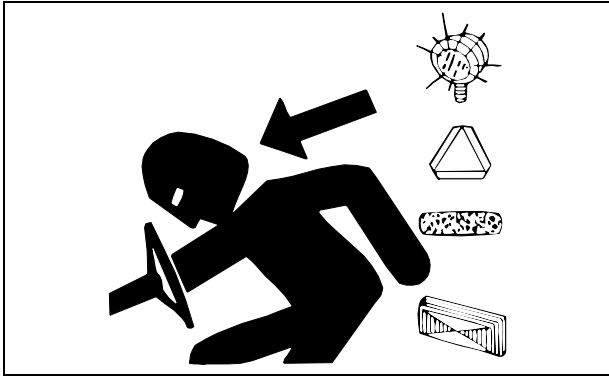

Avoid personal injury or death resulting from a collision with another vehicle on public roads:

- Use safety lights and devices. Slow moving machines when driven on public roads are hard to see, especially at night.
- Whenever driving on public roads, use flashing warning lights and turn signals according to local regulations. Extra flashing warning lights may need to be installed.

Practice Safe Maintenance



MIF

- Only qualified, trained adults should service this machine.
- Understand service procedure before doing work. Keep area clean and dry.
- Do not operate the engine in a confined space where dangerous carbon monoxide fumes can collect.
- Never lubricate, service, or adjust machine while it is

moving. Wait for all movement to stop on machine before adjusting, cleaning or repairing.

- Keep safety devices in place and in working condition. Keep hardware tight.
- On multi-bladed machines, take care as rotating one blade can cause other blades to rotate.
- Keep hands, feet, clothing, jewelry, and long hair away from any moving parts, to prevent them from getting caught.
- Lower attachments to the ground before cleaning or servicing machine. Disengage all power and stop the engine. Lock park brake and remove the key. Let machine cool.
- Disconnect battery or remove spark plug wire (for gasoline engines) before making any repairs.
- Before servicing machine, carefully release pressure from any components with stored energy, such as hydraulic components.
- Keep all nuts and bolts tightened, especially blade attachment bolts.
- Securely support any machine elements that must be raised for service work. Use jack stands or lock service latches to support components when needed.
- Never run engine unless park brake is locked.
- Use care when checking blades. Wrap blades or wear gloves and use caution when servicing them. Only replace blades. Never straighten or weld them.
- Keep all parts in good condition and properly installed. Fix damage immediately. Replace worn or broken parts. Replace all worn or damaged safety and instruction decals.
- Grass catcher components are subject to wear, damage, and deterioration which could expose moving parts or allow objects to be thrown. Check components frequently and replace with manufacturer's recommended parts when necessary.
- Charge batteries in an open, well-ventilated area, away from sparks. Unplug battery charger before connecting or disconnecting from the battery. Wear protective clothing and use insulated tools.
- Do not modify machine or safety devices. Unauthorized modifications may impair its function and safety.
- Check brake operation frequently. Adjust and service as needed.

SAFETY

Prevent Fires

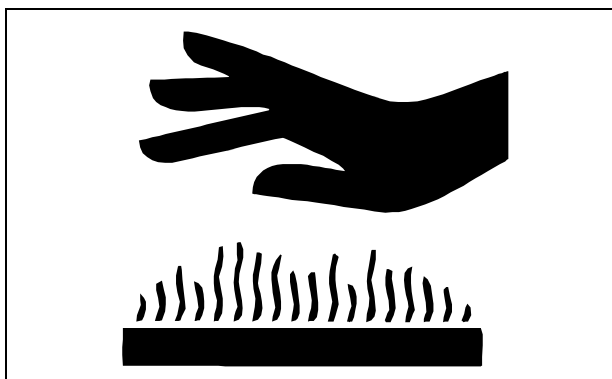

- Remove grass and debris from engine compartment and muffler area, before and after operating machine, especially after mowing or mulching in dry conditions.
- To reduce fire hazard, keep engine and engine compartment free of grass, leaves, or excessive grease.
- Clean up oil or fuel spillage.
- Allow engine to cool before storing in any enclosure.
- Never remove fuel cap, or add fuel with engine running or hot. Allow engine to cool for several minutes.
- Never store equipment with fuel in the tank inside a building where fumes may reach an open flame or spark.
- Always shut off fuel when storing or transporting machine.

Tire Safety



Explosive separation of a tire and rim parts can cause serious injury or death:

- Do not attempt to mount a tire without the proper equipment and experience to perform the job.
- Always maintain the correct tire pressure. Do not inflate the tires above the recommended pressure. Never weld or

heat a wheel and tire assembly. The heat can cause an increase in air pressure resulting in a tire explosion. Welding can structurally weaken or deform the wheel.

- When inflating tires, use a clip-on chuck and extension hose long enough to allow you to stand to one side and NOT in front of or over the tire assembly.
- Check tires for low pressure, cuts, bubbles, damaged rims or missing lug bolts and nuts.

Handling Fuel Safely

Fuel and fuel vapors are highly flammable:



- Do not refuel machine while you smoke, when machine is near an open flame or sparks, or when engine is running. Stop engine and allow to cool before filling.
- Never remove the fuel cap or add fuel with the engine running.
- Replace all fuel tanks and container caps securely.
- Never fill fuel tank or drain fuel from a machine in an enclosed area. Fill fuel tank outdoors.
- Prevent fires. Clean up spilled fuel immediately. If fuel is spilled on clothing, change clothing immediately. Do not attempt to start the engine but move the machine away from the area of spillage and avoid creating any source of ignition until fuel vapors have dissipated.
- Do not store fuel in container or machine with fuel in tank in a building where fumes may reach an open flame or spark.
- Prevent fire and explosion caused by static electric discharge. Use only non-metal, portable fuel containers approved by the Underwriter's Laboratory (U.L.) or the American Society for Testing & Materials (ASTM). If using a funnel, make sure it is plastic and has no screen or filter.

SAFETY

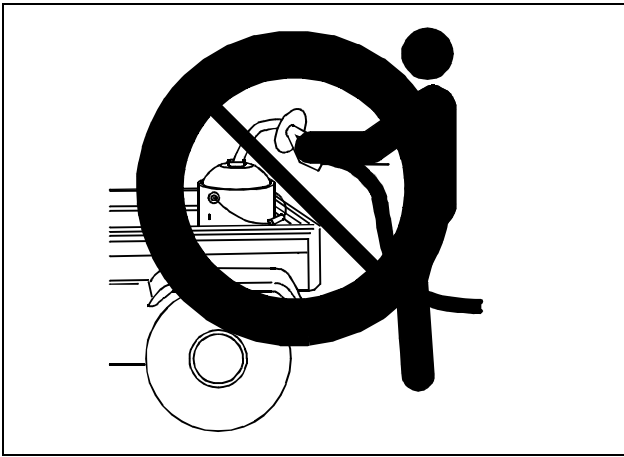

safety procedures, and emergency response techniques. The seller of the chemical products used with your machine is responsible for providing the MSDS for that product.

- Static electric discharge can ignite gasoline vapors in an ungrounded fuel container. Remove the fuel container from the bed of a machine or trailer or the trunk of a car and place on the ground away from the machine before filling. Keep nozzle in contact with container opening while filling. Do not use a nozzle lock-open device.
- When practical, remove equipment from trailers or truck beds and refuel them on the ground. If this is not possible, use a portable, plastic fuel container to refuel equipment on a truck bed or trailer.
- For gasoline engines, do not use gas with methanol. Methanol is harmful to your health and to the environment.

Handling Waste Product and Chemicals

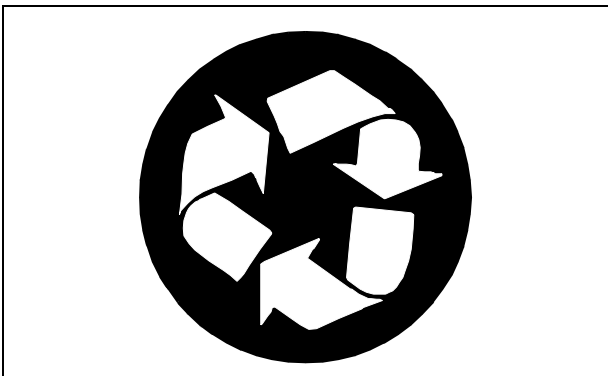

Waste products, such as, used oil, fuel, coolant, brake fluid, and batteries, can harm the environment and people:

- Do not use beverage containers for waste fluids - someone may drink from them.
- See your local Recycling Center or authorized dealer to learn how to recycle or get rid of waste products.
- A Material Safety Data Sheet (MSDS) provides specific details on chemical products: physical and health hazards,

OPERATING

Daily Operating Checklist

- Test safety systems.
- Check tire pressure.
- Check fuel level.
- Check engine oil level.
- Remove grass and debris from engine compartment and muffler area, before and after operating machine.
- Clean air intake screen.
- Check area below machine for leaks.

Avoid Damage to Plastic and Painted Surfaces

- Do not wipe plastic parts unless rinsed first.
- Insect repellent spray may damage plastic and painted surfaces. Do not spray insect repellent near machine.
- Be careful not to spill fuel on machine. Fuel may damage surface. Wipe up spilled fuel immediately.
- Prolonged exposure to sunlight will damage the hood surface.

Operator Station Controls

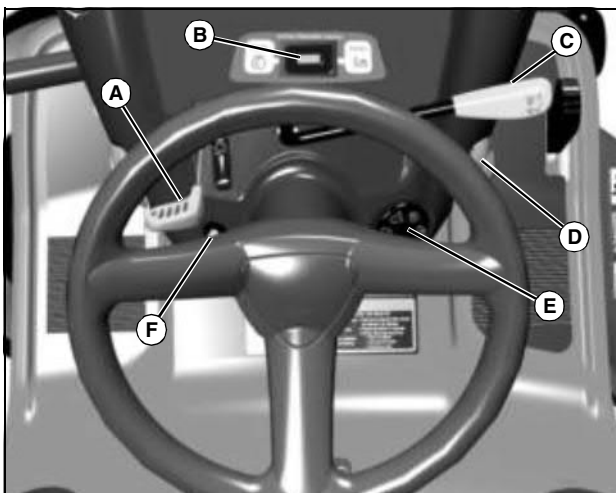

Picture Note: Console on Models L100 and L110; Model L110 shown.

- A - Throttle/Choke Lever**
- B - Service Reminder/Hour Meter (On Model L110)**
- C - Mechanical PTO Lever**
- D - Cruise Control Lever (On Model L110); Storage Retainer (On Model L100)**
- E - Key Switch**
- F - Reverse Implement Option (RIO) Switch**

- E - Key Switch**
- F - Reverse Implement Option (RIO) Switch**

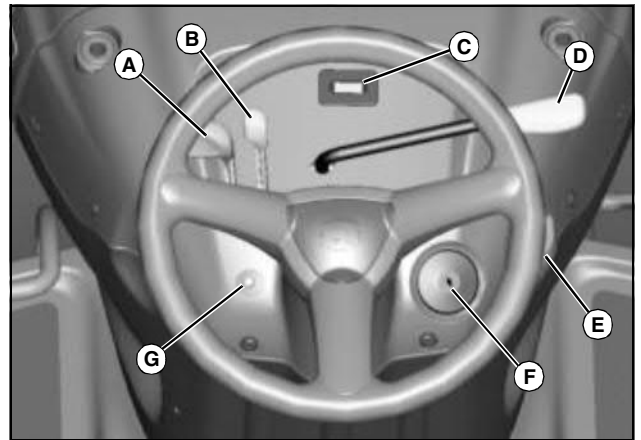

MX16534

Picture Note: Console on Model L118

- A - Throttle Lever**
- B - Choke Lever**
- C - Service Reminder/Hour Meter**
- D - Mechanical PTO Lever**
- E - Cruise Control Lever**
- F - Key Switch**
- G - Reverse Implement Option (RIO) Switch**

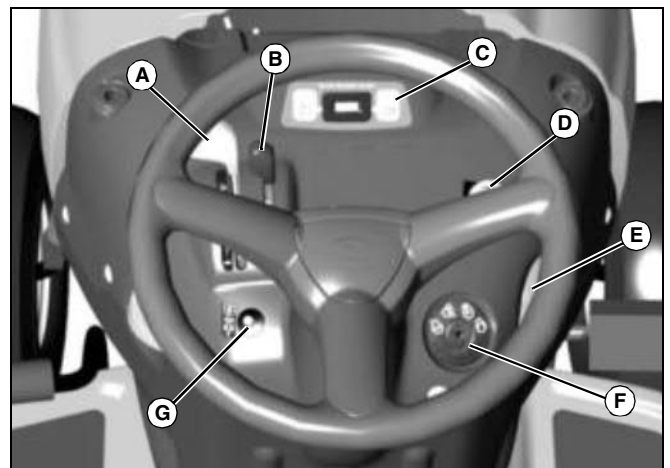

MX10501

Picture Note: Console on Models L120 and L130

- A - Throttle Lever**
- B - Choke Lever**
- C - Service Reminder/Hour Meter**
- D - Electric PTO Switch**
- E - Cruise Control Lever**
- F - Key Switch**
- G - Reverse Implement Option (RIO) Switch**

OPERATING

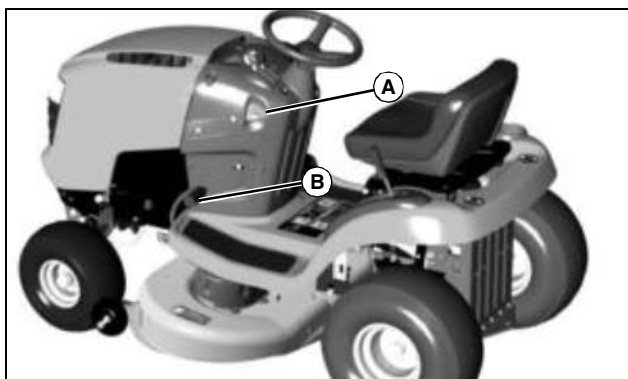

MX7694Y

- A - Park Brake Lock Lever
- B - Brake/Clutch Pedal

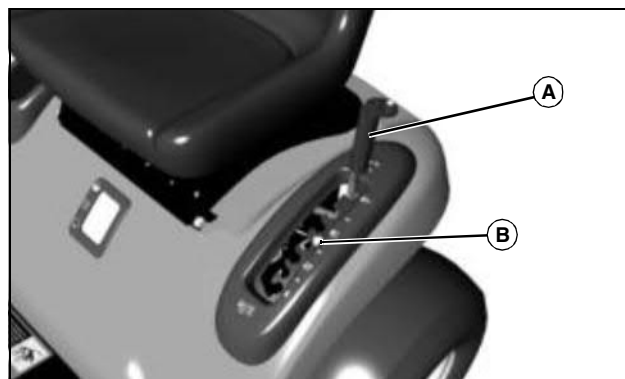

MX7695

- A - Attachment Lift Lever
- B - Mower Deck Height Reminder Tab

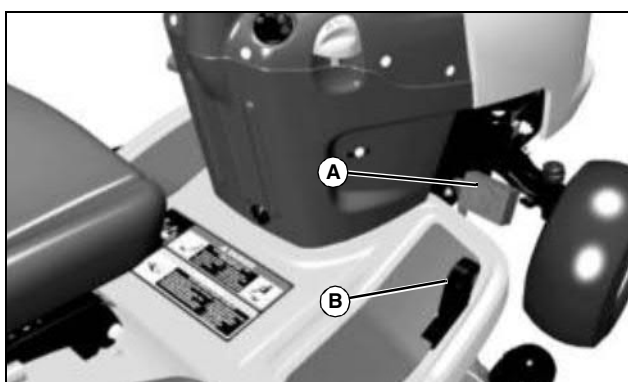

MX7696

Picture Note: Automatic/Foot Control Models Only

- A - Forward Travel Pedal
- B - Reverse Travel Pedal

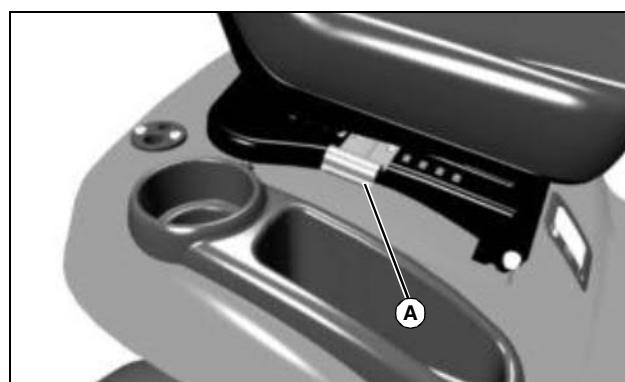

MX7698

- A - Seat Adjustment Lever

Miscellaneous Controls



MX10503

Picture Note: Gear Model Only

- A - Transmission Shift Lever

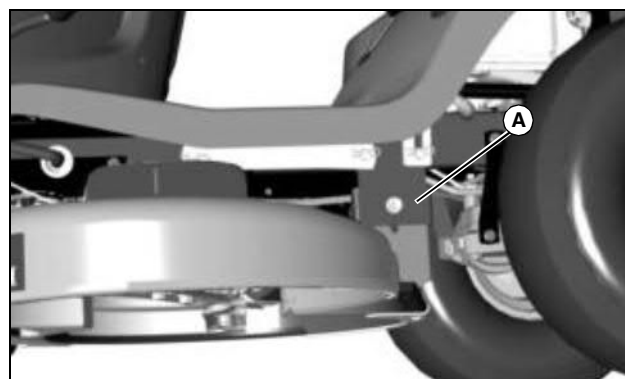

MX10513Y

- A - Mower Deck Leveling Bracket

OPERATING

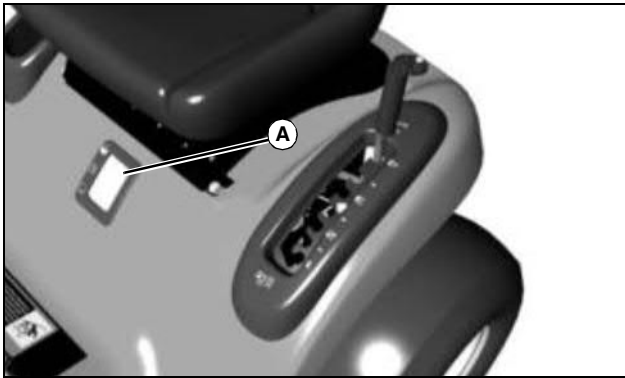

MX7695

A - Fuel Level Window

Miscellaneous Accessories



MX7694

A - Front and Rear Cargo Mount System™

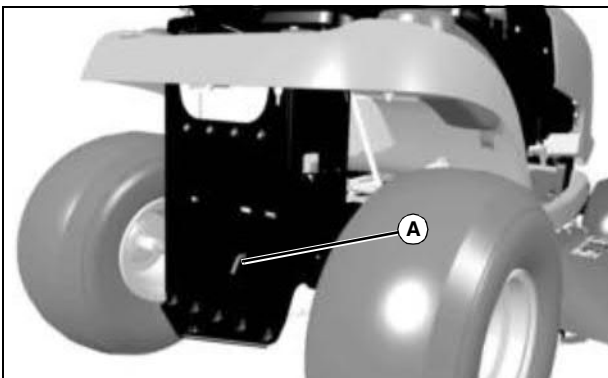

MX7691

A - Free-Wheeling Lever (Foot Control Models)

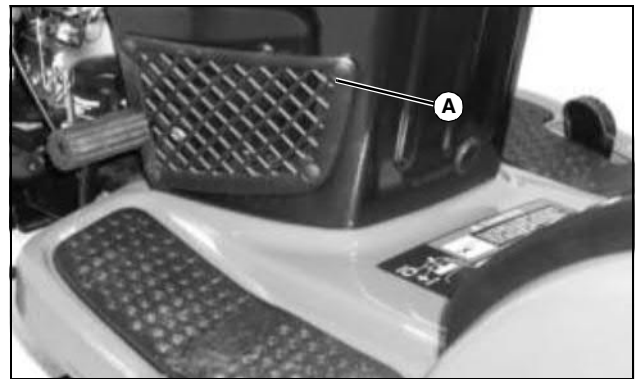

MX10524

A - Glove Storage Pocket

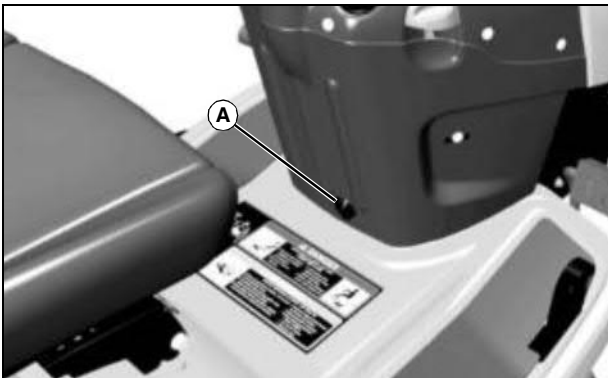

MX7696

A - Power Port (On Models L120 and L130)

Adjusting Seat

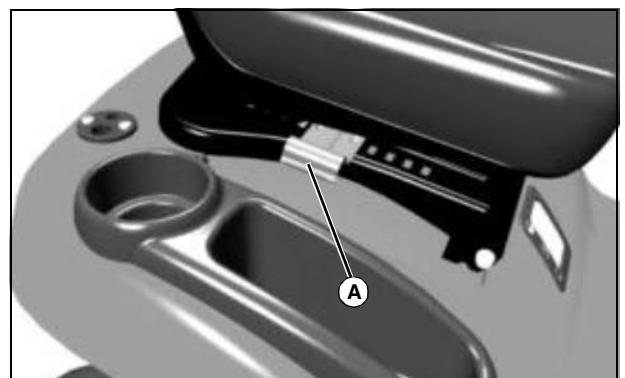

MX7698

1. Sit in seat.
2. Lift up on bracket (A).
3. Lean forward and slide seat forward or rearward to desired position. Do not lean back on seat to push rearward.

OPERATING

4. Release bracket to lock in position.

Adjusting Cutting Height

Cutting height can be adjusted from approximately 25–100 mm (1–4 in.). When mower deck is in transport position, cutting height is approximately 100 mm (4 in.).

Mower Setting	Approximate Cutting Height
1	25 mm (1 in.)
–	38 mm (1 1/2 in.)
2	50 mm (2 in.)
–	65 mm (2 1/2 in.)
3	75 mm (3 in.)
–	90 mm (3 1/2 in.)
4 (Transport)	100 mm (4 in.)

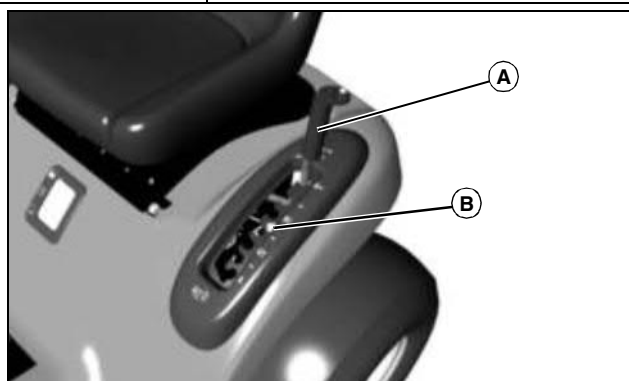

MX7695

1. Put attachment lift lever (A) into the slot adjacent to desired cutting height.

- Slide the height reminder tab (B) to the desired cutting height for the next time you mow.

2. Adjust mower deck wheels.

Checking Mower Level

CAUTION: Avoid injury! Rotating blades are dangerous. Before adjusting or servicing mower:

- Disconnect spark plug wire(s) or battery negative (-) cable to prevent engine from starting accidentally.
- Always wear gloves when handling mower blades or working near blades.

NOTE: Mower wheels should not contact the ground when leveling the deck.

1. Park machine safely. (See Parking Safely in the SAFETY section.)
2. Inflate tires to the correct pressure.
3. Move mower lift handle to preferred cutting height.
4. Measure mower level (side-to-side).

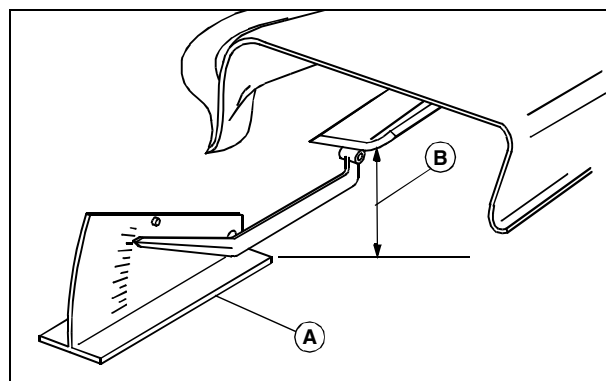

MX4871

Picture Note: A convenient leveling gauge (A) (AM130907) is available from your dealer.

- a. Position mower blades as follows and measure from each outside blade tip (B) to the level surface.

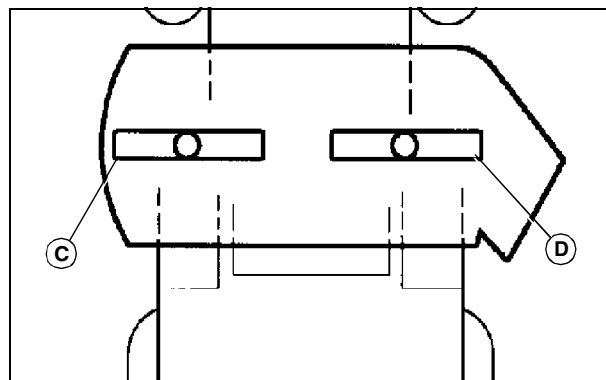

MX4896

- b. Turn left blade (C) as shown. Hold drive belt and turn right blade (D) as shown. Take measurement for both

OPERATING

blades.

The difference between blade measurements must not be more than 3 mm (1/8 in.).

c. Adjust mower level, if necessary.

5. Measure mower level (front-to-rear).

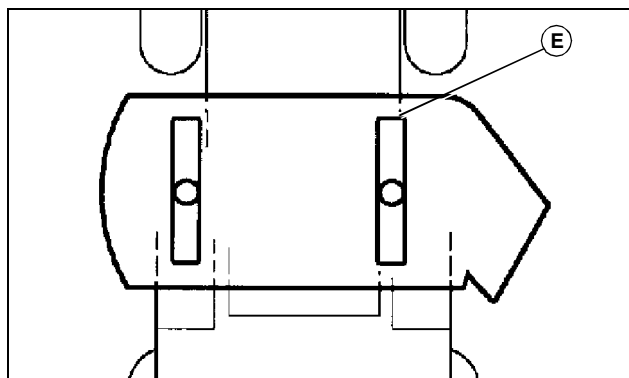

MX4896a

a. Turn right blade (E) so blade tip points straight forward.

b. Measure from blade tip to the surface. Take measurement for both blades.

The front blade tip must be 3–6 mm (1/8 - 1/4 in.) lower than rear blade tip.

c. Adjust mower level, if necessary.

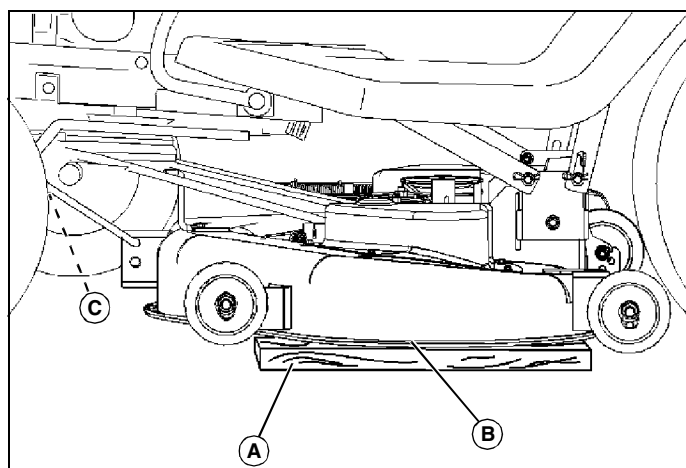

MX7674; MX7674bY

Picture Note: 107 cm (42 in.) used for lower illustration.

Adjusting Mower Level



CAUTION: Avoid injury! Rotating blades are dangerous. Before adjusting or servicing mower:

- Disconnect spark plug wire(s) or battery negative (-) cable to prevent engine from starting accidentally.
- Always wear gloves when handling mower blades or working near blades.

NOTE: Mower wheels should not contact the ground when leveling the deck.

1. Make sure machine is on a flat level surface.
2. Raise mower deck to highest position.

3. Place a straight 2x4 piece of wood (A) or a 38 mm (1.5 in.) thick block under the edge (B) of each side of mower deck.

- Shims can be added, on both sides, between block of wood and mower deck edge to obtain a specific deck height, if desired.

4. Put mower lift handle in the lowest position, bringing deck down onto blocks.

5. Check that blocks are positioned under each edge. Make sure blocks do not interfere with gage wheels.

6. Check that there is no tension on the front draft arm. If necessary, loosen adjusting nut (C) on front draft arm so front of deck rests on wood blocks.

7. On 122 cm (48 in.) deck: Remove mower drive belt from the engine drive sheave to release belt tension.

OPERATING

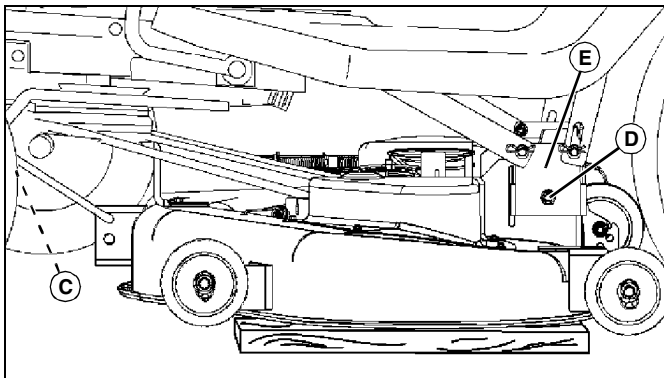

MX7674

8. Loosen leveling nut (D), one on each side, and make sure bolts and leveling brackets (E) slide freely in slots.
9. Raise lift handle to highest position and then lower back down to 25 mm (1 in.) cutting height to position the deck and brackets.
10. Apply slight pressure on leveling brackets (E), one on each side, by pulling down to remove slack in linkage. Tighten nuts (D), one on each side, to 55 N•m (40 ft-lbs).
11. Turn adjusting nut (C) on front draft arm clockwise until deck begins to raise off wood blocks.
12. On 122 cm (48 in.): Put lift lever in the lowest position and install mower drive belt on engine drive sheave.
13. Set preferred cutting height.
14. Check front-to-rear mower level again and adjust if necessary.

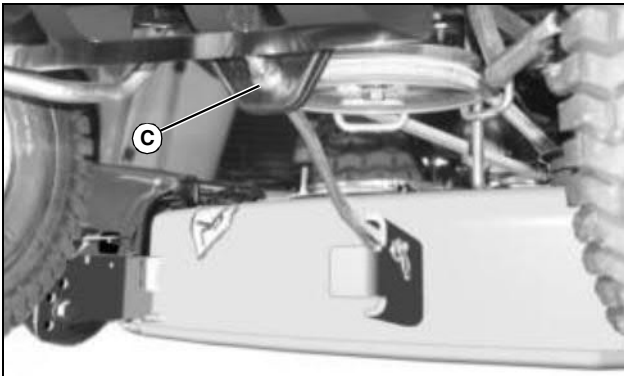

MX10529Y

Picture Note: 107 cm (42 in.) shown.

- Turn front adjusting nut (C) clockwise to raise front of mower deck or counterclockwise to lower front of mower deck.

Adjusting Mower Deck Wheels



CAUTION: Avoid injury! Rotating blades are dangerous. Before adjusting or servicing mower:

- Disconnect spark plug wire(s) or battery negative (-) cable to prevent engine from starting accidentally.
- Always wear gloves when handling mower blades or working near blades.

IMPORTANT: Avoid damage! The mower deck can be damaged if mower wheels are adjusted wrong:

- Wheels must not ride on ground supporting mower weight.
- Check wheel adjustment each time cutting height is changed.

1. Park machine safely. (See Parking Safely in the SAFETY section.)
2. Inflate tires to the correct pressure.
3. Lower mower deck to the desired mowing position.

NOTE: Bottom of wheels should be approximately 3-13 mm (1/8-1/2 in.) from the ground.

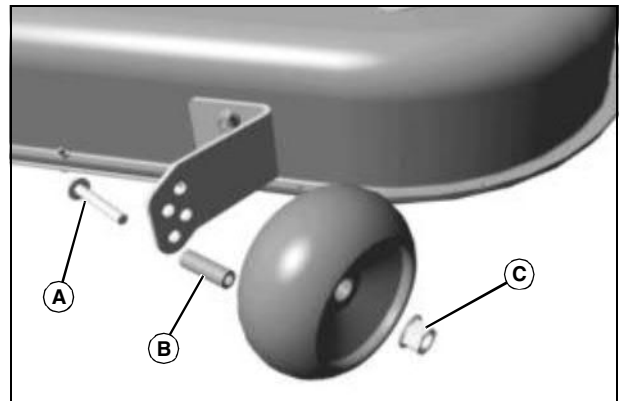

MX10509

4. Check mower wheel position. Remove bolt (A), bushing (B), and nut (C) and move mower wheels to proper hole.

OPERATING

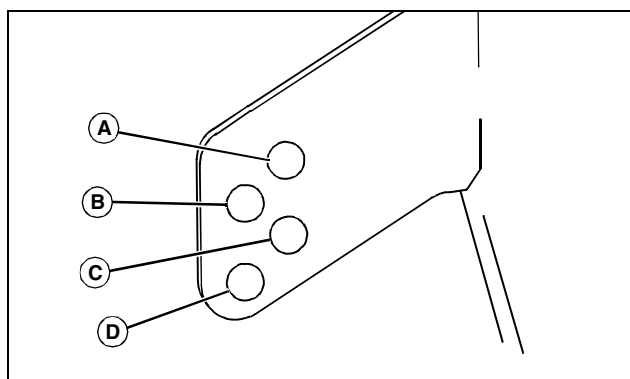

M92897 mif

- A - 38 mm (1.5-In.)
- B - 51 mm (2-In.)
- C - 64 mm (2.5-In.)
- D - 76 mm (3-In.) and above

5. Install bolts, bushings and nuts to lock wheels in position. Tighten nuts to 34 N•m (25 lb-ft).

Testing Safety Systems

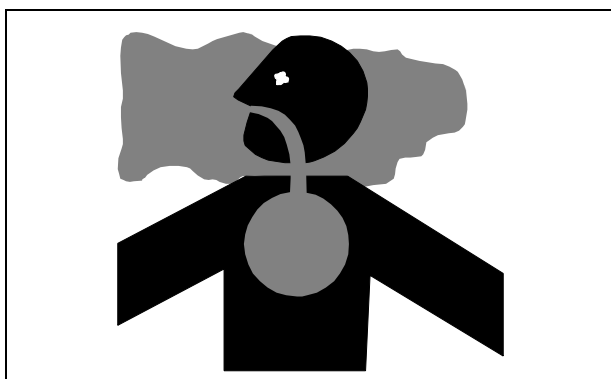

CAUTION: Avoid injury! Engine exhaust fumes contain carbon monoxide and can cause serious illness or death.

Move the machine to an outside area before running the engine.

Do not run an engine in an enclosed area without adequate ventilation.

- **Connect a pipe extension to the engine exhaust pipe to direct the exhaust fumes out of the area.**
- **Allow fresh outside air into the work area to clear the exhaust fumes out.**

The safety systems installed on your machine should be

checked before each machine use. Be sure you have read the machine operator manual and are completely familiar with the operation of the machine before performing these safety system checks.

Use the following checkout procedures to check for normal operation of machine.

If there is a malfunction during one of these procedures, do not operate machine. **See your authorized dealer for service.**

Perform these tests in a clear open area. Keep bystanders away.

Testing Park Brake Switch

1. Park machine safely. (See Parking Safely in the SAFETY Section.)
2. Sit on seat.

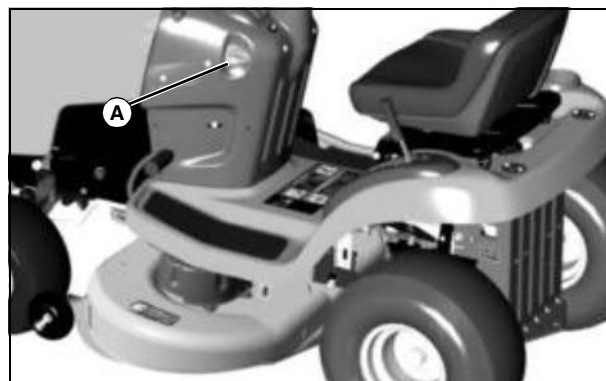

MX7694Y

3. Unlock the park brake (A).
4. Try to start engine.

Result: Engine must not start. If engine starts, there is a problem with your safety interlock circuit.

Testing Park Brake

1. Park machine safely. (See Parking Safely in the SAFETY Section.)

OPERATING

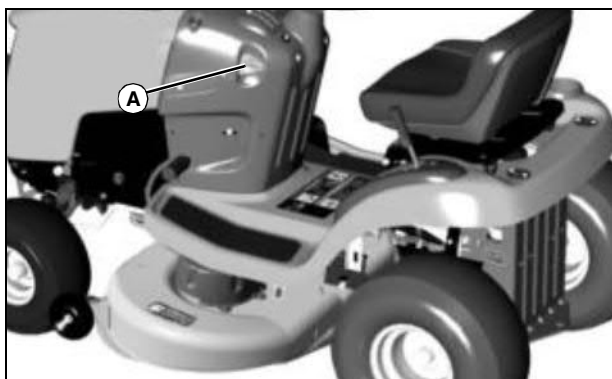

MX7694Y

2. Lock the park brake (A).
3. Put transmission in neutral. Engage free-wheeling lever on units with an automatic transmission.
4. Try to push machine manually.

Result: Park brake must prevent machine from moving. If machine moves, parking brake needs to be adjusted.

Testing PTO Switch



CAUTION: Avoid injury! The mower blades should stop in approximately five seconds when the mower or PTO is disengaged.

If you believe that your blades may not be stopping in that period of time, take your machine to your authorized dealer where they can safely check and service your machine.

1. Park machine safely. (See Parking Safely in the SAFETY Section.)
2. Sit on seat.

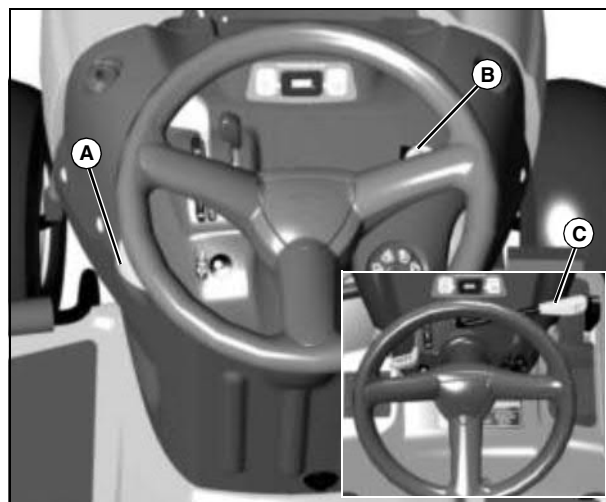

MX10501; MX7697

3. Lock the park brake (A).
4. Engage PTO:
 - On models with electric PTO, pull PTO switch (B) up.
 - On models with mechanical PTO, push PTO lever (C) forward.
5. Try to start engine.

Result: Engine must not start. If engine starts, there is a problem with your safety interlock circuit.

Testing Seat Switch

1. Park machine safely. (See Parking Safely in the SAFETY Section.)
2. First test:
 - a. Start engine.

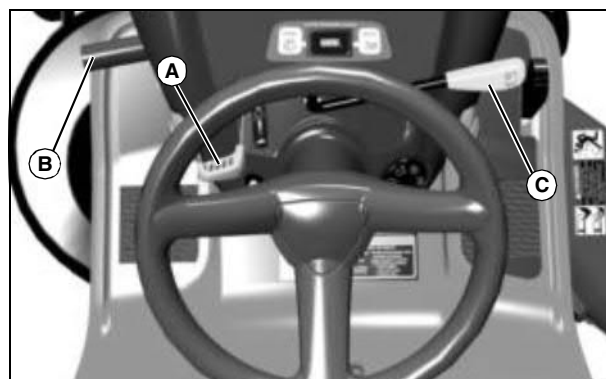

MX7697

Picture Note: Machine with mechanical PTO shown.

- b. Move throttle lever (A) up to maximum engine speed.
- c. Unlock park brake and release brake pedal (B).

OPERATING

- d. Engage PTO (C).
- e. Raise up off seat. Do not get off machine.

Result: Engine and mower blades should begin to stop. If engine and mower blades do not begin to stop, there is a problem with your safety interlock circuit.

3. Second test:



Picture Note: Machine with mechanical PTO shown.

- a. Disengage PTO (C).
- b. Start engine.
- c. Unlock park brake and release brake pedal (B).
- d. Raise up off seat. Do not get off machine.

Result: Engine should begin to stop. If engine does not begin to stop, there is a problem with your safety interlock circuit.

4. Third test:



Picture Note: Machine with mechanical PTO shown.

- a. Disengage PTO (C).
- b. Start engine.
- c. Lock park brake.
- d. Raise up off seat. Do not get off machine.

Result: Engine should continue to run. If engine stops, there is a problem with your safety interlock circuit.

Testing Reverse Implement Option (RIO)

- 1. Park machine safely. (See Parking Safely in the SAFETY section.)
- 2. Start engine.
- 3. Engage PTO to start attachment.

CAUTION: Avoid injury! Rotating blades are dangerous. Children or bystanders may be injured by runover and rotating blades.
Before backing up, carefully check the area around the machine.

- 4. Look behind the vehicle to be sure there are no bystanders.
- 5. Begin reverse travel by depressing reverse foot pedal for automatic transmission or moving gear shift lever to R (reverse) position for gear transmission.

Result: Mower and engine should stop operation. If mower or engine continues to operate as tractor begins travel in reverse, do not continue to operate mower.

Using the Park Brake

CAUTION: Avoid injury! Children or bystanders may attempt to move or operate an unattended machine.
Always lock the park brake and remove the key before leaving the machine unattended.

Locking park brake:

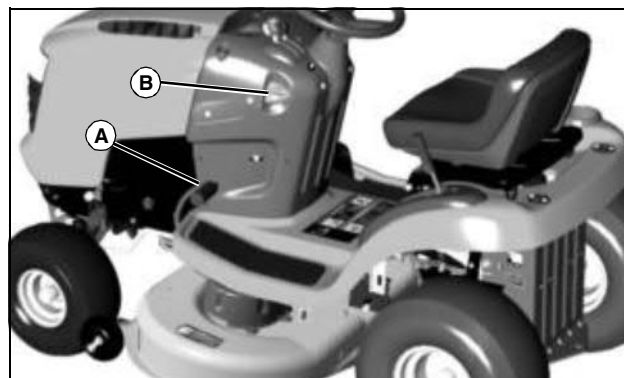

- 1. Push and hold brake pedal (A) down.

OPERATING

2. Pull park brake lever (B) up to lock park brake.
3. Release brake pedal. Pedal should stay down and park brake lever should stay locked.

Unlocking park brake:

1. Push and hold brake pedal down.
2. Push park brake lever down to unlock park brake.
3. Release brake pedal.

Using the Fuel Gauge

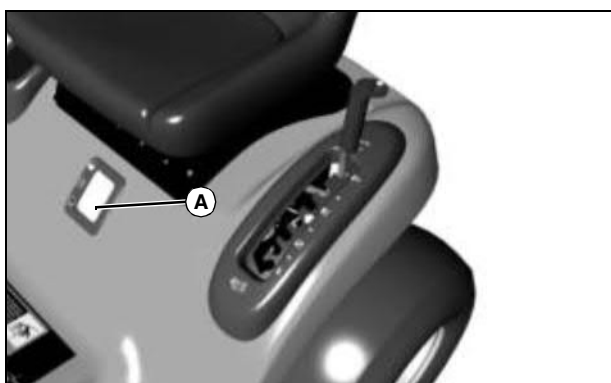

MX7695

Check fuel level at fuel window (A).

Using the Service Reminder (Models L110, L118, L120 and L130)

NOTE: Service hours will continue to run and service intervals will be wrong if key is not returned to STOP position.

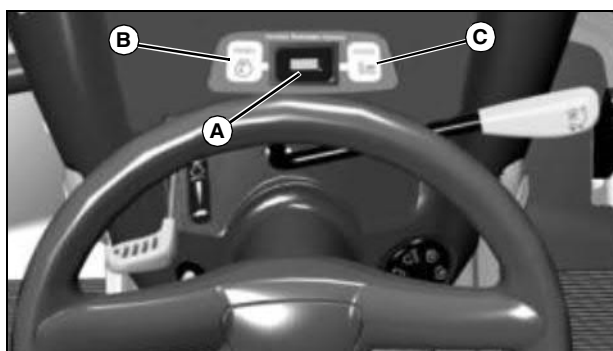

MX7697

- The service reminder (A) shows the number of hours the engine has run and will indicate that service is necessary for the engine (B) or the mower (C). When service is required, the service reminder will flash for two hours. Follow the service timetable on the maintenance schedule located under the seat and the SERVICE INTERVALS

section.

- Turn the key to STOP position when not using the machine.

Starting the Engine

IMPORTANT: Avoid damage! The transmission might be damaged if the free-wheeling lever is not pushed back to operating position before attempting to start the engine. Do not start or operate the machine with the free-wheeling lever in the push position.

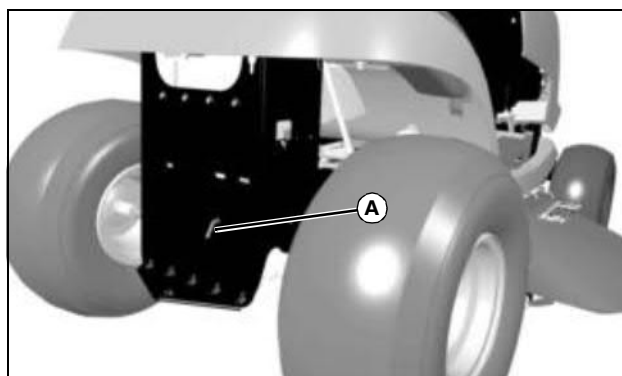

1. On automatic models: Make sure free-wheeling lever (A) is pushed in.

CAUTION: Avoid injury! Engine exhaust fumes contain carbon monoxide and can cause serious illness or death.

Move the machine to an outside area before running the engine.

Do not run an engine in an enclosed area without adequate ventilation.

- Connect a pipe extension to the engine exhaust pipe to direct the exhaust fumes out of the area.
- Allow fresh outside air into the work area to clear the exhaust fumes out.

2. Sit in seat.
3. Disengage mower blades.
4. Lock the park brake.
5. Put transmission in neutral.
6. Check starting conditions:

OPERATING

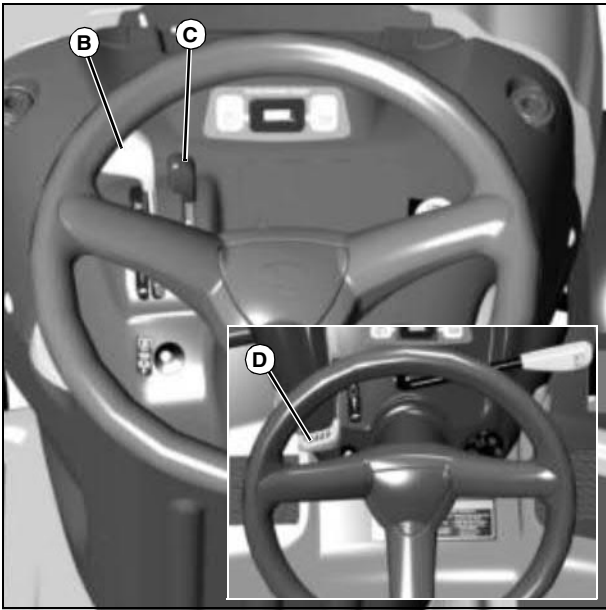

MX10501; MX7697

- If engine is cold:

On Models L118, L120 and L130, move throttle lever (B) to the half-speed position and move choke lever (C) up to the choke position.

On all other Models, move throttle/choke lever (D) up to the choke position.

- If engine is warm: Move throttle lever to the half-speed position.

IMPORTANT: Avoid damage! Starter may be damaged if starter is operated for more than 20 seconds at a time:

- Wait two minutes before trying again if engine does not start.

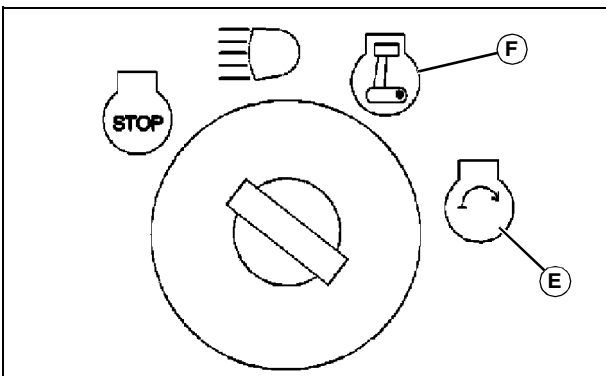

M94336a

7. Turn key to start position (E) for no more than five seconds.

8. Release key to run position (F) when engine starts and on models L118, L120 and L130, gradually move choke

lever down to the off position.

- If engine does not start, wait 10 seconds.
- Turn key to start position again for no longer than 5 seconds.
- Repeat procedure if necessary.

IMPORTANT: Avoid damage! Unnecessary engine idling may cause engine damage. Excessive idling can cause engine overheating, carbon build-up, and poor performance.

9. Let engine run at half-speed position for a couple of minutes to warm-up before operating machine.

Idling Engine

IMPORTANT: Avoid damage!

Unnecessary engine idling may cause engine damage. Excessive idling can cause engine overheating, carbon build-up, and poor performance.

Do not operate machine with hood open. Hood must be closed for proper engine cooling and exhaust.

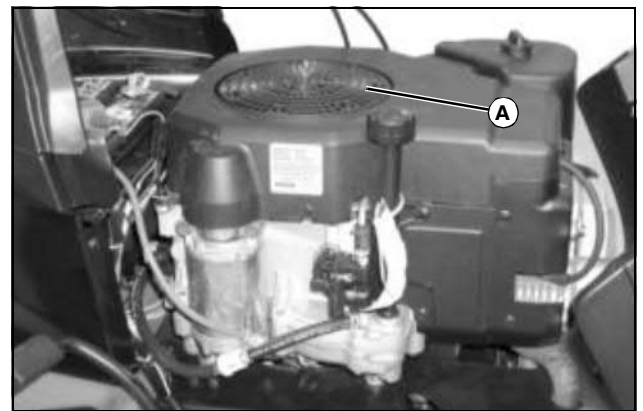

MX10526

Picture Note: Model with 17.5 hp engine used for photo purposes.

- Engine is air cooled and needs a large volume of air to keep cool. Keep air intake screen (A) on top of engine clean.
- Keep hood closed when engine is idling.

OPERATING

Stopping the Engine



MX7697

Picture Note: Model with mechanical PTO used for photo purposes.

1. Move throttle lever (A) to slow position and let engine run at low throttle a few seconds.

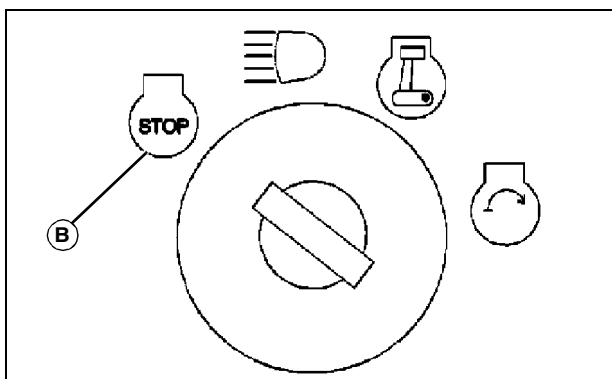

M94336a

2. Turn key to STOP position (B). Engine will stop and headlights will turn off.
3. Remove key.
4. Lock the park brake.

Using Headlights

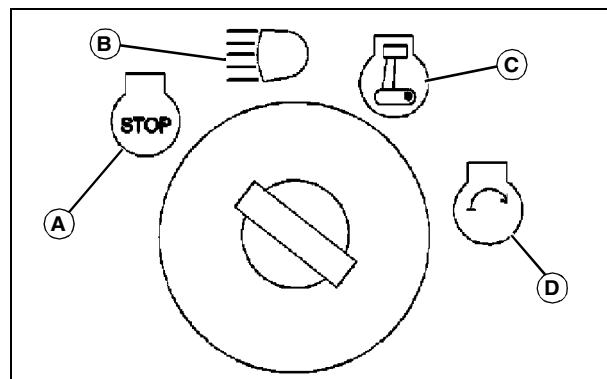

M94336a

- A - STOP Position
- B - Headlights On Position
- C - Run Position
- D - Start Position

Engine Off

NOTE: Headlights will drain the battery rapidly if key switch is left in headlights on position (B) with the engine off.

- To turn headlights on, turn key switch to headlights on position (B).
- To turn headlights off, turn key switch to STOP position (A).

Engine On

- To turn headlights on, start engine, then turn key switch from run position (C) to headlights on position (B).
- To turn headlights off, turn key switch from headlights on position (B) to run position (C).

Using Travel Controls on Gear Transmission



CAUTION: Avoid injury! Children or bystanders may be injured by runover and rotating blades. Before traveling forward or rearward:

- Carefully check the area around the machine.
- Disengage the mower before backing up.

IMPORTANT: Avoid damage! Stop machine movement before shifting between reverse and forward to prevent transmission damage.

OPERATING

Travel Forward

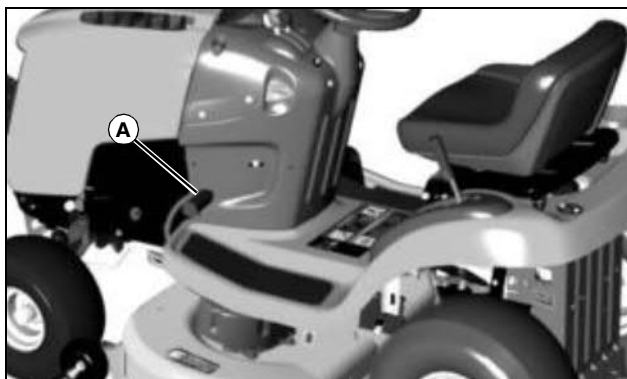

MX7694Y

1. Push brake/clutch pedal (A) all the way down to stop machine.



MX10502

2. Move transmission shift lever (B) to desired travel speed.
3. Release brake/clutch pedal slowly.

Travel in Reverse



MX7697

1. Push brake/clutch pedal (A) all the way down.

NOTE: Any operating attachment and the engine will stop as the gear shift lever is moved to R (reverse) with attachment engaged.

2. Pull PTO lever (C) back to the off position to disengage attachment.
3. Look behind the machine to be sure there are no bystanders nearby.

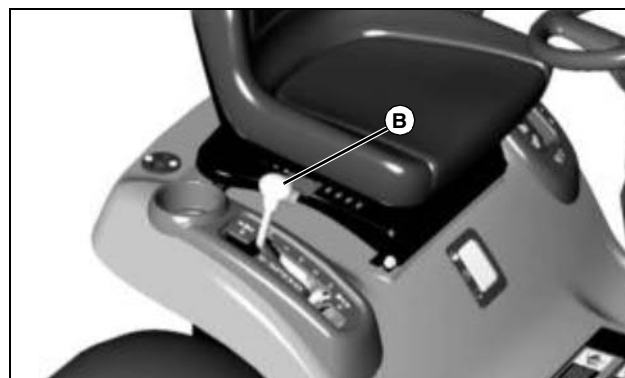

MX10503

4. Move shift lever (B) to R (reverse) position.
5. Release brake/clutch pedal slowly.

Emergency Stopping

Push down brake/clutch pedal.

Using Travel Controls on Automatic Transmission



CAUTION: Avoid injury! Children or bystanders may be injured by runover and rotating blades. Before traveling forward or rearward:

- Carefully check the area around the machine.
- Disengage the mower before backing up.

OPERATING

Travel Forward

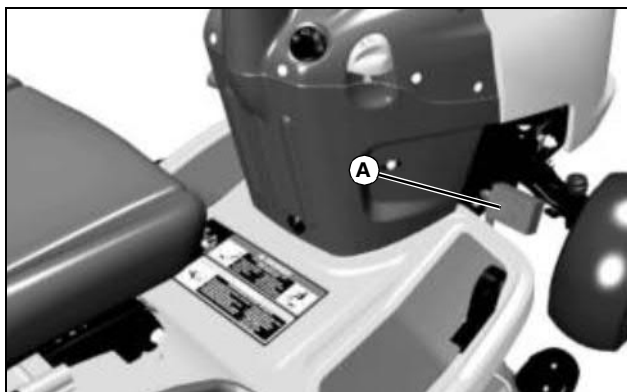

MX7696

- Push down the forward travel pedal (A).

Travel in Reverse

NOTE: Any operating attachment and the engine will stop as the reverse foot pedal is depressed with attachment engaged.

1. Disengage attachment:



MX7697

- On models with mechanical PTO, pull PTO lever (B) back to the off position.



MX10501

- On models with electric PTO, push PTO switch (C) down to the off position.

2. Look behind the machine to be sure there are no bystanders nearby.

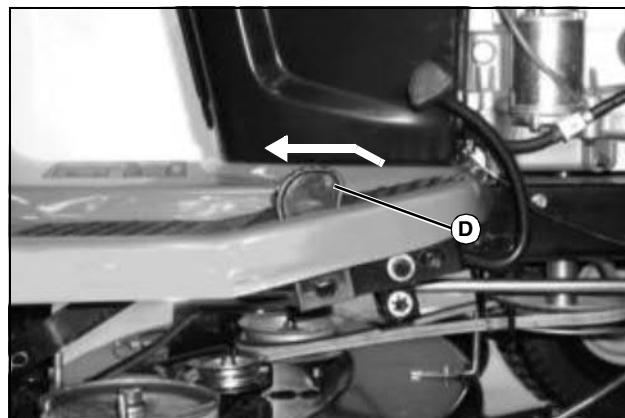

MX10530

3. Touch the reverse travel pedal (D) with front of foot and slide foot over pedal from front to rear.

Emergency Stopping

- Push down brake pedal.

Using The Reverse Implement Option (RIO)

CAUTION: Avoid injury! Rotating blades are dangerous. Children or bystanders may be injured by runover and rotating blades.
Before backing up, carefully check the area around the machine.

NOTE: Backing up while the mower is engaged is strongly discouraged. The Reverse Implement Option should be used only when operating another attachment or when the operator deems it necessary to reposition the machine with the mower engaged.

1. Stop forward travel.
2. Look behind the machine to be sure there are no bystanders.

OPERATING



MX7697Y

3. Push and hold in the reverse implement switch (A) while depressing reverse foot pedal slightly for automatic transmission or moving the gear shift lever to the R (reverse) position for gear transmission.

NOTE: If the engine and mower stop while repositioning the machine, return the PTO lever/switch to the off position. Start engine and engage mower. Begin again with Step 2.

4. Release the reverse implement switch and reposition the machine as the machine begins to move rearward.
5. Resume forward travel. The mower should continue operating.
6. Repeat procedure to position the machine again.

Using Cruise Control (On Models L110, L118, L120 and L130)

CAUTION: Avoid injury! Do not use cruise control when going down hills. Machine speed will increase. Operate machine in a large, open area to learn how the cruise control works.

Use cruise control when you want to maintain travel speed without having to hold the forward travel pedal down. Cruise control operates only for forward travel.

Engage Cruise Control



MX7696

1. Push forward pedal down until you reach desired travel speed.
2. Pull lever (A) up and release forward pedal to lock the cruise control.

Disengage Cruise Control

- Depress brake pedal, tap on forward pedal or push cruise control lever down to the off position.

Using Mower Lift Lever

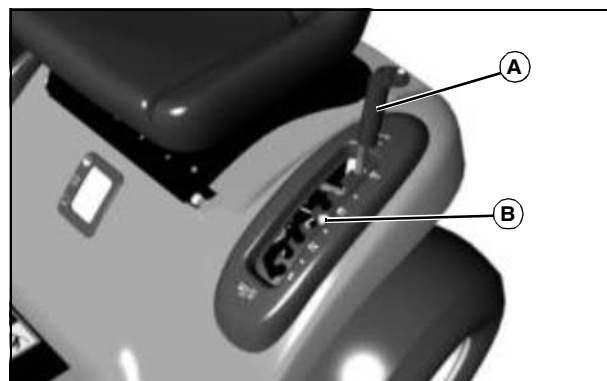

MX7695

Transporting or Getting On and Off Machine

- Pull lift lever (A) all the way back to transport position or 100 mm (4 in.) cutting height.

Mowing

- Push attachment lift lever (A) forward into the slot adjacent to the desired cutting height.
- Slide the mower deck height reminder tab (B) to the desired cutting height for the next time you mow.

OPERATING

Using Mower

- CAUTION: Avoid injury! Stay clear of rotating drivelines:**
- Entanglement in rotating driveline can cause serious injury or death.
 - Keep hands, feet and clothing away.
 - Make sure that all shields are installed and used properly.
 - Stop the engine and be sure PTO driveline is stopped before getting near it.

1. Start engine and run at half speed for a couple of minutes to warm up.
2. Lower mower to desired cutting height position.
3. Engage mower.

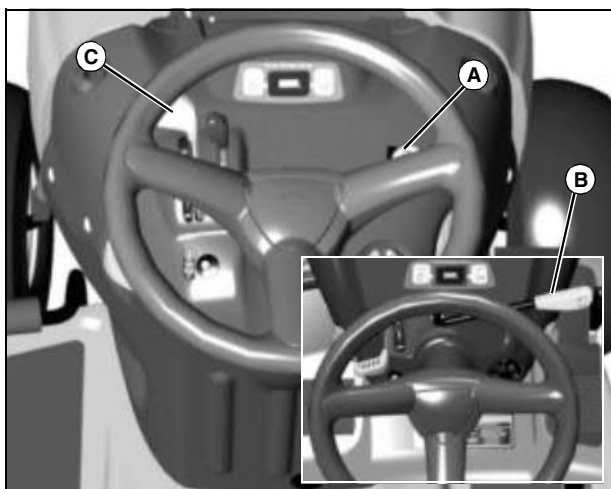

MX10501; MX7697

- On models with electric PTO: Pull PTO switch (A) up.
 - On models with mechanical PTO: Push PTO lever (B) forward.
4. Push throttle lever (C) up to the full throttle position.

NOTE: The mower and engine will stop as the reverse foot pedal is depressed for Automatic Transmission or when the gear shift lever is moved to the R (reverse) position for Gear Transmission with mower engaged.

5. Disengage mower blades before moving in reverse.
 - Tractors with mechanical PTO: Pull PTO lever back.
 - Tractors with electric PTO: Push PTO switch down.

Pushing Machine

- CAUTION: Avoid injury! With the free-wheeling valve open, the machine will have unrestricted motion.**
- The machine may free-wheel out of control if the free-wheeling valve is opened with the machine on an incline.
 - Park the machine on a level surface before opening the free-wheeling valve.

IMPORTANT: Avoid damage! Transmission damage may occur if the machine is towed or moved incorrectly:

- Move machine by hand only.
- Do not use another vehicle to move machine.
- Do not tow machine.

1. Unlock the park brake.
2. Put transmission in N (neutral).

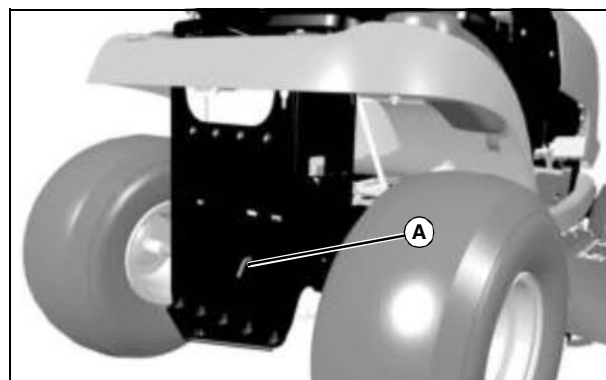

MX7691

3. On Automatic Models: Pull out on free-wheeling lever (A).
4. Push machine to desired location.

IMPORTANT: Avoid damage! The transmission might be damaged if the free-wheeling lever is not pushed back to operating position before attempting to start the engine. Do not start or operate the machine with the free-wheeling lever in the push position.

5. On Automatic Models: Push free-wheeling lever back in.

OPERATING

Unplugging Mower, Bagger, or Material Collection System



CAUTION: Avoid injury! Do not attempt to unplug attachment with machine running.

- Rotating blades are dangerous. Shut off the engine and remove the key before getting off the seat to inspect the machine and attachment.
- Thrown objects can cause serious injury. Make sure all machine parts are stopped before raising hopper top or removing chutes.

Checking For Plugging

Check the flow indicator on MCS chute (if equipped) periodically for any indication of loss of air flow.

If grass builds up in front of mower discharge chute, check for plugged chute or problems with blower assembly (if equipped).

If there is a trail of clippings behind mower or clippings blow to the side, check for plugged chute, full collector bags, or problems with blower assembly.

Removing Debris From Inspection Points:

1. Park machine safely. Wait for all moving parts to stop before getting off to inspect machine.
2. Open hopper cover. Check chute outlet.
3. Remove chute from mower deck or blower assembly. Check chute inlet.
4. Check under mower deck for debris.

Transporting Machine on Trailer

Be sure trailer has all the necessary lights and signs required by law.



CAUTION: Avoid injury! Use extra care when loading or unloading the machine onto a trailer or truck.

- Park trailer on a level surface.
- Use of a trailer with sides is recommended.
- Keep wheels away from drop-offs and edges.
- Back slowly and in a straight line.
- Close fuel shut-off valve, if your machine is equipped.

IMPORTANT: Avoid damage! Transmission damage may occur if the machine is towed or moved incorrectly:

- Move machine by hand only.
- Do not use another vehicle to move machine.
- Do not tow machine.

1. Park trailer on level surface.
2. Drive machine onto heavy-duty trailer.
3. Lower mower to trailer deck.
4. Lock park brake.
5. Turn off machine and remove key.
6. Fasten lawn tractor to trailer with heavy-duty straps, chains, or cables. Both front and rear straps must be directed down and outward from tractor.
7. Strap down hood.

Using Mulch Cover



CAUTION: Avoid injury! Rotating blades are dangerous. Before adjusting or servicing mower:

- Disconnect spark plug wire(s) or battery negative (-) cable to prevent engine from starting accidentally.
- Always wear gloves when handling mower blades or working near blades.

Side Discharge

1. Disconnect hooks from slot and/or wheel brackets and remove mulch cover when side discharge is preferred.
2. Make sure bagger blades are not installed for maximum side discharge operation.

OPERATING

Mulching



MX10441Y

Picture Note: 122 cm (48 in.) used for illustration.

1. Raise discharge chute (A) and metal deflector (B).

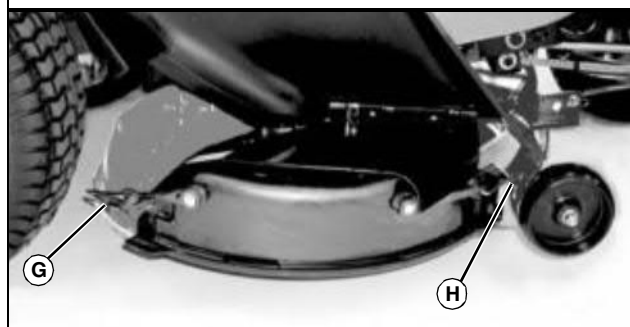
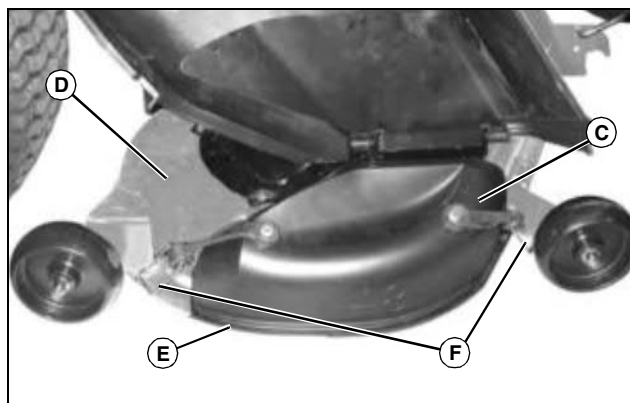

MX10440Y; MX8868Y

2. Install mulch cover (C) onto mower deck (D). Mulch cover lip (E) must be seated in mower deck groove.
3. Hook mulch cover to mower deck:
 - 122 cm (48 in.), wheel bracket grooves (F).
 - 107 cm (42 in.), slot (G) on left side and wheel bracket hole (H).
4. Lower discharge chute and metal deflector.
5. Make sure bagger blades are not installed for maximum mulching operation.

Using the Power Port (Models L120 and L130)

CAUTION: Avoid injury! Safe operation requires your full attention. Do not wear radio or music headphones while operating machine.

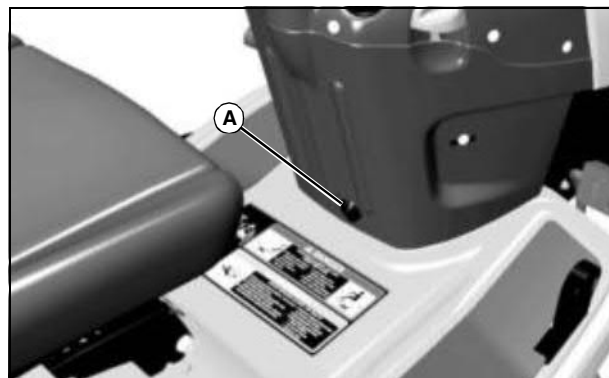

MX7696

An electric power port (A) can be used for accessories. See your authorized dealer.

Using CargO Mount System™



MX7694

A - Front and Rear CargO Mount System™

The front and rear CargO Mount System™ brackets (A) can be used for easy attachment of selected optional equipment.

Use John Deere approved optional equipment only. See your Authorized Service Center for approved optional equipment.

OPERATING

Using Storage Accessories

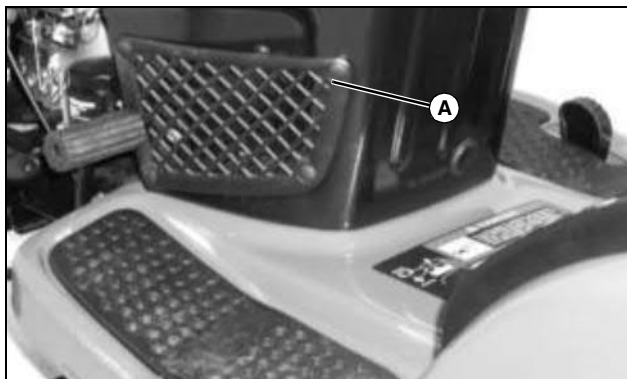

MX10524

A - Glove Storage Pocket

- Use the storage pocket (A) for small items such as gloves.



MX10528

- On Models Without Cruise Control: Use the storage retainer (B) to hold an electronic device such as garage door opener.

Using Weights



CAUTION: Avoid injury! The machine may become unstable when operating on slopes and/or with some attachments.

Use recommended front or rear weights to improve stability when operating on slopes or using attachments.

Remove weights when not required.

NOTE: See your authorized dealer for recommended weights.

- Install front weights for added stability and steering control when you use equipment such as the rear-mounted

grass bagger.

- Install rear weights when using the snow blade or snowblower.
- Remove weights when not required.

Using Tire Chains

Tire chains are recommended for use with front attachments.

See your Attachment Operator's Manual for tire chain recommendations. See your authorized dealer for tire chains.

Mowing Tips

The following recommendations will produce the best lawn cut quality and appearance:

- Keep mower blades sharp. Dull blades will tear grass; tips of grass will then turn brown.
- Cutting grass too short may kill grass and let weeds grow easily.
- Adjust cutting height to remove only 1/3 of the grass at a time.
- Mow grass often. Short grass clippings will decay quickly.
- Mow with engine at full throttle.
- Adjust travel speed to match mowing conditions:
 - Travel at slow speed when you mow thick, tall grass, make sharp turns, trim around objects, or when mulching.
 - Travel at moderate speed when you mow thin grass.
- Use a different mowing pattern each time you mow. Overlap mowing paths 50 to 100 mm (2 to 4 in).
- Drive over ridges and through shallow ditches straight-on, not at an angle.
- A thick layer of mulched leaves can prevent sunlight from getting to grass and smother it. Taller grass heights allow mulched leaves to dispense easier in lawn. Mulch leaves several times if needed.
- Use a thatcher in late spring or summer to pull up dead grass and aerate ground.

REPLACEMENT PARTS

Service Literature

If you would like a copy of the Parts Catalog or Technical Manual for this machine call:

- **U.S. & Canada:** 1-800-522-7448.
- **All Other Regions:** Your John Deere dealer.

Parts

We recommend John Deere quality parts and lubricants, available at your John Deere dealer.

Part numbers may change, use part numbers listed below when you order. If a number changes, your dealer will have the latest number.

When you order parts, your John Deere dealer needs the serial number or product identification number (PIN) for your machine or attachment. These are the numbers that you recorded in the Product Identification section of this manual.

Order Service Parts Online

Visit <http://JDParts.deere.com> for your Internet connection to parts ordering and information.

Part Numbers

ITEM	PART NUMBER
Home Maintenance Kit:	
• L100	LG239
• L110	LG240
• L118	LG230
• L120	LG230
• L130	LG199

(Part numbers are subject to change without notice. Part Numbers may be different outside the U.S.A.)

SERVICE INTERVALS

Servicing Your Machine

IMPORTANT: Avoid damage! Operating in extreme conditions may require more frequent service intervals:

- Engine components may become dirty or plugged when operating in extreme heat, dust or other severe conditions.
- Engine oil may lose efficiency if vehicle is operated constantly at slow or low engine speeds or with frequent short trips.

Please use the following timetables and the maintenance schedule located under the seat to perform routine maintenance on your machine.

Intervals

Before Each Use

- Check fuel level.
- Check engine oil level.
- Clean air intake screen.
- Check safety systems.
- Check tire pressure and brakes.
- Check/tighten loose hardware.

After First 5 Hours

- Change engine oil.
- On 107 cm (42 in.) deck: Check and adjust mower deck belt tension.
- On 107 cm (42 in.) deck: Check and adjust mower deck spindle brakes.
- On 137 cm (54 in.) deck: Lubricate mower deck spindles.
- Lubricate mower pivot points.
- Lubricate front axle pivot.
- Lubricate front wheel spindles and wheel bushings.

Every 25 Hours

- Lubricate front axle pivot.
- Lubricate front wheel spindles and wheel bushings.

Every 50 Hours

- Change engine oil. (Service more frequently under dusty conditions.)
- Replace oil filter.

- Clean/replace air filter precleaner. (Service more frequently under dusty conditions.)
- Check/replace air filter element. (Service more frequently under dusty conditions.)
- Clean engine cooling fins.
- Replace fuel filter.
- Replace spark plug.
- Check/clean battery terminals.
- Sharpen/replace blades.
- Check/replace mower drive belt.
- Clean mower deck.
- Check/level mower deck.
- On 107 cm (42 in.) deck: Check/adjust mower deck belt tension.
- On 107 cm (42 in.) deck: Check/adjust mower deck spindle brakes.
- On 137 cm (54 in.) deck: Lubricate mower deck spindles.
- Lubricate mower pivot points.

Before Storage

- Change engine oil.
- Replace oil filter.
- Clean/replace air filter precleaner.
- Check/replace air filter element.
- Clean air intake screen.
- Clean engine cooling fins.
- Replace fuel filter.
- Replace spark plug.
- Add fuel stabilizer.
- Check/clean battery terminals.
- Charge battery.
- Sharpen/replace mower blades.
- Check/replace mower drive belt.
- Clean mower deck.
- Check/level mower deck.
- On 107 cm (42 in.) deck: Check/adjust mower deck belt tension.
- On 107 cm (42 in.) deck: Check/adjust mower deck spindle brakes.
- On 137 cm (54 in.) deck: Lubricate mower deck spindles.
- Lubricate mower pivot points.

SERVICE INTERVALS

- Check safety systems.
- Check/tighten loose hardware.
- Check tire pressure and brakes.
- Lubricate front axle pivot.
- Lubricate front wheel spindles and wheel bushings.

After Storage

- Check/clean battery terminals.
- Charge battery.
- Check safety systems.
- Check/tighten loose hardware.
- Check tire pressure and brakes.

SERVICE LUBRICATION

Grease

IMPORTANT: Avoid damage! Use recommended John Deere greases to avoid component failure and premature wear.

The recommended John Deere greases are effective within an average air temperature range of -29 to 135 degrees C (-20 to 275 degrees F).

If operating outside that temperature range, contact your Servicing dealer for a special-use grease.

The following greases are preferred:

- John Deere Multi-Purpose SD Polyurea Grease
- John Deere Multi-Purpose HD Lithium Complex Grease
- John Deere Moly High Temperature EP Grease

If not using any of the preferred greases, be sure to use a general all-purpose grease with an NLGI grade No.2 rating.

Wet or high speed conditions may require use of a special-use grease. Contact your Servicing dealer for information.

Lubricating Front Axle Pivot



M92886

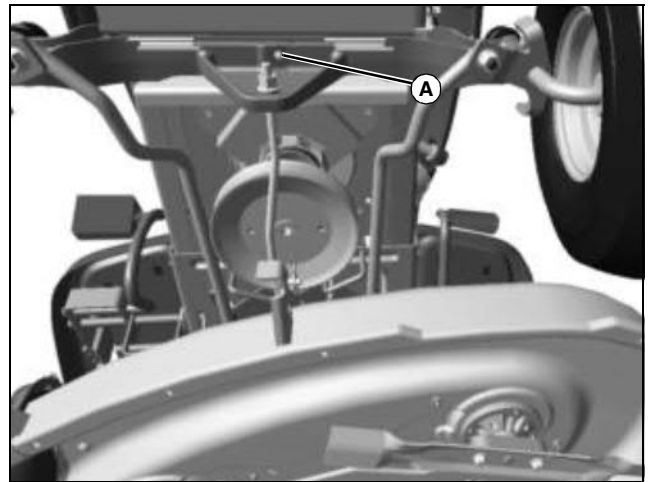

MX10500Y

- Lubricate front axle center pivot (A) with one or two shots of general all-purpose grease.

SERVICE LUBRICATION

Lubricating Front Axle Wheel Spindles and Bushings

- Lubricate these pivot points with a general all-purpose spray lubricant.

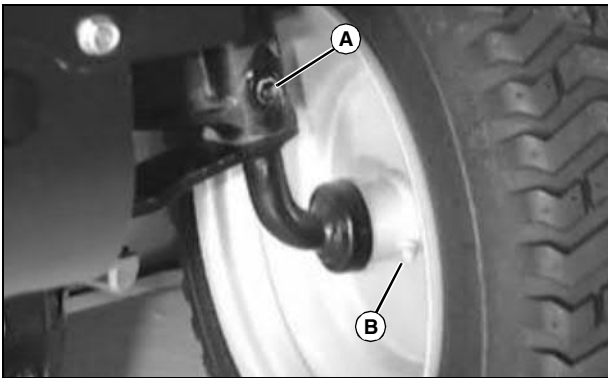

M88584

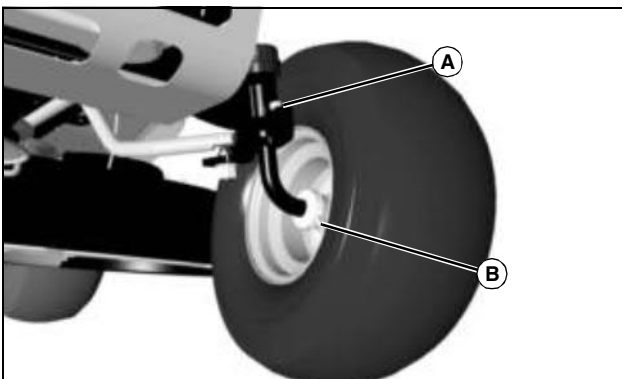

MX7700

- Lubricate front wheel spindles (A) and bushings (B), one on each side, with one or two shots of general all-purpose grease.

Lubricating Pivot Points

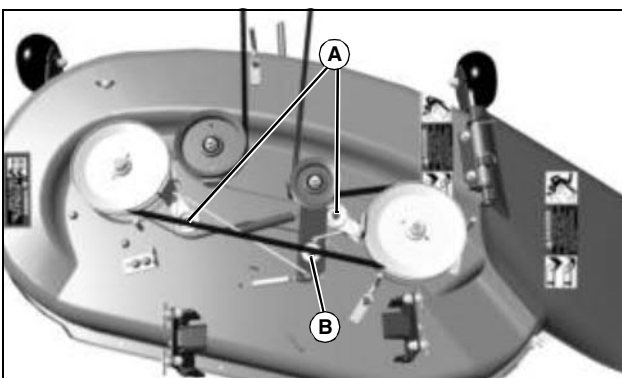

MX10512

Picture Note: 107 cm (42 in.) deck used for illustration.

- A - Blade Brake Pivots (107 cm (42 in.) deck only)**
- B - Deck Idler Pivot**

SERVICE ENGINE

Engine Warranty Maintenance Statement

Maintenance, repair, or replacement of the emission control devices and systems on this engine, which are being done at the customer's expense, may be performed by any non-road engine repair establishment or individual. Warranty repairs must be performed by an authorized John Deere dealer.

Avoid Fumes



CAUTION: Avoid injury! Engine exhaust fumes contain carbon monoxide and can cause serious illness or death.

Move the machine to an outside area before running the engine.

Do not run an engine in an enclosed area without adequate ventilation.

- **Connect a pipe extension to the engine exhaust pipe to direct the exhaust fumes out of the area.**
- **Allow fresh outside air into the work area to clear the exhaust fumes out.**

Engine Oil

Use oil viscosity based on the expected air temperature range during the period between oil changes.

The following John Deere oils are preferred:

- TURF-GARD™
- PLUS-4™

Other oils may be used if above John Deere oils are not available, provided they meet the following specification:

- API Service Classification SG or higher

Checking Engine Oil Level

IMPORTANT: Avoid damage! Failure to check the oil level regularly could lead to serious engine problems if oil level is low:

- **Check oil level before operating.**
- **Check oil level when the engine is cold and not running.**
- **Keep level between the FULL and the ADD marks.**
- **Shut off engine before adding oil.**

NOTE: Check oil twice a day if you run engine over 4 hours in a day.

Make sure engine is cold when checking engine oil level.

1. Park machine safely. (See Parking Safely in the SAFETY section.)
2. Lift hood.
3. Clean area around dipstick to prevent debris from falling into crankcase.



MX10526

Picture Note: Model with 17.5 hp engine shown.

4. Remove dipstick (A). Wipe with clean cloth.
5. Install dipstick.
 - Briggs and Stratton Engines: Install and tighten dipstick.
 - Kohler Engines: Install dipstick in tube, but do not tighten it. Let dipstick threads rest on top of tube, turn cap counterclockwise until it "clicks" or starts to engage threads.
6. Remove dipstick.
7. Check oil level on dipstick. Oil must be between ADD and FULL marks.
8. If oil level is low, add oil to bring oil level no higher than FULL mark on dipstick. Do not overfill.

SERVICE ENGINE

9. Install and tighten dipstick. Lower hood.

Changing Engine Oil and Filter

IMPORTANT: Avoid damage! Change the oil more often if the vehicle is used in extreme conditions:

- Extremely dusty conditions.
- Frequent slow or low-speed operation.
- Frequent short trips.

1. Run engine to warm oil.
2. Park machine safely. (See Parking Safely in the SAFETY section.)
3. Lift hood.
4. Put drain pan under drain valve.

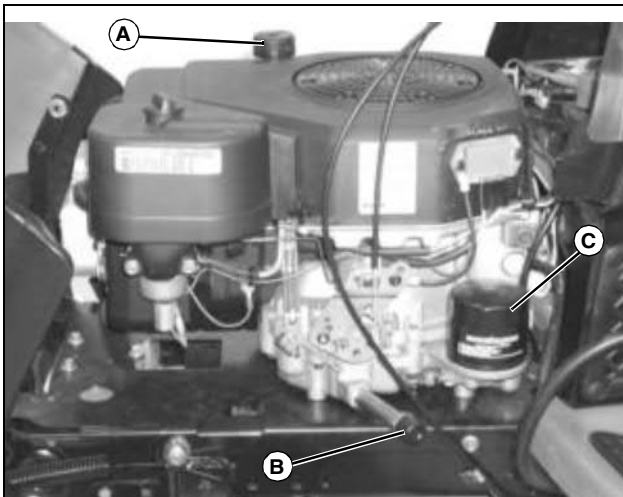

MX10525

Picture Note: Model with 17.5 hp engine shown.

5. Rotate and remove drain cap (B) and drain oil into oil drain pan. Allow oil to drain completely.
6. Remove dipstick (A).
7. Replace oil filter (C), if equipped.
 - a. Wipe dirt from around oil filter (C).
 - b. Place a drain pan or funnel under filter tray.
 - c. Remove old filter and wipe off filter tray.
 - d. Put a light coat of fresh, clean oil on the filter gasket.
 - e. Install replacement oil filter by turning oil filter to the right (clockwise) until the rubber gasket contacts filter base. Tighten filter an additional one-half turn.
8. Install drain cap.
9. Add oil no higher than FULL mark on dipstick. Use approximately the amount of oil listed in the Specifications

section. Do not overfill.

10. Install dipstick.

11. Start and run engine at idle to check for leaks. Stop engine. Fix any leaks before operating.

12. Check oil level, add oil if necessary.

Cleaning Air Intake Screen and Engine Fins

IMPORTANT: Avoid damage! The engine is air-cooled and requires a large amount of air intake when running. Reduced air intake can cause overheating:

- Keep air intake screen and cooling fins clean.
- Keep covers and screens in place.

1. Park machine safely. (See Parking Safely in the SAFETY section.)

2. Lift hood.

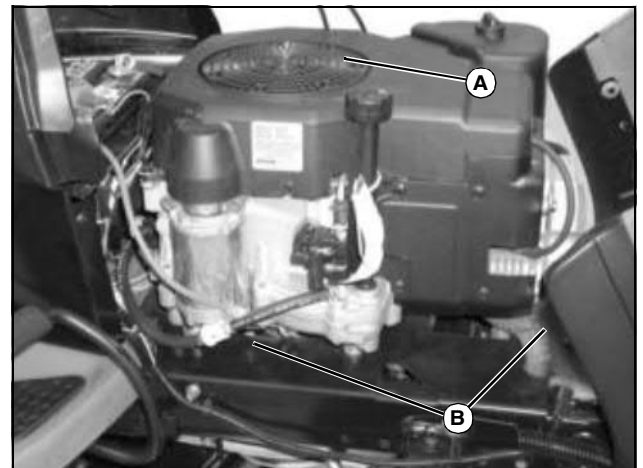

MX10526

Picture Note: Model with 17.5 hp engine shown.

3. Clean air intake screen (A), cooling fins and external surfaces (B), with rag, brush, vacuum or compressed air.
4. Lower hood.

Checking and Cleaning Air Cleaner Elements (17 hp Briggs and Stratton)

1. Park machine safely. (See Parking Safely in the SAFETY section.)

SERVICE ENGINE

CAUTION: Avoid injury! Touching hot surfaces can burn skin. The engine, components, and fluids will be hot if the engine has been running. Allow the engine to cool before servicing or working near the engine and components.

2. Let engine cool.
3. Lift hood.
4. Clean dirt and debris from the air cleaner cover.

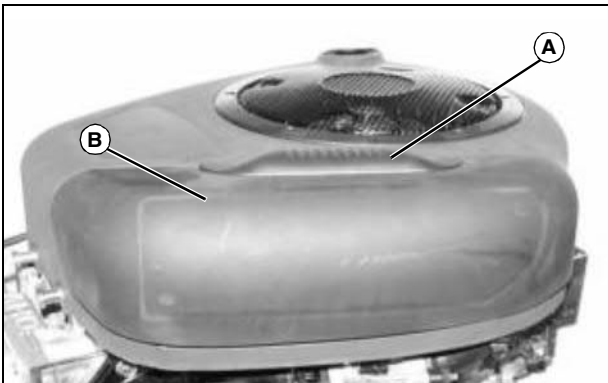

MX7680

5. Lift latch (A) to unlock cover (B). Lift cover forward and remove.

IMPORTANT: Avoid damage! Dirt and debris can enter the engine through a damaged filter element:

- Do not wash paper element.
- Do not attempt to clean paper element by tapping against another object.
- Do not use pressurized air to clean element.
- Replace element only if it is very dirty, damaged or the seal is cracked.

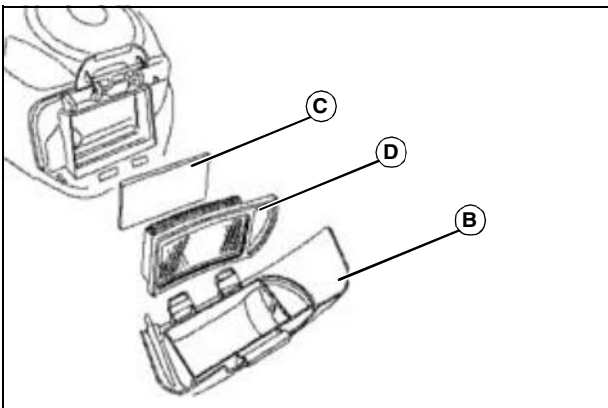

MX7679

6. Inspect the foam precleaner (C) without removing it. If the foam precleaner is dirty:

- a. Remove it from the filter carefully, leaving the paper element (D) in the air cleaner housing.

- b. Wash precleaner in a solution of warm water and liquid detergent. Do not use oil.

- c. Rinse precleaner thoroughly. Squeeze out excess water in a dry cloth until precleaner is completely dry.

7. Inspect the paper filter element (D) without removing it. If the paper filter element is damaged or dirty:

- Carefully remove the element from the air cleaner housing.

8. Clean air cleaner base very carefully, preventing any dirt from falling into carburetor.

9. Install new paper filter element.

10. Install foam precleaner on paper filter element.

11. Install air cleaner cover and push latch down to lock.

12. Lower hood.

Checking and Cleaning Air Cleaner Elements (17.5hp Kohler Engine)

1. Park machine safely. (See Parking Safely in the SAFETY section.)

CAUTION: Avoid injury! Touching hot surfaces can burn skin. The engine, components, and fluids will be hot if the engine has been running. Allow the engine to cool before servicing or working near the engine and components.

2. Let engine cool.

3. Lift hood.

4. Clean dirt and debris from the air cleaner cover.

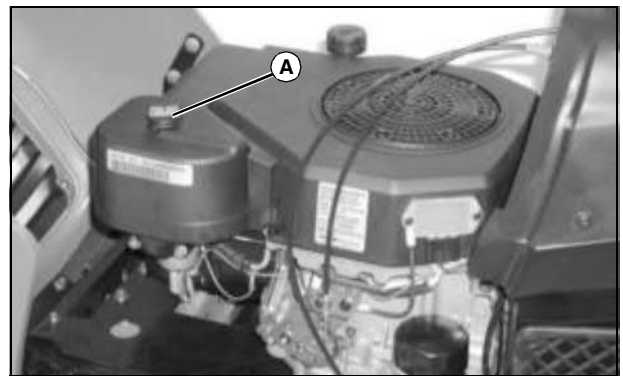

MX7687

5. Loosen knob (A) and remove cover.

SERVICE ENGINE

IMPORTANT: Avoid damage! Dirt and debris can enter the engine through a damaged filter element:

- Do not wash paper element.
- Do not attempt to clean paper element by tapping against another object.
- Do not use pressurized air to clean element.
- Replace element only if it is very dirty, damaged or the seal is cracked.

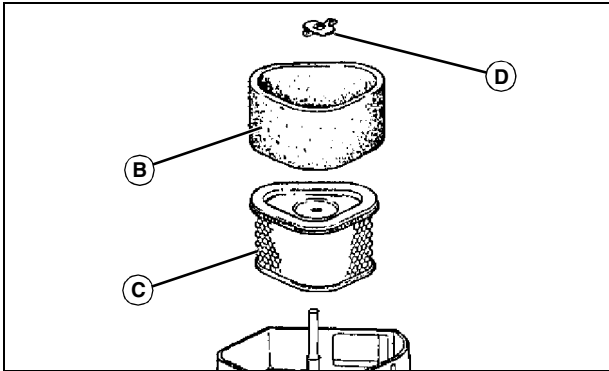

MX8392

Checking and Cleaning Air Cleaner Elements (20hp Briggs and Stratton)

1. Park machine safely. (See Parking Safely in the SAFETY section.)



CAUTION: Avoid injury! Touching hot surfaces can burn skin. The engine, components, and fluids will be hot if the engine has been running. Allow the engine to cool before servicing or working near the engine and components.

2. Let engine cool.
3. Lift hood.
4. Clean dirt and debris from the air cleaner cover.

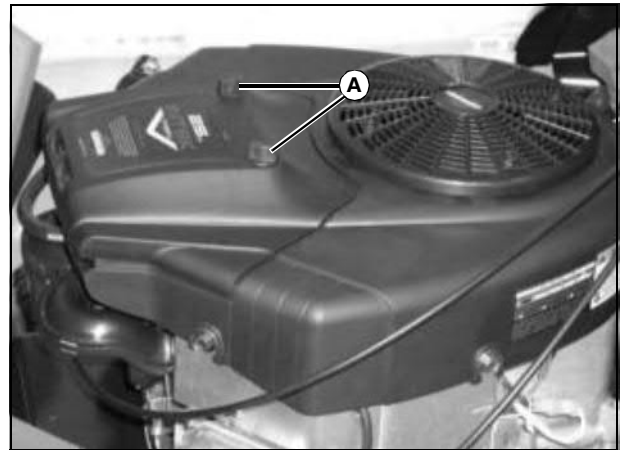

MX7682

5. Loosen knobs (A) and remove cover.

6. Inspect the foam pre-cleaner (B) without removing it. If the foam pre-cleaner is dirty:
 - a. Remove it from the filter carefully, leaving the paper element (C) in the air cleaner housing.
 - b. Wash pre-cleaner in a solution of warm water and liquid detergent.
 - c. Rinse pre-cleaner thoroughly. Squeeze out excess water in a dry cloth until pre-cleaner is completely dry.
 - d. Put approximately 30 ml. (1 oz) of clean engine oil onto the pre-cleaner. Squeeze pre-cleaner to distribute the oil evenly. Squeeze out excess oil with a clean cloth.
7. Inspect the paper filter element (C) without removing it. If the element is damaged or dirty:
 - a. Remove wing nut (D).
 - b. Carefully remove the element from the air cleaner housing.
 - c. Clean air cleaner base very carefully, preventing any dirt from falling into carburetor.
 - d. Install new paper filter element into air cleaner. Make sure element is seated properly.
 - e. Install wing nut.
8. Install pre-cleaner on paper element.
9. Install air cleaner cover. Do not overtighten.
10. Lower hood.

SERVICE ENGINE

IMPORTANT: Avoid damage! To prevent engine damage, do not allow any foreign objects to fall into the carburetor air intake.

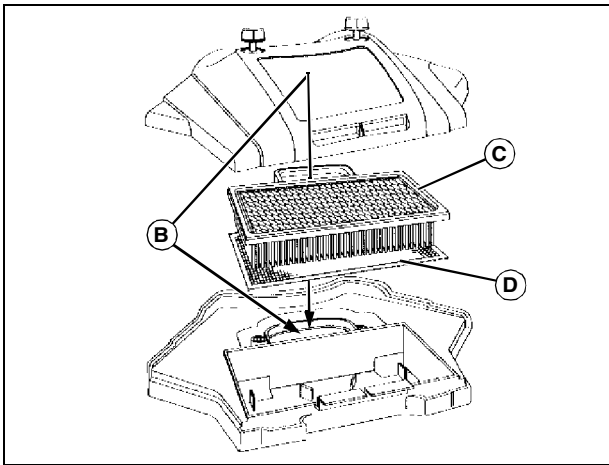

M96094

6. Do not drop anything into the carburetor air intake (B). If anything falls into the carburetor air intake it must be removed.

7. Lift out filter cartridge (C) and inspect it for damage.

IMPORTANT: Avoid damage! Dirt and debris can enter the engine through a damaged filter element:

- Do not wash paper element.
- Do not attempt to clean paper element by tapping against another object.
- Do not use pressurized air to clean element.
- Replace element only if it is very dirty, damaged or the seal is cracked.

8. Inspect the foam pre-cleaner without removing it. If the foam pre-cleaner (D) is dirty:

- Remove it from the filter carefully.
- Wash pre-cleaner in a solution of warm water and liquid detergent.
- Rinse pre-cleaner thoroughly. Squeeze out excess water in a dry cloth until pre-cleaner is completely dry.

9. Clean air cleaner housing carefully. Prevent any dirt from falling into carburetor.

10. Install foam pre-cleaner mesh side up.

11. Install cartridge. Make sure cartridge and seal are properly seated and sealing the carburetor air intake area.

12. Install air cleaner cover and tighten knobs. Do not overtighten.

13. Lower hood.

Checking and Cleaning Air Cleaner Elements (23hp Kohler)

1. Park machine safely. (See Parking Safely in the SAFETY section.)



CAUTION: Avoid injury! Touching hot surfaces can burn skin. The engine, components, and fluids will be hot if the engine has been running. Allow the engine to cool before servicing or working near the engine and components.

2. Let engine cool.

3. Lift hood.

4. Clean dirt and debris from the air cleaner cover.



MX13509

5. Unhook latches on both sides of cover (A) and remove cover.

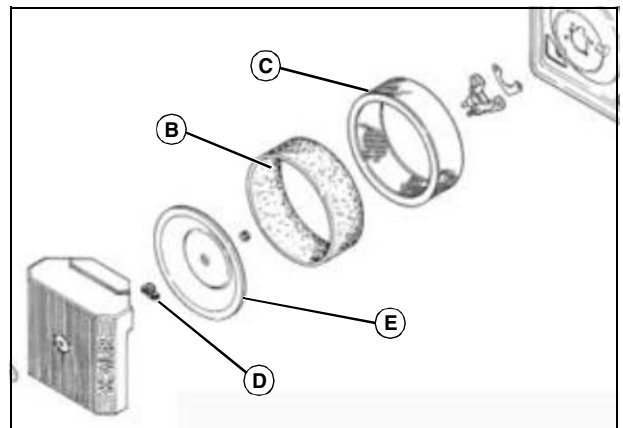

M88594

6. Inspect the foam pre-cleaner (B) without removing it. If the foam pre-cleaner is dirty:

- Remove it from the filter carefully, leaving the paper element (C) in the air cleaner housing.
- Wash pre-cleaner in a solution of warm water and liquid detergent.

SERVICE ENGINE

- c. Rinse precleaner thoroughly. Squeeze out excess water in a dry cloth until precleaner is completely dry.
- d. Put approximately 30 ml. (1 oz) of clean engine oil onto the precleaner. Squeeze precleaner to distribute the oil evenly. Squeeze out excess oil with a clean cloth.

IMPORTANT: Avoid damage! Dirt and debris can enter the engine through a damaged filter element:

- Do not wash paper element.
- Do not attempt to clean paper element by tapping against another object.
- Do not use pressurized air to clean element.
- Replace element only if it is very dirty, damaged or the seal is cracked.

7. Inspect the paper filter element without removing it. If the paper filter element (C) is damaged or dirty:
 - Remove knob (D) and plate (E).
 - Carefully remove the element from the air cleaner housing.
 - Clean air cleaner base very carefully, preventing any dirt from falling into carburetor.
 - Install new paper filter element, plate and knob.
8. Install foam precleaner on paper filter element.
9. Install cover and attach clips to body.
10. Lower hood.

Checking Spark Plug

1. Park machine safely. (See Parking Safely in the SAFETY Section.)



CAUTION: Avoid injury! Touching hot surfaces can burn skin. The engine, components, and fluids will be hot if the engine has been running. Allow the engine to cool before servicing or working near the engine and components.

2. Let engine cool.
3. Lift hood.



MX10526

Picture Note: Model with 17.5 hp engine shown.

4. Disconnect spark plug wire(s) (A), one on each side on V-twin engines.
5. Remove spark plug(s).
6. Clean spark plug carefully with a wire brush.
7. Inspect spark plug for:
 - Cracked porcelain.
 - Pitted or damaged electrodes.
 - Other wear or damage.

NOTE: In Canada, replace spark plug with resistor plug only.

8. Replace spark plug as necessary.

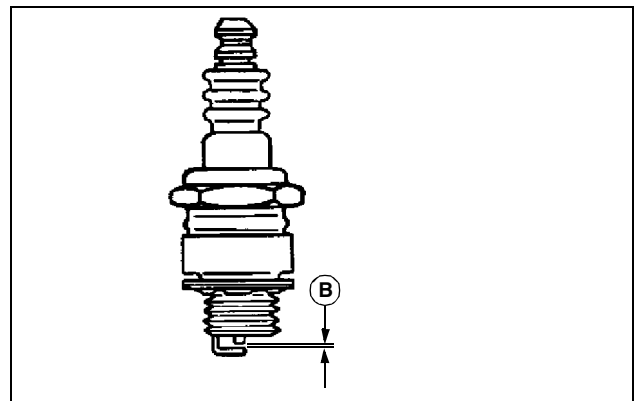

M85200

9. Check plug gap (B) with a wire feeler gauge. To change gap, move the outer electrode.
 - Gap must be 0.76 mm (0.030 in.).
10. Install and tighten spark plugs to 20 N•m (15 lb-ft).
11. Connect spark plug wires and lower hood.

SERVICE ENGINE

Adjusting Carburetor

NOTE: Carburetor is calibrated by the engine manufacturer and is not adjustable.

If engine is operated at altitudes above 1829 m (6,000 ft), some carburetors may require a special high altitude main jet. See your authorized dealer.

If engine is hard to start or runs rough, check the troubleshooting section of this manual.

Possible engine surging will occur at high throttle with transmission in "N" neutral and mower engagement lever disengaged. This is a normal condition due to the emission control system.

After performing the checks in the troubleshooting section and your engine is still not performing correctly, contact your authorized dealer.

Replacing Fuel Filter



CAUTION: Avoid injury! Fuel vapors are explosive and flammable:

- Do not smoke while handling fuel.
- Keep fuel away from flames or sparks.
- Shut off engine before servicing.
- Cool engine before servicing.
- Work in a well-ventilated area.
- Clean up spilled fuel immediately.

NOTE: Change filter when fuel is low.

1. Park machine safely. (See Parking Safely in the SAFETY section.)



CAUTION: Avoid injury! Touching hot surfaces can burn skin. The engine, components, and fluids will be hot if the engine has been running. Allow the engine to cool before servicing or working near the engine and components.

2. Let engine cool.
3. Lift hood.
4. Put a drain pan under fuel filter.

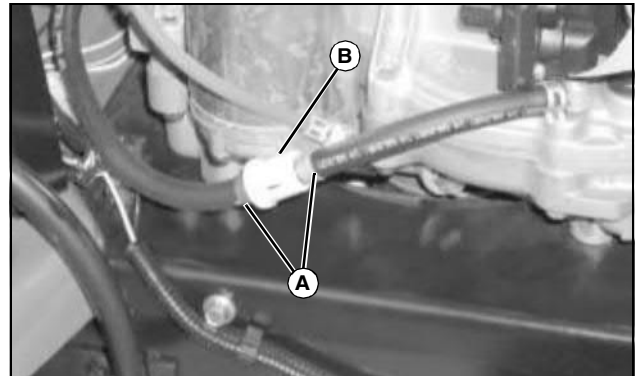

MX7685

Picture Note: Model with 17.5 hp engine shown.

5. Slide hose clamps (A) away from fuel filter (B) using a pliers.
6. Disconnect hoses from filter.

IMPORTANT: Avoid damage! Incorrect installation of fuel filter may cause engine damage. Install the filter with the arrow pointing in the direction of fuel flow for proper operation.

7. Connect hoses to new filter making sure the filter arrow is pointed in the direction of the fuel flow.
8. Install clamps and check for leaks.
9. Lower hood.

SERVICE TRANSMISSION

Checking Transmission

The transmission is a sealed component. No maintenance is required on this transmission. If you suspect any transmission problems, please contact your authorized dealer.

SERVICE MOWER

Installing or Removing Mower Drive Belt at Engine Drive Sheave (122 cm (48 in.) Deck)

NOTE: This procedure is for easy installing and removing.



MX10523Y

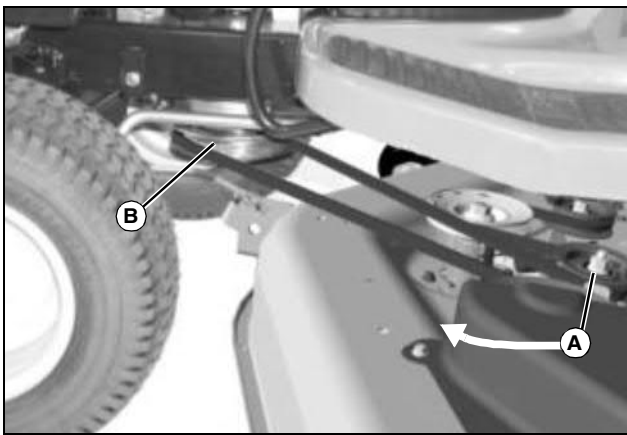

MX10520Y

1. Put lift lever in lowest position.
2. Put a 15mm closed wrench or a socket on the idler sheave nut (A), move idler sheave toward front of tractor and hold to release belt tension.
3. Install the belt on the drive sheave (B).
4. Release idler sheave to tighten belt.
5. Use same procedure to remove belt.

Removing Mower

1. Park machine safely. (See Parking Safely in SAFETY section.)
2. Put wood blocks under each side of mower deck.
3. Put lift lever in lowest position, bringing deck down onto blocks.



CAUTION: Avoid injury! Rotating blades are dangerous. Before adjusting or servicing mower:

- Disconnect spark plug wire(s) or battery negative (-) cable to prevent engine from starting accidentally.
- Always wear gloves when handling mower blades or working near blades.

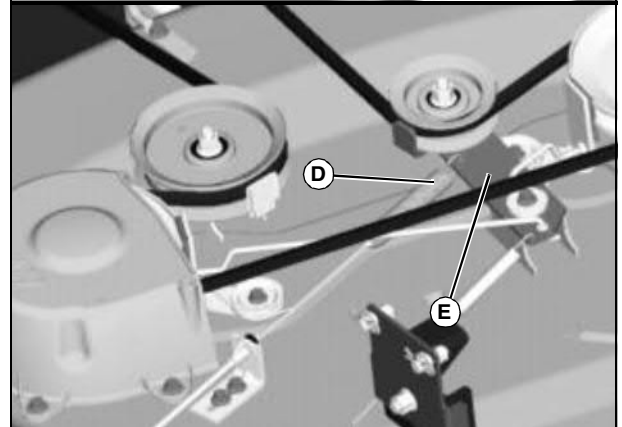
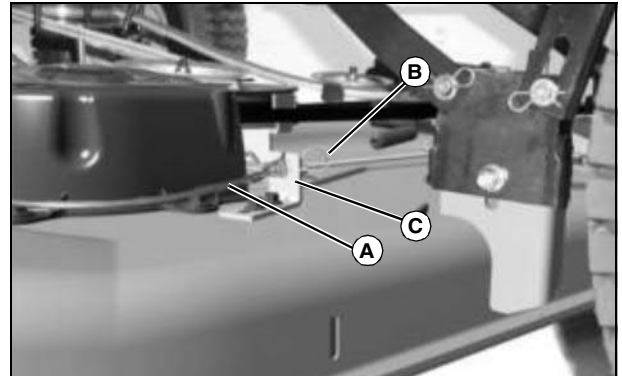

MX10517Y; MX7681

Picture Note: 107 cm (42 in.) only.

4. On machines with 107 cm (42 in.), disconnect PTO drive cable (A).
 - a. Remove spring locking pin (B), pull and hold PTO drive cable out, lift up and remove from bracket (C).
 - b. Remove cable spring (D) from idler sheave bracket (E).

SERVICE MOWER

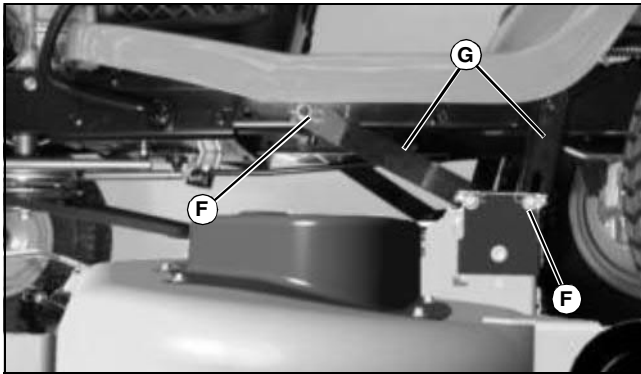

MX10516Y

5. Remove spring locking pins and washers (F) and disconnect rear draft arms (G), two on each side.

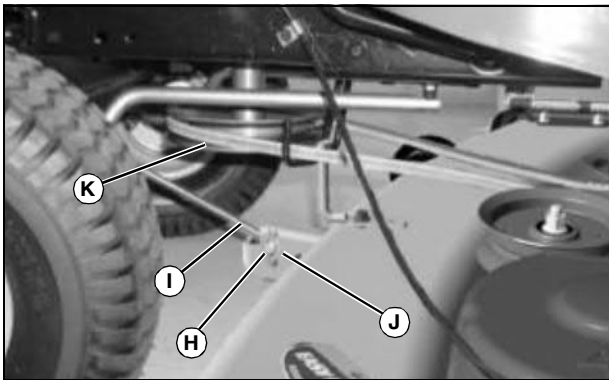

MX10521Y

Picture Note: 107 cm (42 in.) shown.

6. Remove spring locking pin and washer (H) and front draft rod (I) from mower deck bracket (J).
7. Remove mower drive belt from drive sheave (K).
8. Remove wood blocks from both sides and slide mower out from under the machine.
9. When operating the machine without the mower deck:

- Remove rear draft arms and front draft rod from tractor and attach them to the mower deck.

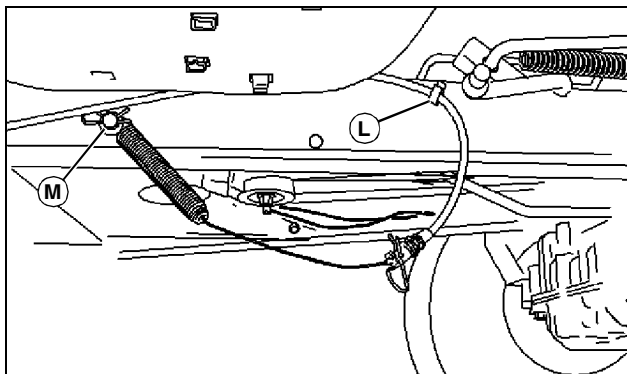

MX10514

- On 107 cm (42 in.) only: Push PTO drive cable into

clip (L) and hook end of cable spring with hardware (M) into peg on left side of machine frame.

Installing Mower

1. Park machine safely. (See Parking Safely in SAFETY section.)



CAUTION: Avoid injury! Rotating blades are dangerous. Before adjusting or servicing mower:

- Disconnect spark plug wire(s) or battery negative (-) cable to prevent engine from starting accidentally.
- Always wear gloves when handling mower blades or working near blades.

2. Put lift lever in the transport position.
3. Slide mower under machine.
4. Put wood blocks under each side of mower deck.
5. Put lift lever in lowest position.

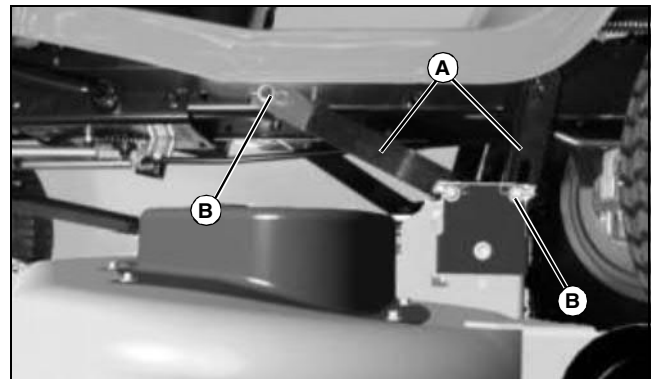

MX10516Y

6. Fasten rear draft arms (A), two on each side, with washers and spring locking pins (B).

SERVICE MOWER

IMPORTANT: Avoid damage! To prevent clutch damage, make sure front draft rod is installed correctly. Secure rod with washer and spring locking pin on the left side of mower deck bracket.

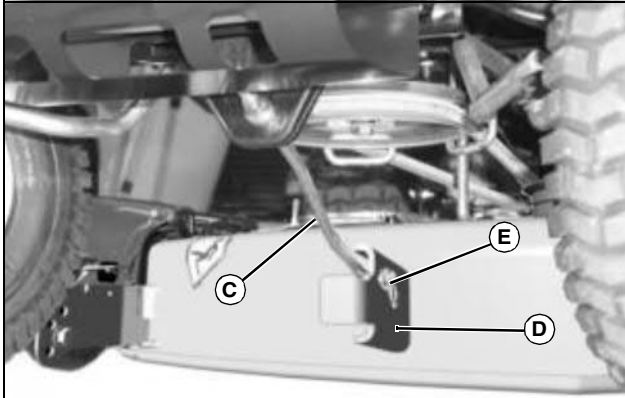

MX10529AY

Picture Note: 107 cm (42 in.) used for photo purposes.

7. Install front draft rod (C) into mower deck bracket (D) and secure with washer and spring locking pin (E) on the left side of bracket as shown.

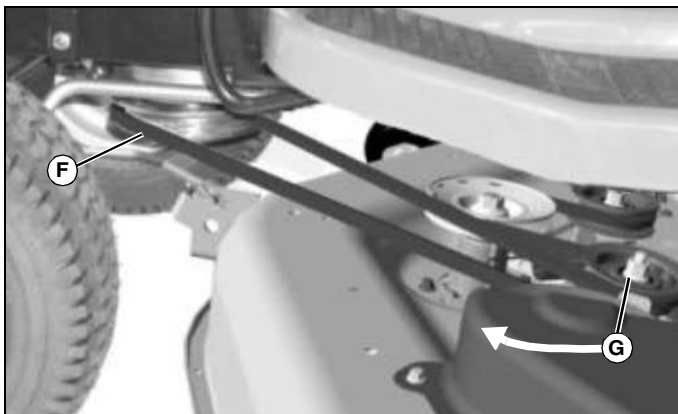

MX10520Y

Picture Note: 122 cm (48 in.) used for photo purposes.

8. Put mower drive belt on engine drive sheave (F).

- On 122 cm (48 in.): Move idler sheave (G) and tensioning arm toward front of tractor and hold while installing belt on drive sheave.

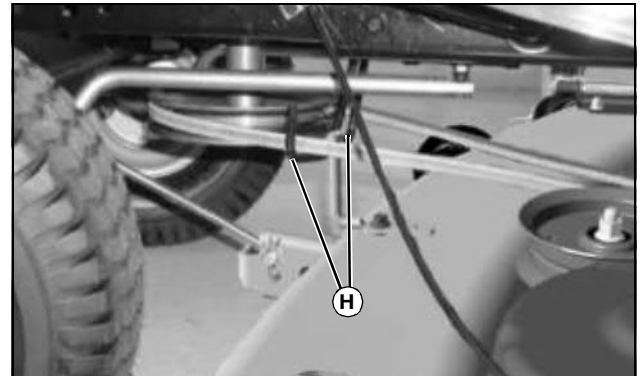

MX10521Y

- On 107 cm (42 in.): Make sure belt is routed through both belt guides (H).

9. Remove wood blocks from both sides of mower deck.

10. On machines with 107 cm (42 in.): Attach PTO drive cable.

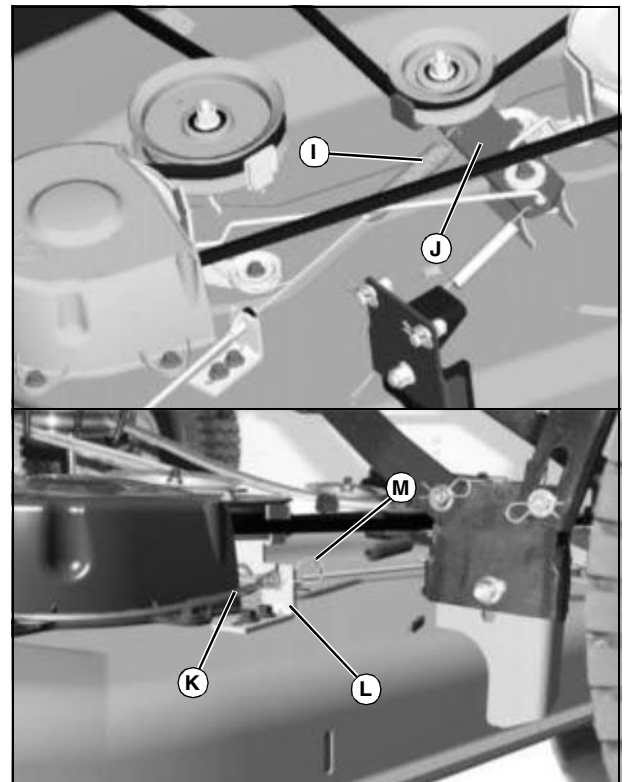

MX7681; MX10517Y

Picture Note: 107 cm (42 in.) only.

- Route cable under mower belt and brake rod and attach cable spring (I) to idler sheave bracket (J).
- Pull out on cable (K), align black end of cable with slot in bracket (L) and release cable into slot. Secure with spring locking pin (M).

11. Level mower.

SERVICE MOWER

Replacing Mower Drive Belt (107 cm (42 in.) Deck)



CAUTION: Avoid injury! Rotating blades are dangerous. Before adjusting or servicing mower:

- Disconnect spark plug wire(s) or battery negative (-) cable to prevent engine from starting accidentally.
- Always wear gloves when handling mower blades or working near blades.

1. Park machine safely. (See Parking Safely in the SAFETY section.)
2. Remove mower deck.
3. Remove drive belt.

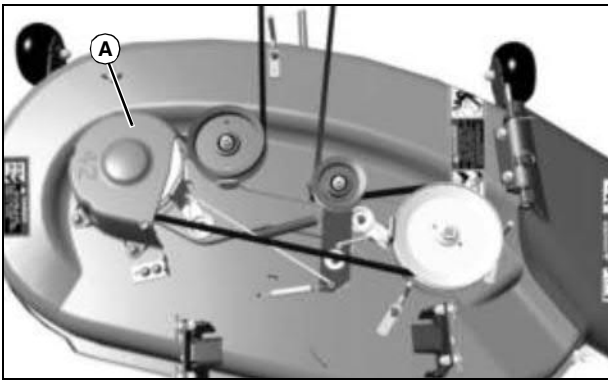

MX10511

- a. Remove three capscrews and belt shield (A).

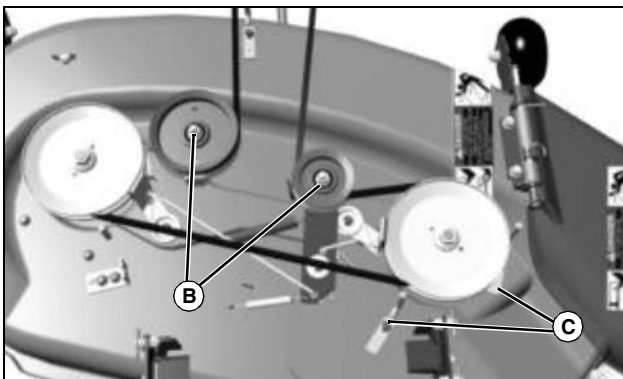

MX10512

- b. Loosen sheaves (B) and belt guides (C).
 - c. Remove mower belt.
4. Inspect belt for wear or damage; replace as necessary.
 5. Clean top surface of mower deck and sheaves.
 6. Install belt on mower deck as shown. Make sure belt is in the groove of each sheave and inside belt guides (C).

7. Tighten sheaves to 47 N•m (35 lb-ft).
8. Install belt shield.
9. Install mower deck.
10. Adjust mower belt tension and spindle brakes, if necessary.

Replacing Mower Drive Belt (122 cm (48 in.) Deck)



CAUTION: Avoid injury! Rotating blades are dangerous. Before adjusting or servicing mower:

- Disconnect spark plug wire(s) or battery negative (-) cable to prevent engine from starting accidentally.
- Always wear gloves when handling mower blades or working near blades.

1. Park machine safely. (See Parking Safely in SAFETY section.)
2. Remove mower deck.
3. Remove drive belt.

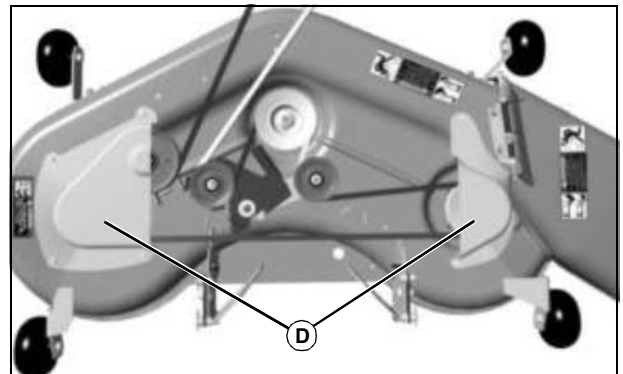

MX10505

- a. Remove seven capscrews and left and right belt shields (D).

SERVICE MOWER

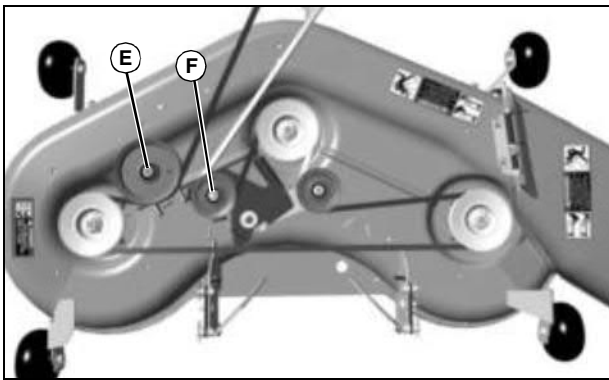

MX10506

- b. Loosen sheaves (E) and (F).
- c. Remove mower belt.
4. Inspect belt for wear or damage; replace as necessary.
5. Clean top surface of mower deck and sheaves.
6. Install belt on mower deck as shown. Make sure belt is in the groove of each sheave.
7. Tighten sheaves to 47 N•m (35 lb-ft).
8. Install belt shield(s).
9. Install mower deck.

Adjusting Mower Belt Tension (107 cm (42 in.) Deck)

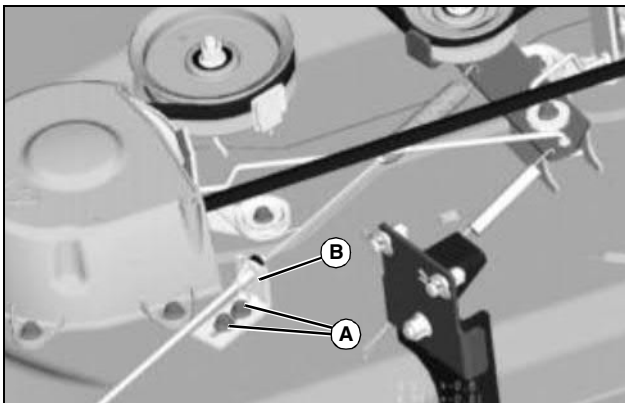

MX7681

1. Park machine safely. (See Parking Safely in the SAFETY section.)
2. Loosen nuts (A) and move cable bracket (B) away from the center of deck to tighten belt tension. Tighten nuts.

Adjusting Spindle Brakes (107 cm (42 in.) Deck)



CAUTION: Avoid injury! The mower blades should stop in approximately five seconds when the mower or PTO is disengaged.

If you believe that your blades may not be stopping in that period of time, take your machine to your authorized dealer where they can safely check and service your machine.

IMPORTANT: Avoid damage! Avoid belt damage.

Spindle brake engagement should be checked and corrected every time the mower belt tension is adjusted.

Mower belt tension should be adjusted, if required, before brakes are adjusted.

1. Park machine safely. (See Parking Safely in the SAFETY section.)
2. Remove mower deck.

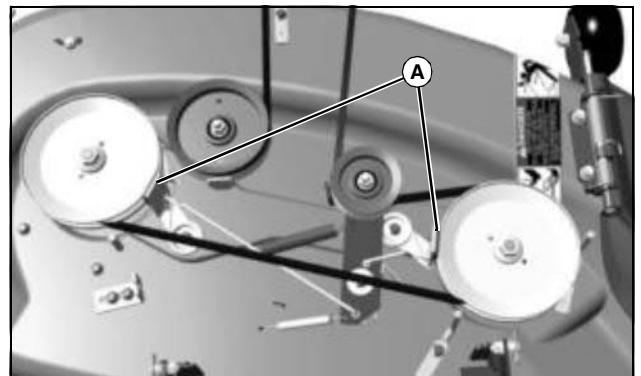

MX10512

3. Remove left belt shield and adjust two blade brakes (A).

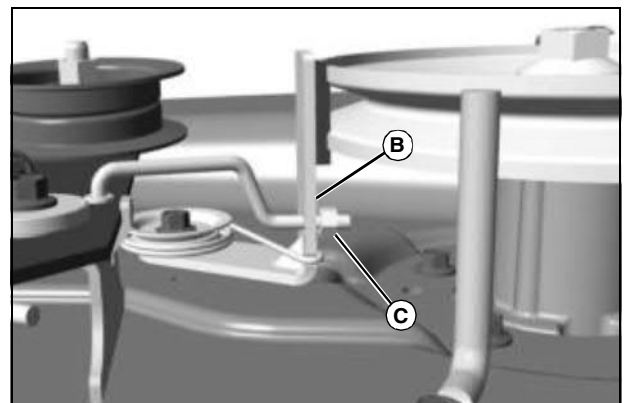

MX10507

4. Measure distance from spindle brake bracket (B) to nut (C) on end of brake rod.

SERVICE MOWER

- Bracket to nut distance should be: 2 – 3 mm (0.08 – 0.12 in).

5. If adjustment is required, turn nut (C) on end of brake rod in correct direction to set brake at proper distance from pulley.
6. Adjust both brakes.
7. Install left belt shield.
8. Install mower deck.

Checking for Bent Mower Blades



CAUTION: Avoid injury! Mower blades are sharp. Always wear gloves when handling mower blades or working near blades.

Replace blades if defective. Never straighten or weld them.

1. Park machine safely. (See Parking Safely in the SAFETY section.)
2. Raise mower to highest position to access blades.

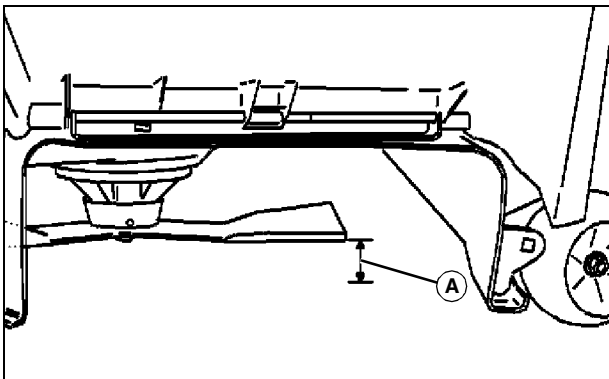

MX4897

Picture Note: Mower deck with side discharge used for illustration.

3. Measure distance (A) between blade tip and flat ground surface.
4. Rotate blade 180° and measure distance between other blade tip and flat ground surface.
5. Install new blade if the difference between the two measurements is more than 3 mm (1/8 in.).
6. Repeat for all blades.

Servicing Mower Blades



CAUTION: Avoid injury! Rotating blades are dangerous. Before adjusting or servicing mower:

- Disconnect spark plug wire(s) or battery negative (-) cable to prevent engine from starting accidentally.
- Always wear gloves when handling mower blades or working near blades.

Removing Mower Blades

1. Raise mower deck to gain access to mower blades. If necessary, remove mower deck.
2. Block mower blade with a piece of wood to prevent it from spinning.

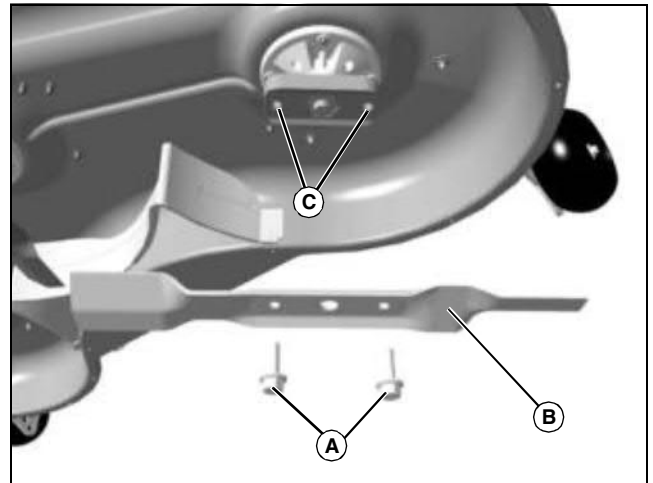

MX10510

3. Loosen and remove two cap screws (A) and blade (B). Do not remove two nuts/bushings (C) inside holes of the blade adapter.
4. Inspect blades; sharpen, balance or replace blades as necessary.

SERVICE MOWER

Installing Mower Blades

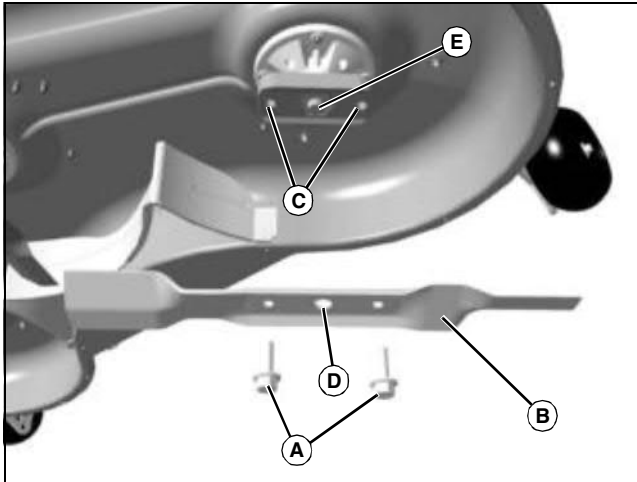

1. Make sure that two nuts/bushings (C) are in place.
2. Position mower blade (B) with the cutting edge towards the ground.
3. Align the center hole (D) in the blade with the spindle shaft (E) and put the blade onto the mower spindle.
4. Install and hand tighten cap screws (A) until mower blade is in full contact (fully seated) with spindle.
5. Block mower blade with a piece of wood to prevent spinning and tighten cap screws to 62 N•m (46 lb-ft).

Sharpening Blades



CAUTION: Avoid injury! Mower blades are dangerous!

- Always wear gloves while working on blades.
- Always wear safety eye protection when grinding.

- Sharpen blades with grinder, hand file, or electric blade sharpener.

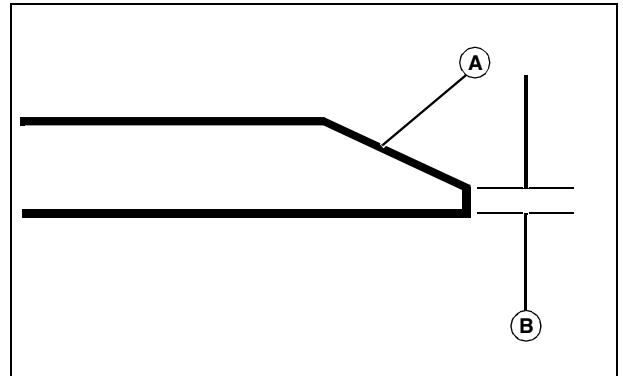

- Keep original bevel (A) when grinding.
- Blade should have 0.40 mm (1/64 in.) cutting edge (B) or less.
- Balance blades before installing.

Balancing Blades



CAUTION: Avoid injury! Mower blades are sharp. Always wear gloves when handling mower blades or working near blades.

1. Clean blade.

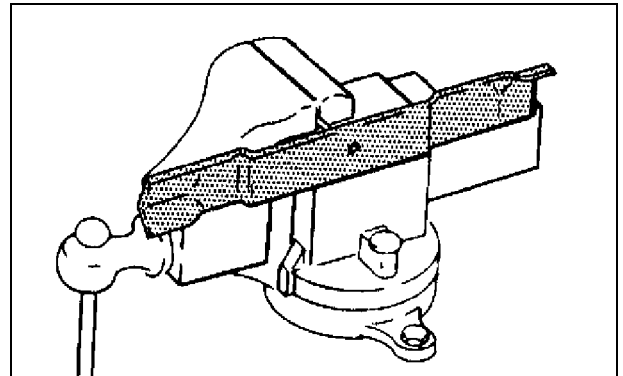

2. Put blade on nail in a vise. Turn blade to horizontal position.
3. Check balance. If blade is not balanced, heavy end of blade will drop.
4. Grind bevel of heavy end. Do not change blade bevel.

SERVICE ELECTRICAL

WARNING: Battery posts, terminals and related accessories contain lead and lead components, chemicals known to the State of California to cause cancer and reproductive harm. **Wash hands after handling.**

Service the Battery Safely



CAUTION: Avoid injury! The battery produces a flammable and explosive gas. The battery may explode:

- Do not smoke near battery.
- Wear eye protection and gloves.
- Do not allow direct metal contact across battery posts.
- Remove negative cable first when disconnecting.
- Install negative cable last when connecting.

Removing and Installing the Battery

Removing

1. Park machine safely and lift hood. (See Parking Safely in the SAFETY Section.)

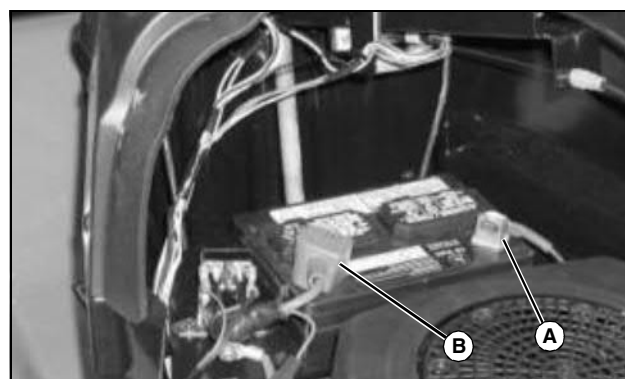

MX7686

2. Disconnect negative (-) battery cable (A).
3. Push red cover (B) away from positive (+) battery terminal and remove cable from battery.
4. Remove battery.

Installing

1. Place battery into battery tray.
2. Connect positive (+) cable to battery first, then negative (-) cable.
3. Apply general purpose grease or silicone spray to terminal to help prevent corrosion.
4. Slide red cover over positive battery terminal.

Cleaning Battery and Terminals

1. Park machine safely. (See Parking Safely in the SAFETY section.)
2. Disconnect and remove battery.
3. Wash battery with solution of four tablespoons of baking soda to one gallon of water. Be careful not to get the soda solution into the cells.
4. Rinse the battery with plain water and dry.
5. Clean terminals and battery cable ends with wire brush until bright.
6. Apply petroleum jelly or silicone spray to terminal to prevent corrosion.
7. Install battery.

SERVICE ELECTRICAL

Using Booster Battery

CAUTION: Avoid injury! The battery produces a flammable and explosive gas. The battery may explode:

- Do not attempt to jump start a frozen battery. Warm to 16 degrees C (60 degrees F).
- Do not smoke near battery.
- Wear eye protection and gloves.
- Keep sparks and flames away.
- Do not connect the negative (-) booster cable to the negative (-) terminal of the discharged battery. Connect at a good ground location away from the discharged battery.

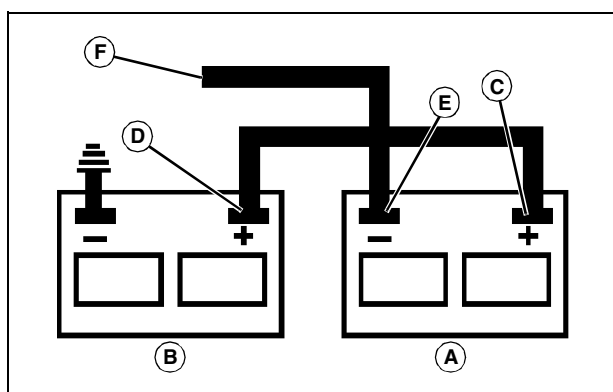

M71044

A - Booster Battery

B - Disabled Vehicle Battery

1. Connect positive (+) booster cable to booster battery (A) positive (+) post (C).
2. Connect the other end of positive (+) booster cable to the disabled vehicle battery (B) positive (+) post (D).
3. Connect negative (-) booster cable to booster battery negative (-) post (E).

IMPORTANT: Avoid damage! Electric charge from booster battery can damage machine components. Do not install negative booster cable to machine frame. Install only to the engine block.

Install negative booster cable away from moving parts in the engine compartment, such as belts and fan blades.

4. Connect the other end (F) of negative (-) booster cable to a metal part of the disabled machine engine block away from battery.
5. Start the engine of the disabled machine and run

machine for several minutes.

6. Carefully disconnect the booster cables in the exact reverse order: negative cable first and then the positive cable.

Replacing Headlight Bulb

1. Park machine safely. (See Parking Safely in the SAFETY section.)
2. Lift hood.

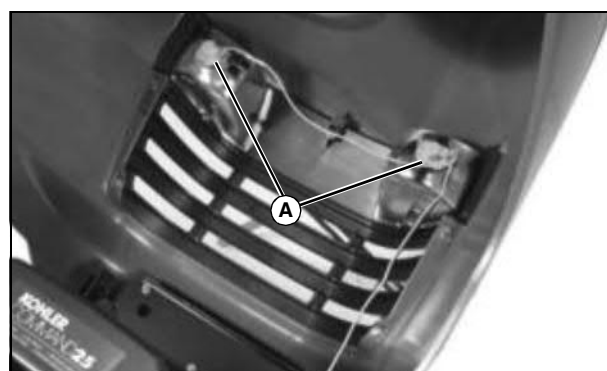

MX17057

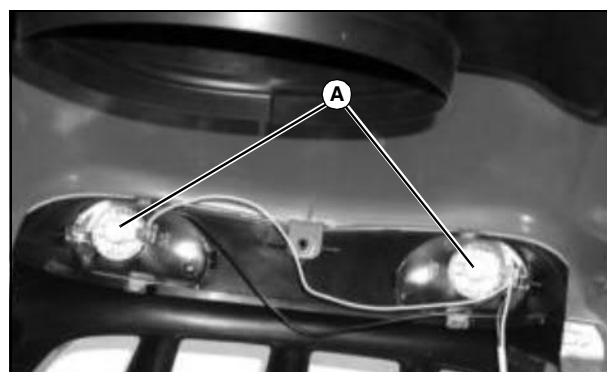

MX10504

3. Turn bulb socket (A) 1/4 turn counterclockwise to remove.
4. Replace defective bulb with a new bulb.
5. Insert bulb socket into housing, push in and turn 1/4 turn clockwise to install.
6. Lower hood.

Replacing Fuse

1. Park machine safely. (See Parking Safely in the SAFETY section.)
2. Lift hood.

SERVICE ELECTRICAL



MX17056

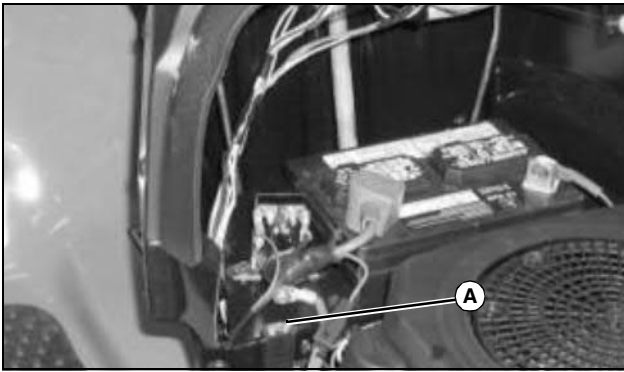

MX7686

3. Pull defective fuse (A) out of socket.
4. Check metal clip in fuse window and discard fuse if clip is broken.
5. Push new 20 amp fuse into socket.
6. Lower hood.

SERVICE MISCELLANEOUS

Using Proper Fuel

Use regular grade unleaded fuel with an octane rating of 87 octane or higher. Fuel blends containing up to 10% ethanol or up to 15% MTBE reformulated fuel are acceptable. Do not use fuel or additives containing methanol as engine damage can occur.

Always use fresh, clean fuel that is purchased in a quantity that can be used within approximately 30 days, or add fuel stabilizer.

Fuel is blended to give best seasonal performance. To avoid engine performance problems such as hard starting or vapor lock, use in-season fuel. Use fuel during warm weather that was purchased during that season, and use fuel during cold weather that was purchased during that season.

Fuel can become stale in machines with engines that are used seasonally or infrequently during a season. Stale fuel can produce varnish and plug carburetor or injector components which can affect engine performance.

Keep fuel storage container tightly covered and in a cool area out of direct sunlight. Fuel can break down and degrade if not sealed properly or exposed to sun and heat.

Condensation may collect in the fuel tank because of a variety of operating or environmental conditions and, over time, may affect your machine's operation. Fill fuel tank at the end of daily use and store fuel in plastic containers to reduce condensation.

For best year-round performance and fuel-handling, add stabilizer to fuel immediately after fuel purchase. Such practice helps prevent engine performance problems and allows fuel storage in the machine all year without draining.

Filling Fuel Tank



CAUTION: Avoid injury! Fuel vapors are explosive and flammable:

- Shut engine off before filling fuel tank.
- Do not smoke while handling fuel.
- Keep fuel away from flames or sparks.
- Fill fuel tank outdoors or in well ventilated area.
- Clean up spilled fuel immediately.
- Use clean approved non-metal container to prevent static electric discharge.
- Use clean approved plastic funnel without screen or filter to prevent static electric discharge.

IMPORTANT: Avoid damage! Dirt and water in fuel can cause engine damage:

- Clean dirt and debris from the fuel tank opening.
- Use clean, fresh, stabilized fuel.
- Fill the fuel tank at the end of each day's operation to keep condensation out of the fuel tank.
- Use a non-metallic funnel with a plastic mesh strainer when filling the fuel tank or container.

Fill fuel tank at the end of each day's operation to prevent condensation and freezing during cold weather.

1. Park machine safely. (See Parking Safely in the SAFETY section.)
2. Allow engine to cool.
3. Remove any trash from area around fuel tank cap.
4. Remove fuel tank cap slowly to allow any pressure built up in tank to escape.
5. Fill fuel tank only to bottom of filler neck.
6. Install fuel tank cap.

Removing and Installing Hood

Removing



CAUTION: Avoid injury! Touching hot surfaces can burn skin. The engine, components, and fluids will be hot if the engine has been running. Allow the engine to cool before servicing or working near the engine and components.

IMPORTANT: Avoid damage! Do not operate machine with hood open. Hood must be closed for proper engine cooling and exhaust.

1. Park machine safely. (See Parking Safely in the SAFETY section.)
2. Let engine cool.

SERVICE MISCELLANEOUS

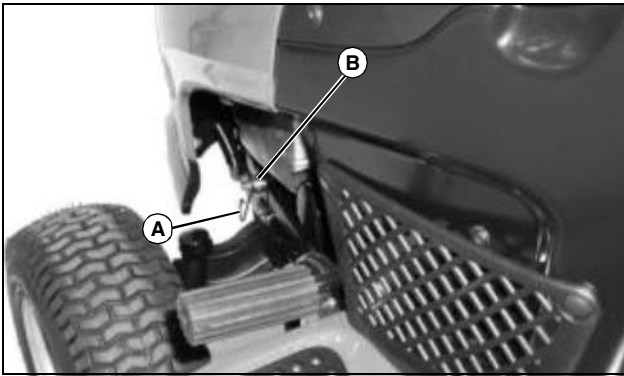

MX10518

3. Keep hood in the closed position and pull spring hook (A) towards rear of tractor and remove from bolt (B), one on each side.

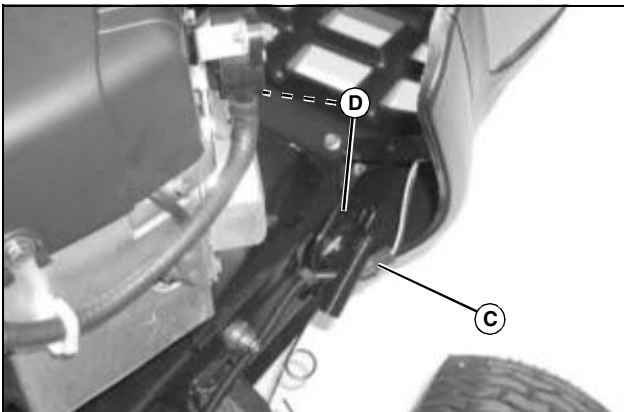

MX10519

4. Open hood.
5. Disconnect wiring harness (C).
6. Lower hood slightly and lift hood from brackets (D).

Installing

1. Align hood brackets with tractor brackets and install hood.
2. Connect wiring harness.
3. Close hood.
4. Pull spring hooks over bolts and release to secure hood.

Cleaning and Repairing Plastic Surfaces

Your authorized dealer has the professional materials needed to properly remove surface scratches from any plastic surfaces, do not attempt to paint over marks or scratches in plastic parts.

IMPORTANT: Avoid damage! Improper care of machine plastic surfaces can damage that surface:

- Do not wipe plastic surfaces when they are dry. Dry wiping will result in minor surface scratches.
- Use a soft, clean cloth (bath towel, diaper, automotive mitt).
- Do not use abrasive materials, such as polishing compounds, on plastic surfaces.
- Do not spray insect repellent near machine.

1. Rinse hood and entire machine with clean water to remove dirt and dust that may scratch the surface.
2. Wash surface with clean water and a mild liquid automotive washing soap.
3. Dry thoroughly to avoid water spots.
4. Wax the surface with a liquid automotive wax. Use products that specifically say "contains no abrasives."

IMPORTANT: Avoid damage! Do not use a power buffer to remove wax.

5. Buff applied wax by hand using a clean, soft cloth.

Cleaning and Repairing Metal Surfaces

Cleaning:

Follow automotive practices to care for your vehicle painted metal surfaces. Use a high-quality automotive wax regularly to maintain the factory look of your vehicle's painted surfaces.

Repairing Minor Scratches (surface scratch):

1. Clean area to be repaired thoroughly.

IMPORTANT: Avoid damage! Do not use rubbing compound on painted surfaces.

2. Use automotive polishing compound to remove surface scratches.
3. Apply wax to entire surface.

Repairing Deep Scratches (bare metal or primer showing):

1. Clean area to be repaired with rubbing alcohol or mineral spirits.
2. Use paint stick with factory-matched colors available from your authorized dealer to fill scratches. Follow directions included on paint stick for use and for drying.
3. Smooth out surface using an automotive polishing

SERVICE MISCELLANEOUS

compound. Do not use power buffer.

4. Apply wax to surface.

TROUBLESHOOTING

Using Troubleshooting Chart

If you are experiencing a problem that is not listed in this chart, see your authorized dealer for service.

When you have checked all the possible causes listed and you are still experiencing the problem, see your authorized dealer.

Engine

IF	CHECK
Poor Engine Performance	<p>Dirt in fuel system or fuel is old. Replace fuel with fresh stabilized fuel. Obtain fuel from another supplier before suspecting machine problems. Suppliers blend fuels differently and changing suppliers will generally solve any performance problems</p> <p>Fuel blended with alcohol or ether may contribute to performance problems by causing gum and varnish deposits, especially if fuel is stored for several weeks or more. Obtain fresh fuel.</p>
Engine Will Not Start	<p>Brake pedal not depressed.</p> <p>PTO is engaged.</p> <p>Spark plug wire is loose or disconnected.</p> <p>Improper fuel.</p> <p>Plugged fuel filter.</p> <p>Defective safety switch.</p> <p>Electrical problem - See Electrical Troubleshooting Section</p>
Engine Is Hard To Start	<p>Carburetor is not adjusted properly or dirty.</p> <p>Plugged fuel filter.</p> <p>Faulty spark plug.</p> <p>Stale or improper fuel.</p> <p>Loose or corroded electrical connections.</p> <p>Engine oil viscosity.</p>
Engine Runs Unevenly	<p>Cooling fins plugged.</p> <p>Loose electrical connections.</p> <p>Choke or throttle cable sticking.</p> <p>Fuel line or fuel filter plugged.</p> <p>Stale or dirty fuel.</p> <p>Improper fuel.</p> <p>Air cleaner element plugged.</p>
Engine Misses Under Load	<p>Faulty spark plug.</p> <p>Stale or dirty fuel.</p> <p>Plugged fuel filter.</p>

TROUBLESHOOTING

IF	CHECK
Engine Vapor Locks	Fuel tank vent plugged. Dirt in fuel filter. Cooling fins plugged. Loose hose connection at fuel filter or fuel pump.
Engine Overheats	Engine air intake screen plugged. Cooling fins plugged. Engine oil low or too high. Engine operated too long at a slow idle speed.
Engine Will Not Idle	Spark plug not gapped correctly. Faulty spark plug. Operator raising off the seat.
Engine Knocks	Stale or low octane fuel. Engine overloaded. Low engine speed. Oil level low.
Engine Stops Or Misses When Operating On Hillsides	Fuel tank less than half full of fuel. Operator raising off of the seat.
Engine Backfires	Faulty spark plug. Operator raising off of the seat.
Engine Loses Power	Engine overheating. Too much oil in engine. Dirty air cleaner. Faulty spark plug. Travel speed is too fast for conditions. Improper fuel.
Excessive Fuel Consumption	Choke is not fully open.
Black Exhaust Smoke	Air filter is dirty or oil soaked.
Engine Stops When REVERSE Foot Pedal Is Depressed And Attachment Is Engaged (Hydrostatic)	Normal condition. (See Using Reverse Implement Option in the OPERATING section.)
Engine Stops When Gear Shift Lever Is Moved To The R (REVERSE) Position and Attachment Is Engaged (Gear)	Normal condition. (See Using Reverse Implement Option in the OPERATING section.)

TROUBLESHOOTING

Electrical

IF	CHECK
Starter Does Not Work Or Will Not Turn Engine	Brake pedal is not depressed. PTO is engaged. Battery terminals are corroded. Battery not charged. Blown fuse. Fusible Link in starting circuit is blown - See your authorized dealer
Battery Will Not Charge	Dead cell in the battery. Battery cables and terminals are dirty. Low engine speed or excessive idling.
Lights Do Not Work	Light plug disconnected. Loose or burned out bulb.

Tractor

IF	CHECK
Tractor Vibrates Too Much Or Rattles Excessively	Attachment drive belts worn or damaged. Traction drive belt damaged or worn. Dirt on drive sheaves. Blades bent or out of balance.
Tractor Will Not Move With Engine Running	Parking brake locked. Free-wheeling lever is engaged.
Tractor Performance Becomes Slow or Jerky	Front wheels lift off ground more than 6 in. when quickly engaging drive in 5th gear--replace mower drive belt. (Gear)

Mower

IF	CHECK
Discharge Chute Plugged	Travel speed too fast. Grass too long. Grass too wet. Engine rpm not at wide open throttle. Restricted air flow. Belt installed incorrectly.

TROUBLESHOOTING

IF	CHECK
Patches Of Grass Uncut	Travel speed too fast. Engine rpm not at wide open throttle. Mower deck needs cleaning.
Belt Slipping	Debris in sheaves. Worn belt. Belt tension is incorrect.
Too Much Vibration	Debris on mower deck or in sheaves. Damaged drive belt. Damaged sheaves or sheaves out of alignment. Blades out of balance.
Blades Scalping Grass	Cutting too low. Mower wheels not adjusted correctly. Turning speed too fast. Ridges in terrain. Rough or uneven terrain. Low tire pressure.
Mower Loads Down Tractor	Engine rpm too low. Travel speed too fast. Debris wrapped around mower spindles.
Uneven Cut	Mower deck not leveled properly. Travel speed too fast. Blades dull. Mower wheels not adjusted correctly. Tire pressure unequal.
Mower (Or Other Attachment) Stops When Vehicle Is Operated in REVERSE	Normal condition. (See Using Reverse Implement Option in the OPERATING section.)

STORAGE

Storing Safety



CAUTION: Avoid injury! Fuel vapors are explosive and flammable. Engine exhaust fumes contain carbon monoxide and can cause serious illness or death:

- Run the engine only long enough to move the machine to or from storage.
- Do not store vehicle with fuel in the tank inside a building where fumes may reach an open flame or spark.
- Allow the engine to cool before storing the machine in any enclosure.

Preparing Machine for Storage

1. Repair any worn or damaged parts. Replace parts if necessary. Tighten loose hardware.
2. Repair scratched or chipped metal surfaces to prevent rust.
3. Remove grass and debris from machine.
4. Clean under the deck and remove grass and debris from inside chute and bagger.
5. Wash the machine and apply wax to metal and plastic surfaces.
6. Run machine for five minutes to dry belts and pulleys.
7. Apply light coat of engine oil to pivot and wear points to prevent rust.
8. Lubricate grease points.
9. Check tire pressure.

Preparing Fuel and Engine For Storage

Fuel:

If you have been using "Stabilized Fuel," add stabilized fuel to tank until the tank is full.

NOTE: Filling the fuel tank reduces the amount of air in the fuel tank and helps reduce deterioration of fuel.

If you are not using "Stabilized Fuel:"

1. Park machine safely in a well-ventilated area. (See Parking Safely in the SAFETY section.)

NOTE: Try to anticipate the last time the machine will be used for the season so very little fuel is left in the fuel tank.

2. Turn on engine and allow to run until it runs out of fuel.
3. Turn key to OFF position.

IMPORTANT: Avoid damage! Stale fuel can produce varnish and plug carburetor or injector components and affect engine performance.

- Add fuel conditioner or stabilizer to fresh fuel before filling tank.

4. Mix fresh fuel and fuel stabilizer in separate container. Follow stabilizer instructions for mixing.
5. Fill fuel tank with stabilized fuel.
6. Run engine for a few minutes to allow fuel mixture to circulate through carburetor on gas engine or fuel injectors on diesel engine.

Engine:

Engine storage procedure should be used when vehicle is not to be used for longer than 60 days.

1. Change engine oil and filter while engine is warm.
 2. Service air filter if necessary.
 3. Clean debris from engine air intake screen.
 4. On gas engines:
 - Remove spark plugs. Put 30 mL (1 oz.) of clean engine oil in cylinders.
 - Install spark plugs, but do not connect spark plug wires.
 - Crank the engine five or six times to allow oil to be distributed.
 5. Clean the engine and engine compartment.
 6. Remove battery.
 7. Clean the battery and battery posts. Check the electrolyte level, if your battery is not maintenance free.
 8. Close fuel shut-off valve, if your machine is equipped.
 9. Store the battery in a cool, dry place where it will not freeze.
- NOTE: The stored battery should be recharged every 90 days.**
10. Charge the battery.

IMPORTANT: Avoid damage! Prolonged exposure to sunlight could damage the hood surface. Store machine inside or use a cover if stored outside.

11. Store the vehicle in a dry, protected place. If vehicle is

STORAGE

stored outside, put a waterproof cover over it.

Removing Machine From Storage

1. Check tire pressure.
2. Check engine oil level.
3. Check battery electrolyte level, if your battery is not maintenance free. Charge battery if necessary.
4. Install battery.
5. On gas engines: Check spark plug gap. Install and tighten plugs to specified torque.
6. Lubricate all grease points.
7. Open fuel shut-off valve, if your machine is equipped.
8. Run the engine 5 minutes without the mower or any attachments running to allow oil to be distributed throughout engine.
9. Be sure all shields and guards or deflectors are in place.

ASSEMBLY

Charge and Connect Battery



CAUTION: Avoid injury! The battery produces a flammable and explosive gas. The battery may explode:

- Do not smoke near battery.
- Wear eye protection and gloves.
- Do not allow direct metal contact across battery posts.
- Remove negative cable first when disconnecting.
- Install negative cable last when connecting.

1. Remove and discard the red positive (+) protective cap from the positive (+) battery terminal.
2. Charge the battery.
 - Battery is fully charged at 12.6 volts.

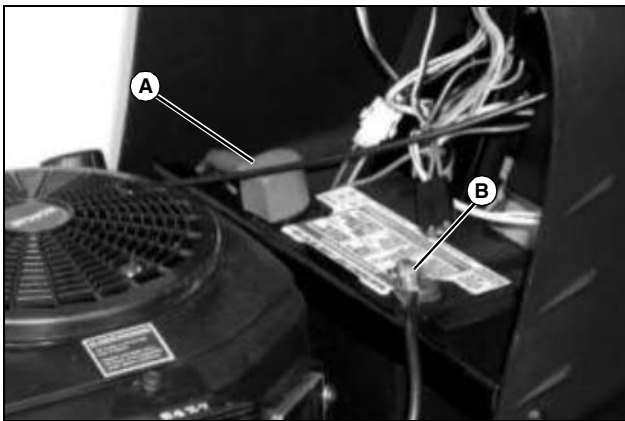

MX17056



MX7686

3. Connect positive (+) battery cable (A) to battery.
4. Connect negative (-) battery cable (B).
5. Apply general purpose grease or silicone spray to terminal to help prevent corrosion.

6. Slide red cover over positive battery cable.

Check Tire Pressure



CAUTION: Avoid injury! Explosive separation of tire and rim parts is possible when they are serviced incorrectly:

- Do not attempt to mount a tire without the proper equipment and experience to perform the job.
- Do not inflate the tires above the recommended pressure.
- Do not weld or heat a wheel and tire assembly. Heat can cause an increase in air pressure resulting in an explosion. Welding can structurally weaken or deform the wheel.
- Do not stand in front or over the tire assembly when inflating. Use a clip-on chuck and extension hose long enough to allow you to stand to one side.

1. Check tires for damage.
2. Check tire pressure with an accurate gauge.
3. Check that tires have equal air pressure. Add or remove air, if necessary.

Tire Size	Pressure
Front:	
Models L100, 110 and L118	
• 15 x 6.00 - 6	97 kPa (14 psi)
Models L120 and L130	
• 16 x 6.5 - 8	83 kPa (12 psi)
Rear:	
Models L100 and L110	
• 20 x 8.0 - 8	69 kPa (10 psi)
Model L118	
• 20 x 10.0 - 8	69 kPa (10 psi)
Models L120 and L130	
• 22 x 9.5 - 12	69 kPa (10 psi)

Adjust Mower Level

Adjust mower level. (See Adjusting Mower Level in the OPERATING section.)

ASSEMBLY

Check Engine Oil Level

Check engine oil level. (See Checking Engine Oil Level in the SERVICE ENGINE section.)

Check Machine Safety System

Perform safety system check to make sure the electronic safety interlock circuit is functioning properly. Perform all tests. (See Testing Safety System in the OPERATING section.)

Break-In Electric PTO Clutch (If Equipped)

1. Start engine and move machine to flat level surface.



MX10501

2. Push throttle lever (A) up to full throttle position.
3. Engage PTO (B) and allow mower to run for 10 seconds.
4. Disengage PTO and wait 10 seconds.
5. Repeat steps 2 and 3 for 12-15 cycles.

NOTE: PTO clutch is now properly burnished.

SPECIFICATIONS

Gear Model L100

Engine Manufacturer	Briggs & Stratton 51
Horsepower	12.7 kW (17 hp)
Displacement	508 cc (31 cu.in.)
Spark Plug-Gap	0.76 mm (0.030 in.)
Cylinders	One
Oil Filter	None
Air Filter	Paper with Foam
Transmission	Gear Transaxle
Transaxle Manufacturer	Dana 4360
Travel Speeds	5

Gear Speed Range

1st	2.4 km/h (1.5 mph)
2nd	3.2 km/h (2.0 mph)
3rd	5.0 km/h (3.1 mph)
4th	6.4 km/h (4.0 mph)
5th	8.0 km/h (5.0 mph)
Reverse	3.7 km/h (2.3 mph)

Automatic Model L110

Engine Manufacturer	Kohler CV491
Horsepower	13 kW (17.5 hp)
Displacement	490 cc (29.9 cu.in.)
Spark Plug-Gap	0.76 mm (0.030 in.)
Cylinders	One
Oil Filter	Yes
Air Filter	Paper with Foam
Transmission	Hydrostatic
Transaxle Manufacturer	Tuff Torq™ K46
Travel Speed - Forward	0 - 9.2 km/h (0 - 5.7 mph)
Travel Speed - Reverse	0 - 5.5 km/h (0 - 3.4 mph)

Automatic Model L118

Engine Manufacturer	Briggs & Stratton CV40
Horsepower	14.9 kW (20 hp)
Displacement	656 cc (40.0 cu.in.)
Spark Plug-Gap	0.76 mm (0.030 in.)
Cylinders	Two

SPECIFICATIONS

Oil Filter	Yes
Air Filter	Paper with Foam
Transmission	Hydrostatic
Transaxle Manufacturer	Tuff Torq™ K46V
Travel Speed - Forward	0 - 9.2 km/h (0 - 5.7 mph)
Travel Speed - Reverse	0 - 5.5 km/hr (0 - 3.4 mph)

Automatic Model L120

Engine Manufacturer	Briggs & Stratton CV40
Horsepower	14.9 kW (20 hp)
Displacement	656 cc (40.0 cu.in.)
Spark Plug-Gap	1mm (0.040 in.)
Cylinders	Two
Oil Filter	Yes
Air Filter	Dry, Replaceable Foam
Transmission	Hydrostatic
Transaxle Manufacturer	Tuff Torq™ HD K46
Travel Speed - Forward	0 - 8.4 km/h (0 - 5.2 mph)
Travel Speed - Reverse	0 - 4.7 km/h (0 - 2.9 mph)

Automatic Model L130

Engine Manufacturer	Kohler CV23S
Horsepower	17.2 kW (23 hp)
Displacement	674 cc (41.1 cu in.)
Spark Plug-Gap	0.76 mm (0.030 in.)
Spark Plug-Torque	24.4-29.8 N•m (18-22 lb-ft)
Cylinders	Two
Stroke/Cycle	Four
Lubrication	Full-Pressure
Oil Filter	Yes
Air Cleaner	Dual Stage
Transmission	Hydrostatic
Transaxle Manufacturer	Tuff Torq™ HD K46
Travel Speed - Forward	0 - 8.4 km/h (0 - 5.2 mph)
Travel Speed - Reverse	0 - 4.7 km/h (0 - 2.9 mph)

SPECIFICATIONS

Electrical System (All Models)

Charging System	Regulated Circuit
Charging System Capacity (L100, L110)	9 Amp
Charging System Capacity (L118, 120, L130)	16 Amp
Battery Voltage	12 Volts
Battery Type	BCI Group U1

Capacities

Model L100

Crankcase without oil filter	1.4 L (1.5 qt)
Fuel	7.9 L (2.1 gal)

Model L110, L118, L120 and L130

Crankcase without oil filter	1.8 L (1.9 qt)
Crankcase with oil filter	1.9 L (2 qt)
Fuel	7.9 L (2.1 gal)

Dimensions (All Models)

Height	98 cm (38.6 in.)
Length (Overall)	152.4 cm (60 in.)
Width (Overall)	91 cm (36 in.)
Weight: L100 and L110	210 kg (462 lb)
Weight: L118	235 kg (520 lb)
Weight: L120 and L130	241 kg (532 lb)

Tires

Models L100 and L110

Size (Front)	15 x 6.00 - 6
Size (Rear)	20 x 8.0 - 8
Tire Pressure (Front)	97 kPa (14 psi)
Tire Pressure (Rear)	69 kPa (10 psi)

Model L118

Size (Front)	15 x 6.00 - 6
Size (Rear)	20 x 10.00 - 8
Tire Pressure (Front)	97 kPa (14 psi)
Tire Pressure (Rear)	69 kPa (10 psi)

SPECIFICATIONS

Models L120 and L130

Size (Front)	16 x 6.5 - 8
Size (Rear)	22 x 9.5 - 12
Tire Pressure (Front)	83 kPa (12 psi)
Tire Pressure (Rear)	69 kPa (10 psi)

Mower Deck - 107 cm (42 in.)

Blades-Rotary	2
Blade Bolt Torque	62 N•m (46 lb-ft)
Cutting Height-Approx.	25–102 mm (1–4 in.)
Cutting Width	1067 mm (42 in.)

Mower Deck - 122 cm (48 in.)

Blades-Rotary	3
Blade Bolt Torque	62 N•m (46 lb-ft)
Cutting Height-Approx.	25–102 mm (1–4 in.)
Cutting Width	1219 mm (48 in.)

Recommended Lubricants

Engine Oil	API Service Classification SG or SF
Grease	SAE Multi-Purpose EP Grease
Lubricant	General All-Purpose Spray

(Specifications and design subject to change without notice.)

WARRANTY

Product Warranty

Product warranty is provided as part of John Deere's support program for customers who operate and maintain their equipment as described in this manual.

Engine related warranties stated in this manual refer only to emissions-related parts and components of your engine. The complete engine warranty, less emission-related parts and components, is provided separately as the "Limited Warranty for New John Deere Commercial & Consumer Equipment".

John Deere, Federal and California Emission Control System Warranty (Small Off-Road Gas Engines)

Your Warranty Rights and Obligations

The United States Environmental Protection Agency (EPA), the California Air Resources Board (CARB) and John Deere are pleased to explain the emission control system warranty on your 1995 or later small off-road equipment engine. In California, 1995 and later small off-road equipment engines must be designed, built and equipped to meet the State's stringent anti-smog standards. In other states, 1997 and later model year equipment engines must be designed, built and equipped to meet the U.S. EPA regulations for small non-road, spark ignition engines. John Deere must warrant the emission control system on your small off-road equipment engine for the periods of time listed below provided there has been no abuse, neglect or improper maintenance of your small off-road equipment engine.

Your emission control system may include parts such as the carburetor, fuel-injection system and ignition system. Also included may be connectors and other emission related assemblies.

Where a warrantable condition exists, John Deere will repair your small off-road equipment engine at no cost to you including diagnosis, parts and labor.

John Deere Emission Control System Warranty Coverage

In California, 1995 and later small off-road equipment engines are warranted relative to emission control parts for two years. In other states, 1997 and later model year equipment engines are warranted relative to emission control parts for two years. If any emission related part on your engine is defective, the part will be repaired or replaced by John Deere.

Owner's Warranty Responsibilities

As the small off-road equipment engine owner, you are responsible for the performance of the required maintenance listed in your owner's manual. John Deere recommends that you retain all receipts covering maintenance on your small off-road equipment engine, but John Deere cannot deny warranty solely for lack of receipts or for your failure to ensure the performance of all scheduled maintenance.

As the small off-road equipment engine owner, you should however be aware that John Deere may deny you warranty coverage if your small off-road equipment engine or a part has failed due to abuse, neglect, improper maintenance or unapproved modifications.

You are responsible for presenting your small off-road equipment engine to an authorized John Deere Commercial and Consumer Equipment Retailer as soon as a problem exists. The warranty repairs should be completed in a reasonable amount of time, not to exceed 30 days.

If you have any questions regarding your warranty rights and responsibilities, you should contact your John Deere Commercial and Consumer Equipment Retailer, or the John Deere Customer Communications Center at 1-800-537-8233.

Length Of Warranty Coverage

John Deere warrants to the initial owner and each subsequent purchaser that the small off-road equipment engine is:

- Designed, built and equipped so as to conform with all applicable regulations adopted by the California Air Resources Board (CARB) for 1995 and later equipment engines, and all applicable regulations of the United States Environmental Protection Agency (EPA) for 1997 and later equipment engines; and
- Free from defects in materials and workmanship which can cause the failure of an emission warranted part for a period of two years after the engine is delivered to the initial retail purchaser. John Deere is liable for damages to other engine components caused by the failure of a warranted part during the warranty period. If any emission related part on your engine is defective, the part will be repaired or replaced by John Deere.

Warranted Parts

Coverage under this warranty extends only to the parts listed below (the emission control system parts) to the extent these parts were present on the engine purchased.

Fuel Metering System:

- Carburetor and internal parts (or fuel injection system).
- Air/fuel ratio feedback and control system.
- Cold start enrichment system.

Air Induction System:

- Air Cleaner
- Intake manifold.

Ignition System:

- Spark plugs.
- Magneto or electronic ignition system.
- Spark advance/retard system.

Catalyst System:

- Exhaust manifold.

Miscellaneous Items Used in Above Systems

- Vacuum and temperature switches.
- Electronic controls.
- Hoses, belts, connectors and assemblies.

Since emission related parts may vary slightly from model to model, certain models may not contain all of these parts and certain models may contain functionally equivalent parts.

Warranty Service And Charges

Warranty service shall be provided during customary business hours at any authorized John Deere Commercial and Consumer Equipment Retailer. Repair or replacement of any warranted part will be performed at no charge to the owner, including diagnostic labor which leads to the determination that a warranted part is defective, if the diagnostic work is performed at an authorized John Deere Commercial and Consumer Equipment Retailer. Any parts replaced under this warranty shall become the property of John Deere.

Maintenance Warranty Coverage

a) Any warranted part that is not scheduled for replacement as required maintenance must be warranted as to defects for the warranty period. Any such part repaired or replaced under the warranty must be warranted for the remaining warranty period.

b) Any warranted part that is scheduled only for regular inspection to the effect of "repair or replace as necessary" must be warranted as to defects

WARRANTY

for the warranty period. Any such part repaired or replaced under the warranty must be warranted for the remaining warranty period.

c) Any warranted part which is scheduled for replacement as required maintenance must be warranted as to defects only for the period of time up to the first scheduled replacement for that part. Any such part repaired or replaced under the warranty must be warranted for the remainder of the period prior to the first scheduled replacement point for that part.

d) Normal maintenance, replacement or repair of emission control devices and systems, which are being done at the customers expense, may be performed by any repair establishment or individual; however, warranty repairs must be performed by an authorized John Deere Commercial and Consumer Equipment Retailer.

e) Any replacement part that is equivalent in performance and durability may be used in the performance of any non-warranty maintenance or repairs, and shall not reduce the warranty obligations of John Deere.

Consequential Warranty Coverage

Warranty coverage shall extend to the failure of any engine components caused by the failure of any warranted part still under warranty.

Limitations

This Emission Control System Warranty shall NOT cover any of the following:

- a) Repair or replacement required as a result of (i) misuse or neglect, (ii) improper maintenance or unapproved modifications, (iii) repairs improperly performed or replacements improperly installed, (iv) use of replacement parts or accessories not conforming to John Deere specifications which adversely affect performance and/or durability, (v) alterations or modifications not recommended or approved in writing by John Deere.
- b) Replacement parts, other services and adjustments necessary for normal maintenance.
- c) Transportation to and from the John Deere Commercial and Consumer Equipment Retailer, or service calls made by the Retailer.

Limited Liability

a) The liability of John Deere under this Emission Control System Warranty is limited solely to the remedying of defects in materials or workmanship. This warranty does not cover inconvenience or loss of use of the small off-road equipment engine or transportation of the engine to or from the John Deere Commercial And Consumer Equipment Retailer. JOHN DEERE SHALL NOT BE LIABLE FOR ANY OTHER EXPENSE, LOSS, OR DAMAGE, WHETHER DIRECT, INCIDENTAL, CONSEQUENTIAL (EXCEPT AS LISTED ABOVE UNDER "COVERAGE") OR EXEMPLARY ARISING IN CONNECTION WITH THE SALE OR USE OF OR INABILITY TO USE THE SMALL OFF-ROAD EQUIPMENT ENGINE FOR ANY OTHER PURPOSE.

b) NO EXPRESS EMISSION CONTROL SYSTEM WARRANTY IS GIVEN BY JOHN DEERE WITH RESPECT TO THE ENGINE EXCEPT AS SPECIFICALLY SET FORTH IN THIS DOCUMENT. ANY EMISSION CONTROL SYSTEM WARRANTY IMPLIED BY LAW, INCLUDING ANY WARRANTY OF MERCHANTABILITY OR FITNESS FOR A PARTICULAR PURPOSE, IS EXPRESSLY LIMITED TO THE EMISSION CONTROL SYSTEM WARRANTY TERMS SET FORTH IN THIS DOCUMENT.

c) No dealer is authorized to modify this Federal, California and John Deere Emission Control System Warranty.

Tire Warranty

John Deere warranty applies for tires available through the John Deere parts system. For tires not available through the John Deere parts system, the tire manufacturer's warranty applicable to your machine may not apply outside the U.S. (See your John Deere dealer for specific information.)

Limited Battery Warranty

NOTE: Applicable in North America only. For complete machine warranty, reference a copy of the John Deere warranty statement. Contact your John Deere dealer to obtain a copy.

TO SECURE WARRANTY SERVICE

The purchaser must request warranty service from a John Deere dealer authorized to sell John Deere batteries, and present the battery to the dealer with the top cover plate codes intact.

FREE REPLACEMENT

Any new battery which becomes unserviceable (not merely discharged) due to defects in material or workmanship within 90 days of purchase will be replaced free of charge. Installation costs will be covered by warranty if (1) the unserviceable battery was installed by a John Deere factory or dealer, (2) failure occurs within 90 days of purchase, and (3) the replacement battery is installed by a John Deere dealer.

PRO RATA ADJUSTMENT

Any new battery which becomes unserviceable (not merely discharged) due to defects in material or workmanship more than 90 days after purchase, but before the expiration of the applicable adjustment period, will be replaced upon payment of the battery's current list price less a pro rata credit for unused months of service. The applicable adjustment period is determined from the Warranty Code printed at the top of the battery and chart below. Installation costs are not covered by warranty after 90 days from the date of purchase.

THIS WARRANTY DOES NOT COVER

- A. Breakage of the container, cover, or terminals.
- B. Depreciation or damage caused by lack of reasonable and necessary maintenance or by improper maintenance.
- C. Transportation, mailing, or service call charges for warranty service.

LIMITATION OF IMPLIED WARRANTIES AND PURCHASER'S REMEDIES

To the extent permitted by law, neither John Deere nor any company affiliated with it makes any warranties, representations, or promises as to the quality, performance or freedom from defect of the products covered by this warranty. IMPLIED WARRANTIES OF MERCHANTABILITY AND FITNESS FOR A PARTICULAR PURPOSE, TO THE EXTENT APPLICABLE, SHALL BE LIMITED IN DURATION TO THE APPLICABLE ADJUSTMENT PERIOD SET FORTH HERE. THE PURCHASER'S ONLY REMEDIES IN CONNECTION WITH THE BREACH OR PERFORMANCE OF ANY WARRANTY ON JOHN DEERE BATTERIES ARE THOSE SET FORTH HERE. IN NO EVENT WILL THE DEALER, JOHN DEERE OR ANY COMPANY AFFILIATED WITH JOHN DEERE BE LIABLE FOR INCIDENTAL OR CONSEQUENTIAL DAMAGES. (Note: Some states do not allow limitations on how long an implied warranty lasts or the exclusion or limitation of incidental or consequential damages. So these limitations and exclusions may not apply to you.) This warranty gives you specific legal rights, and you may also have some rights which vary from state to state.

WARRANTY

NO DEALER WARRANTY

The selling dealer makes no warranty of its own and the dealer has no authority to make any representation or promise on behalf of John Deere, or to modify the terms or limitations of this warranty in any way.

PRO RATA MONTHS OF ADJUSTMENT

NOTE: If your battery is not labeled with a warranty code, it is a warranty code "B".

Warranty Code	Warranty Period
A	40 Months
B	36 Months
C	24 Months

INDEX

A

Accessories, Miscellaneous	12
Air Cleaner Elements (17 hp Briggs and Stratton), Checking and Cleaning	34
Air Cleaner Elements (17.5hp Kohler Engine), Checking and Cleaning	35
Air Cleaner Elements (20hp Briggs and Stratton), Checking and Cleaning	36
Air Cleaner Elements (23hp Kohler) Checking and Cleaning	37
Axle Pivot, Lubricating Front	32

B

Balancing Blades	47
Battery and Terminals, Cleaning	48
Battery, Charge and Connect at Assembly	59
Battery, Removing and Installing	48
Battery, Using Booster	49
Belt Tension (107 cm (42 in.) Deck), Adjusting	45
Belt, (107 cm (42 in.) Deck), Replacing Mower Drive	44
Belt, 122 cm (48 in.), Replacing Mower Drive	44
Belt, Installing and Removing Mower Drive Belt at Engine Drive Sheave (122 cm (48 in.) only)	41
Blades, Balancing	47
Blades, Checking Mower	46
Blades, Servicing Mower	46
Blades, Sharpening	47
Brake (107 cm (42 in.) Deck), Adjusting Spindle	45
Brake Switch, Testing Park	16
Brake, Testing Park	16
Brake, Using Park	18
Bulb, Replacing Headlight	49
Bushings and Spindles, Lubricating Front Wheel	32

C

Capacities Specifications	63
Carburetor, Adjusting	39
CargO Mount System, Using	27
Certification Label	3
Chains, Using Tire	28
Cleaning Air Intake Screen	34
Controls on Automatic Transmission, Using Travel	22
Controls on Gear Transmission, Using Travel	21
Controls, Miscellaneous	11
Controls, Operator Station	10
Cruise Control, Using	23
Cutting Height, Adjusting	13

D

Daily Operating Checklist	10
Dimensions Specifications	63

E

Electrical Specifications	63
---------------------------------	----

Electrical Troubleshooting	55
Emission Compliance Period	3
Emission Control System Certification Label	2
Engine Idling	20
Engine Oil	33
Engine Oil Level, Check	59
Engine Oil Level, Checking	33
Engine Oil and Filter, Changing	34
Engine Specifications	61
Engine Troubleshooting	53
Engine Warranty Maintenance Statement	33
Engine and Fuel Storage, Preparing	57
Engine, Starting	19
Engine, Stopping	20

F

Filter, Changing Engine Oil	34
Filter, Replacing Fuel	39
Free-Wheeling Lever, Using	25
Fuel Filter, Replacing	39
Fuel Gauge, Using	19
Fuel Safety	8
Fuel Storage	57
Fuel Tank, Filling	50
Fuel, Using Proper	50
Fuse, Replacing	49

G

Gear Transmission, Using Travel Controls on	21
Grease	32

H

Headlight Bulb, Replacing	49
Headlights, Using	21
Height, Adjusting Cutting	13
Hood, Removing and Installing	50
Hour Meter, Using Service Reminder	19

I

Idling Engine	20
Installing Mower Deck	42
Intervals for Service	30

L

Label, Certification	3
Labels, Safety	1
Level (Side-to-Side) and (Front-to-Rear), Checking Mower 13	
Leveling Mower	14, 59
Lift Lever, Using Mower	24
Literature, Service	29
Lubricants Recommended Specifications	64
Lubricating Front Axle Pivot	32
Lubricating Front Wheel Bushings and Spindles	32
Lubricating Mower Deck Lift Linkage and Pivot Points	32

M

INDEX

Machine, Pushing	25	Sharpening Blades	47
Metal Surfaces, Repairing and Cleaning	51	Spark Arrestor, Using	4
Model L100 Specifications	61	Spark Plug, Checking	38
Model L110 Specifications	61	Spindle Brake (107 cm (42 in.) Deck), Adjusting	45
Model L118 Specifications	61	Spindles, Lubricating Front Axle Wheel Bushings and ...	32
Model L120 Specifications	62	Stopping Engine	20
Model L130 Specifications	62	Storage Compartments, Using	27
Mower Blades, Checking	46	Storage, Preparing Fuel and Engine for	57
Mower Blades, Servicing	46	Storage, Preparing Machine for	57
Mower Deck 107 cm (42 in.), Specifications	64	Storage, Removing Machine from	58
Mower Deck 122 cm (48 in.), Specifications	64	Storing Safety	57
Mower Deck Lift Linkage Lubrication	32	T	
Mower Deck Wheels, Adjusting	15	Technical Manual	29
Mower Deck, Installing	42	Testing Safety Systems	16
Mower Deck, Removing	41	Tire Chains, Using	28
Mower Drive Belt, 107 cm (42 in.), Replacing	44	Tire Pressure at Assembly, Check	59
Mower Drive Belt, 122 cm (48 in.), Replacing	44	Tire Specifications	63
Mower Level (Side-to-Side) and (Front-to-Rear) Check .	13	Tractor Troubleshooting	55
Mower Level, Adjusting	14, 59	Transmission, Checking (See your John Deere dealer) .	40
Mower Lift Lever, Using	24	Transporting Machine on Trailer	25
Mower Troubleshooting	55	Travel Controls on Automatic Transmission, Using	22
Mower, Using (Engaging and Disengaging)	24	Troubleshooting Chart	53
Mowing Tips	28	W	
Mulch Cover, Using	26	Warranty Maintenance Statement, Engine	33
O		Warranty Registration, Refer to the Production Identification Section	-1
OMGX21647K3	-3	Warranty, Product	65
Oil Level, Check Engine	59	Weights, Using	27
Oil Level, Checking Engine	33	Wheel Bushings and Spindle Lubrication	32
Oil and Filter, Changing Engine	34	Wheels, Adjusting Mower Deck	15
Oil, Engine	33		
Operating Checklist, Daily	10		
P			
PTO Switch, Testing	17		
Park Brake, Using	18		
Parts Catalog	29		
Parts, Replacement	29		
Plastic And Painted Surfaces, Avoid Damage To	10		
Plastic Surface Cleaning and Repairing Surfaces	51		
Power Port (Models with 20 hp or More), Using	27		
R			
Removing Mower Deck	41		
Reverse Implement Option, Testing	18		
Reverse Implement Option, Using the	23		
S			
Safety Messages	3		
Safety Systems, Testing	16		
Safety, Tire	8		
Safety-Alert Symbol	1		
Seat Switch, Testing	17		
Seat, Adjusting	12		
Service Intervals	30		
Service Literature	29		
Service Reminder, Using	19		

NOTES
