

FOREWORD

This manual covers the service procedures of the TOYOTA ELECTRIC POWERED FORKLIFT 7FBE10 to 20 series.

Please use these manuals for providing quick, correct servicing of the corresponding forklift models.

This manual deals with the above models as of February 2003. Please understand that disagreement can take place between the descriptions in the manual and actual vehicles due to change in design and specifications. Any change or modifications thereafter will be informed by Toyota Industrial Equipment Parts & Service News.

TOYOTA Material Handling Company

A Division of TOYOTA INDUSTRIES CORPORATION

SECTION INDEX

NAME	SECTION
GENERAL	0
BATTERY	1
CHARGER (OPT)	2
CONTROLLER	3
MULTI-DISPLAY FUNCTIONS	4
TROUBLESHOOTING	5
MOTOR	6
DRIVE UNIT & FRONT AXLE	7
REAR AXLE	8
STEERING	9
BRAKE	10
BODY & FRAME	11
MATERIAL HANDLING SYSTEM	12
MAST	13
CYLINDER	14
OIL PUMP	15
OIL CONTROL VALVE	16
SAS FUNCTIONS (OPT)	17
APPENDIX	18

GENERAL

	Page		Page
VEHICLE EXTERIOR VIEW.....	0-2	HIGH PRESSURE HOSE FITTING	
VEHICLE MODELS.....	0-3	TIGHTENING TORQUE.....	0-17
FRAME NUMBER.....	0-3	RECOMMENDED LUBRICANT	
HOW TO USE THIS MANUAL	0-4	QUANTITY AND TYPES	0-18
EXPLANATION METHOD	0-4	LUBRICATION CHART.....	0-19
TERMINOLOGY.....	0-5	PERIODIC MAINTENANCE.....	0-20
ABBREVIATIONS.....	0-5	PERIODIC REPLACEMENT OF	
SI UNITS	0-6	PARTS AND LUBRICANTS	0-25
OPERATING TIPS	0-7		
GENERAL INSTRUCTIONS.....	0-7		
JACK-UP POINT	0-8		
HOISTING THE VEHICLE	0-9		
WIRE ROPE SUSPENSION ANGLE			
LIST	0-10		
SAFE LOAD FOR EACH WIRE ROPE			
SUSPENSION ANGLE	0-10		
MEMBER WEIGHTS.....	0-11		
TOWING THE VEHICLE	0-11		
ELECTRICAL PARTS			
INSPECTION	0-12		
NOTES ON SAS	0-14		
STANDARD BOLT & NUT			
TIGHTENING TORQUE.....	0-15		
BOLT STRENGTH CLASS			
IDENTIFICATION METHOD	0-15		
TIGHTENING TORQUE TABLE	0-16		
PRECOATED BOLTS	0-17		

VEHICLE EXTERIOR VIEW

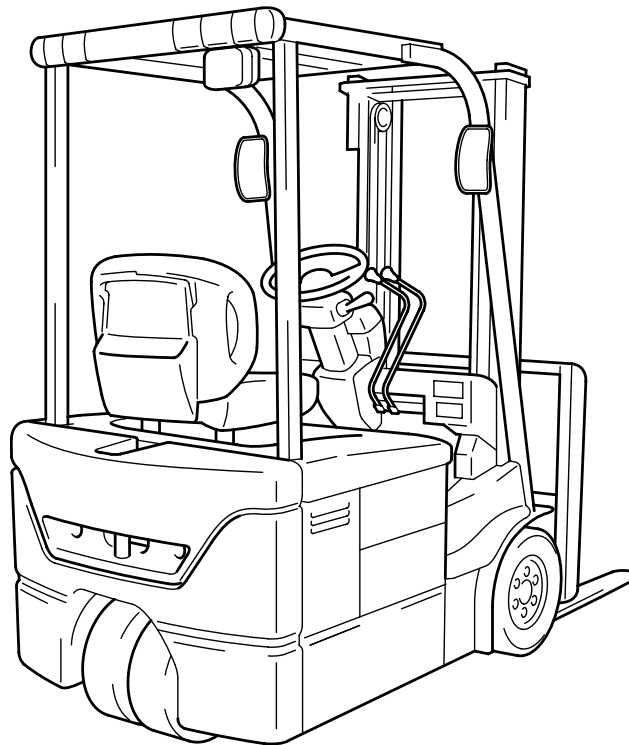
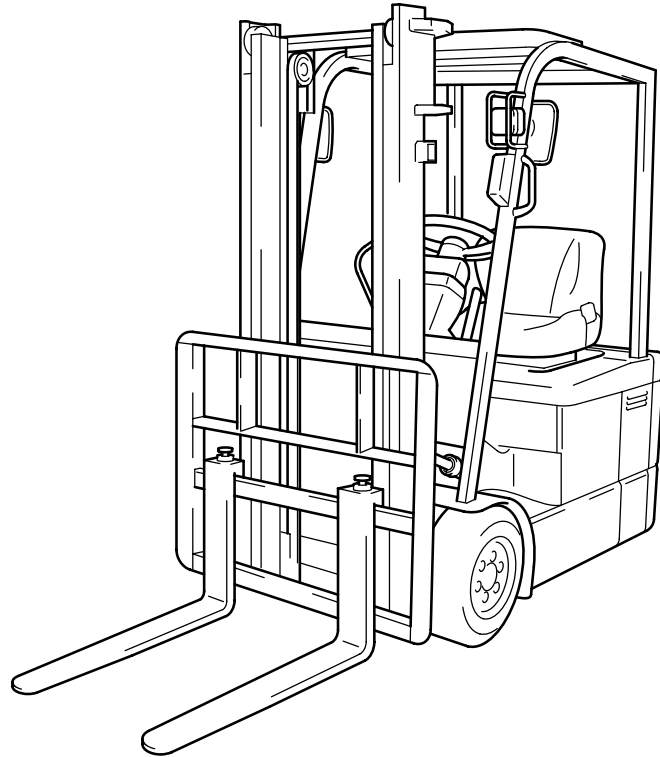

VEHICLE MODELS

Vehicle model code	Payload (ton)	Vehicle Model	Control method	Voltage (V)
10	1.0	7FBE10	AC microcomputer controller	48
13	1.25	7FBE13	↑	↑
15	1.5	7FBE15	↑	↑
18	1.75	7FBE18	↑	↑
20	2.0	7FBE20	↑	↑

0

FRAME NUMBER

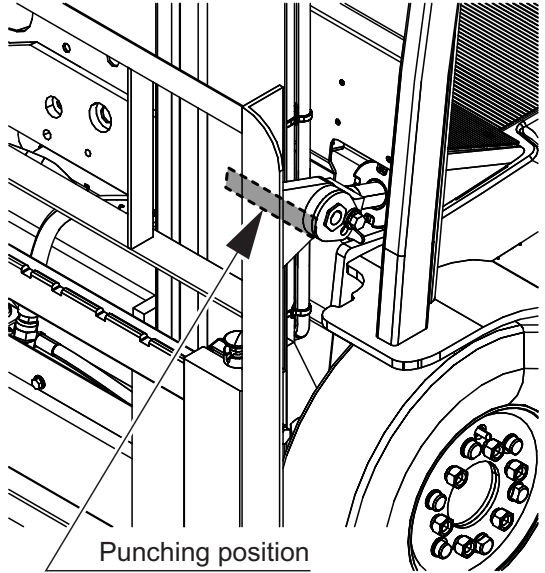
Vehicle model	Drive motor model	Punching format	Punching position
7FBE10	AR09	7FBE13-50011	 <p>Punching position</p>
7FBE13			
7FBE15		7FBE18-50011	
7FBE18			
7FBE20		7FBE20-50011	

HOW TO USE THIS MANUAL

EXPLANATION METHOD

1. Operating procedure

(1) Operating procedures are described using either pattern A or pattern B.

Pattern A: Each step of the operation is explained with its own illustration.

Pattern B: The entire operation is indicated by step numbers in one illustration, followed by cautions, notes, and point operations.

Example of pattern B

DISASSEMBLY · INSPECTION · REASSEMBLY

Tightening torque unit $T=N \cdot m(kg \cdot m)[ft \cdot lbf]$

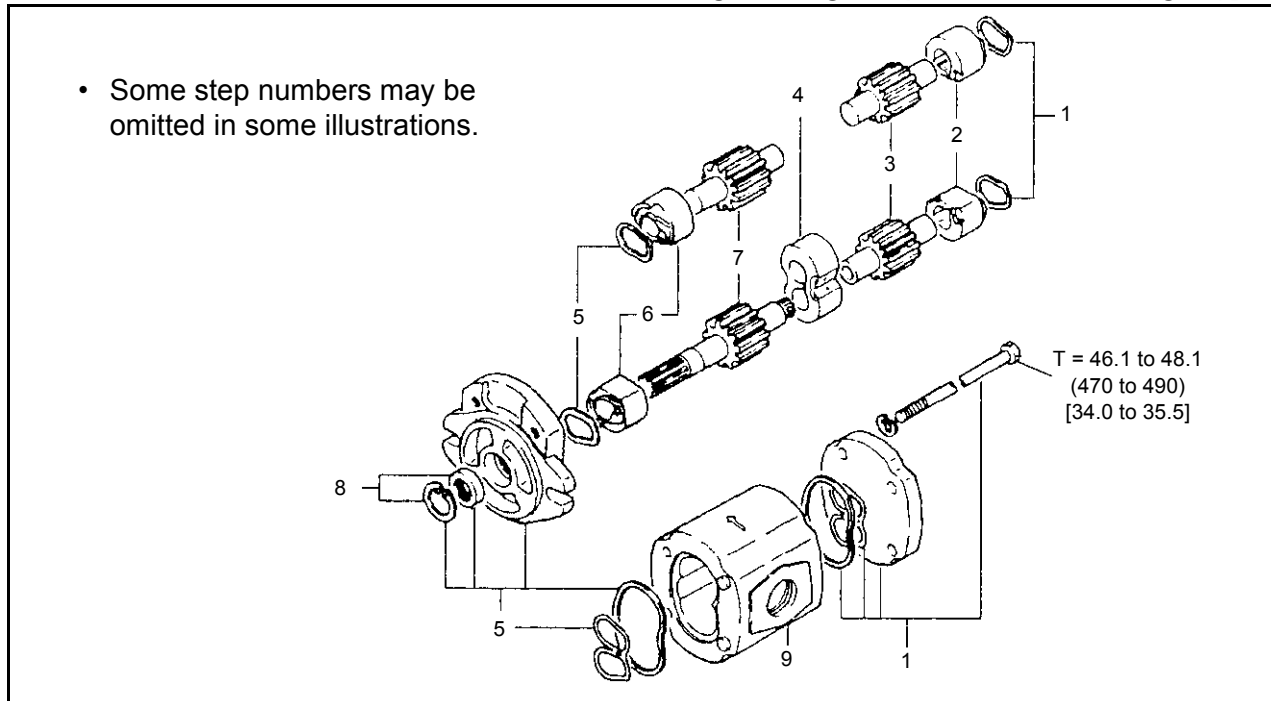

Disassembly Procedure

- 1 Remove the cover. [Point 1]
- 2 Remove the bushing. [Point 2]
- 3 Remove the gear.

← Operation to be explained

Point Operations

[POINT 1]

Disassembly:

Make match marks before removing the pump cover

Explanation of operation point with illustration

[POINT 2]

Inspection:

Measure the bushing inside diameter.

Limit 19.12 mm

1. How to read component figures

- (1) The component figures use the illustration in the parts catalog for the vehicle model. Please refer to the catalog to check the part name.

(Example)

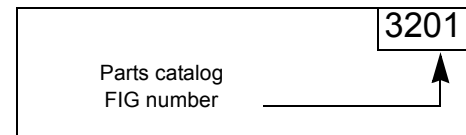

2. Matters omitted from this manual

- (1) This manual omits descriptions of the following jobs, but perform them in actual operation:
- Cleaning and washing of removed parts as required
 - Visual inspection (partially described)

0

TERMINOLOGY**CAUTION:**

Important matters, negligence of which may cause accidents. Be sure to observe them.

NOTE:

Important items, negligence of which may cause accidents, or matters in operating procedure which require special attention.

Standard: Value showing the allowable range in inspection or adjustment

Limit: The maximum or minimum value allowed in inspection or adjustment.

ABBREVIATIONS

Abbreviation	Meaning	Abbreviation	Meaning
ASSY	Assembly	SAE	Society of Automotive Engineers (USA)
ATT	Attachment	SAS	System of active stability
LH	Left Hand	SST	Special Service Tool
L/	Less	STD	Standard
OPT	Option	T=	Tightening Torque
O/S	Oversize	OOT	Number of teeth (OOT)
PS system	Power Steering	U/S	Undersize
RH	Right Hand	W/	With

SI UNITS

Meaning of SI

This manual uses SI units. SI represents the International System of Units, which was established to unify the various systems of units used in the past for smoother international technical communication.

New Units Adopted in SI

Item	New unit	Conventional unit	Conversion rate* ¹ (1 [conventional unit] = X [SI unit])
Force* ²	N (newton)	kgf	1 kgf = 9.80665 N
Torque* ² (Moment)	N·m	kgf·cm	1 kgf·cm = 9.80665 N·m
Pressure* ²	Pa (pascal)	kgf/cm ²	1 kgf/cm ² = 98.0665 kPa = 0.0980665 MPa
↑	↑	mmHg	1 mmHg = 0.133322 kPa
Revolving speed	rpm	rpm	1 rpm = 1 r/min
Spring con-	N/mm	kgf/mm	1 kgf/mm = 9.80665 N/mm
Volume	l	cc	1 cc = 1 ml
Power	W	PS system	1 PS = 0.735499 kW
Heat quantity	W·h	cal	1 kcal = 1.16279 W·h
Specific fuel	g/W·h	g/PS·h	1 g/PS·h = 1.3596 g/kW·h

<Reference>

* 1: X represents the value in SI units as converted from 1 [in conventional units], which can be used as the rate for conversion between conventional and SI units.

* 2: In the past, kilogram [kg] representing mass was often used in place of weight kilogram [kgf], which should be used as the unit of force.

Conversion between Conventional and SI Units

Equation for conversion

Value in SI unit = Conversion rate × Value in conventional unit	Conversion rate: Figure corresponding to X in the conversion rate column in the table above
Value in conventional unit = Value in SI unit ÷ Conversion rate	

When converting, change the unit of the value in conventional or SI units to the one in the conversion rate column in the table above before calculation. For example, when converting 100 W to the value in conventional unit PS, first change it to 0.1 kW and divide by the conversion rate 0.735499.

OPERATING TIPS

GENERAL INSTRUCTIONS

1. Skillful operation
 - (1) Prepare the tools, necessary measuring instruments (circuit tester, megohmmeter, oil pressure gauge, etc.) and SSTs before starting operation.
 - (2) Check the cable color and wiring state before disconnecting any wiring.
 - (3) When overhauling functional parts, complicated sections or related mechanisms, arrange the parts neatly to prevent confusion.
 - (4) When disassembling and inspecting a precision part such as the control valve, use clean tools and operate in a clean location.
 - (5) Follow the specified procedures for disassembly, inspection and reassembly.
 - (6) Always replace gaskets, packing, O-rings, self-locking nuts and cotter pins with new ones each time they are disassembled.
 - (7) Use genuine Toyota parts for replacement.
 - (8) Use specified bolts and nuts and observe the specified tightening torque when reassembling. (Tighten to the medium value of the specified tightening torque range.) If no tightening torque is specified, use the value given in the "standard tightening torque table".
2. Protection of functional parts (battery operated vehicles)
 - (1) Before connecting the battery plug after vehicle inspection or maintenance, thoroughly check each connector for any connection failure or imperfect connection.
Failure or imperfect connection of connectors related to controllers, especially, may damage elements inside the controllers.
3. Defect status check
Do not start disassembly and/or replacement immediately, but first check that disassembly and/or replacement is necessary for the defect.
4. Waste fluid disposal
Always use a proper container when draining waste fluid from the vehicle.
Careless discharge of oil, fuel, coolant, oil filter, battery or other harmful substance may adversely affect human health and the environment. Always collect and sort well, and ask specialized companies for appropriate disposal.

JACK-UP POINT

Always observe the following instructions when jacking up the vehicle:

- **When the fork is loaded, unload it and park the vehicle on a flat surface. Be sure to avoid an inclined or rough surface.**
- **Use a jack with ample capacity and jack up the vehicle at the specified jack-up point. Jacking up at any other point is dangerous.**
- **Always support the load of jacked-up vehicle with wooden blocks at specified points. Supporting the vehicle with the jack only is very dangerous.**
- **Never, under any circumstances, put any part of the body (including hands and feet) under the jacked-up vehicle.**

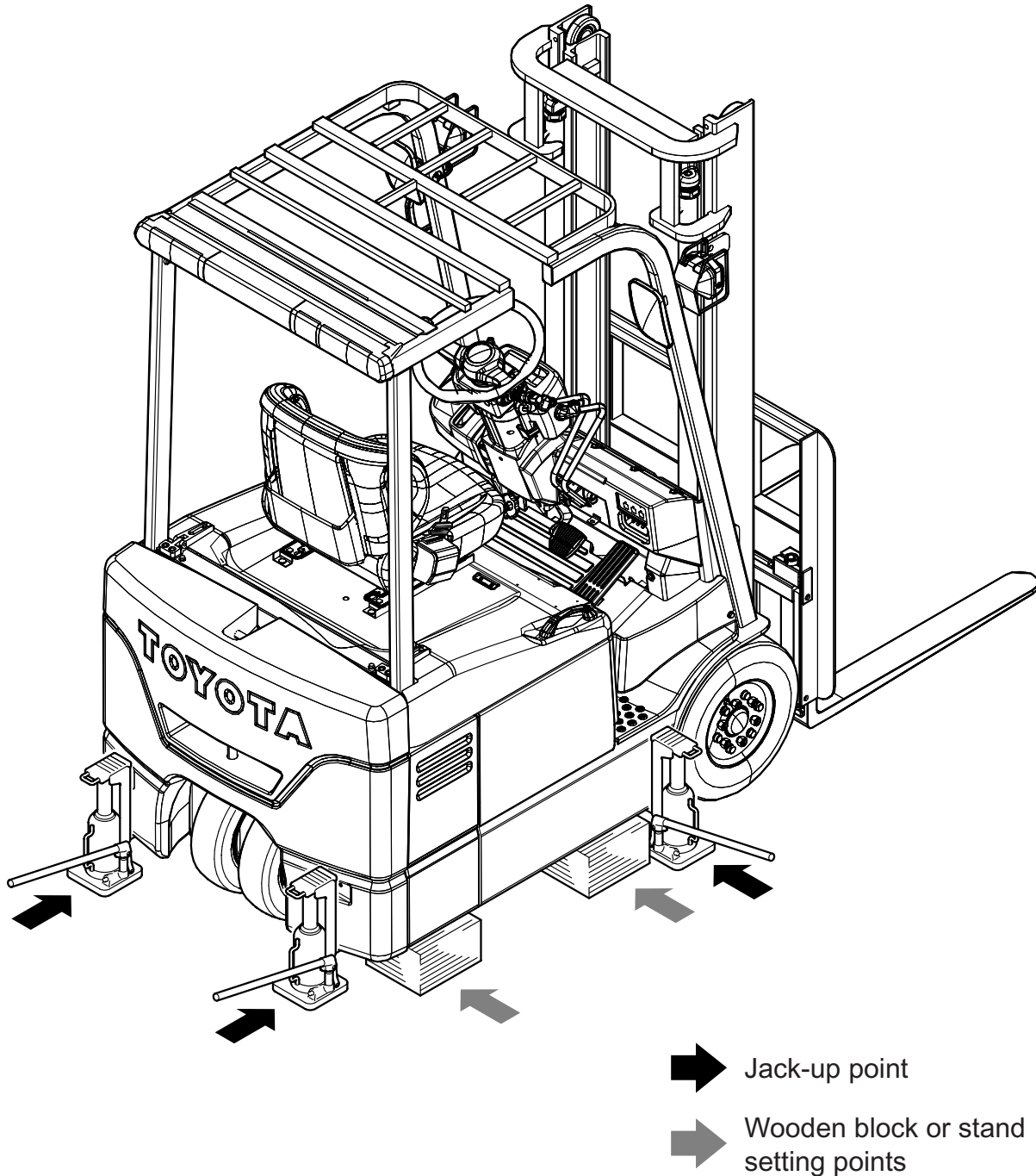

HOISTING THE VEHICLE

When hoisting the vehicle, always observe the specified hoist attachment section and method. Never hoist by any other attachment section as it is very dangerous.

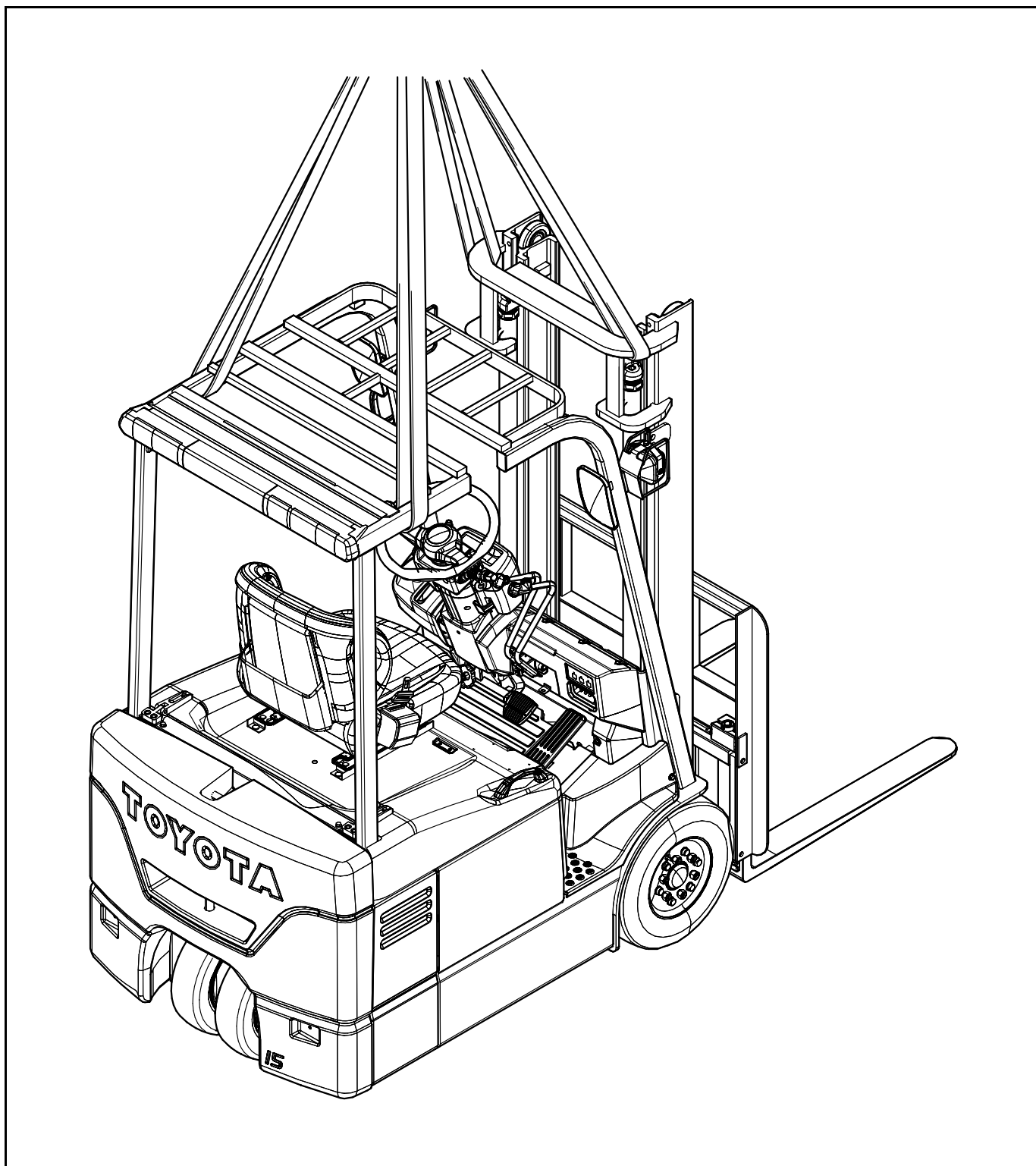

WIRE ROPE SUSPENSION ANGLE LIST

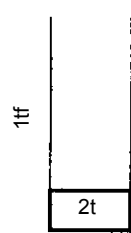
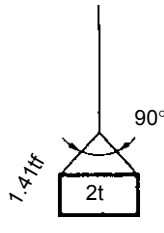
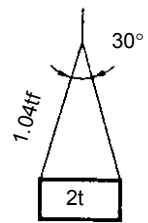
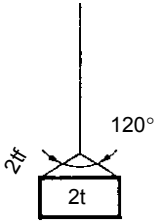
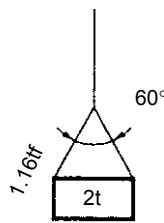
Suspension Angle	Tension	Compression	Suspension method	Suspension Angle	Tension	Compression	Suspension method
0°	1.00 time	0 time		90°	1.41 time	1.00 time	
30°	1.04 time	0.27 time		120°	2.00 time	1.73 time	
60°	1.16 time	0.58 time					

SAFE LOAD FOR EACH WIRE ROPE SUSPENSION ANGLE

Unit: N (tf) [lbf]

Rope diameter	Cutting load	Single-rope	Two-rope suspension					four-rope suspension			
		0°	0°	30°	60°	90°	0°	30°	60°	90°	
6 mm (0.24 in)	21380 (2.18) [4807]	3040 (0.31) [683.6]	6080 (0.62) [1367]	5880 (0.6) [1323]	5200 (0.53) [1169]	4310 (0.44) [970]	12160 (1.24) [2734]	11770 (1.2) [2646]	10400 (1.06) 2337	8630 (0.88) [1940]	
8 mm (0.32 in)	31480 (3.21) [7078]	4410 (0.45) [992.3]	8830 (0.9) [1985]	8530 (0.87) [1918]	7650 (0.78) [1720]	6280 (0.64) [1411]	17650 (1.8) [3969]	17060 (1.74) [3937]	15300 (1.56) [3440]	12550 (1.28) [2322]	
10 mm (0.4 in)	49230 (5.02) [11690]	6960 (0.71) [1565.6]	14020 (1.43) [3153]	13440 (1.37) [3021]	11770 (1.2) [2646]	9810 (1.0) [2205]	27460 (2.8) [6174]	26480 (2.7) [5954]	23540 (2.4) [5292]	19610 (2.0) [4410]	
12.5 mm (0.5 in)	76880 (7.84) [17387]	10980 (1.12) [2469.5]	21570 (2.2) [4851]	21280 (2.1) [4631]	18630 (1.9) [4190]	14710 (1.5) [3308]	43150 (4.4) [9702]	41190 (4.2) [9261]	37270 (3.8) [8379]	29420 (3.0) [6615]	
14 mm (0.56 in)	96400 (9.83) [21675]	13730 (1.4) [3087]	27460 (2.8) [6174]	26480 (2.7) [5954]	23540 (2.4) [5292]	18630 (1.9) [4190]	54920 (5.6) [12348]	52960 (5.4) [11907]	47070 (4.8) [10584]	37270 (3.8) [8379]	

MEMBER WEIGHTS

Unit: kg (lbs)

Member	Vehicle model	Weight
BATTERY ASSY	See P1-2	
Drive motor ASSY	All Models	Approx. 37 (82)
Pump motor ASSY	All Models	Approx. 31 (68)
Front axle ASSY W/ drive motor ASSY	All Models	Approx. 122 (269)
Rear axle ASSY W/ rear axle cylinder ASSY	All Models	Approx. 45 (99)
Counterweight	7FBE10	Approx. 405 (893)
	7FBE13	Approx. 598 (1319)
	7FBE15	Approx. 697 (1537)
	7FBE18	Approx. 853 (1881)
	7FBE20	Approx. 1040 (2293)
Mast ASSY W/ lift bracket (W/ lift cylinder, L/ fork, Lifting height 3000mm, V mast)	7FBE10 to 7FBE18	330 (730)
	7FBE20	400 (880)
Vehicle weight	7FBE10	2225 (4906)
	7FBE13	2425 (5347)
	7FBE15	2685 (5920)
	7FBE18	2840 (6262)
	7FBE20	3155 (6957)

TOWING THE VEHICLE

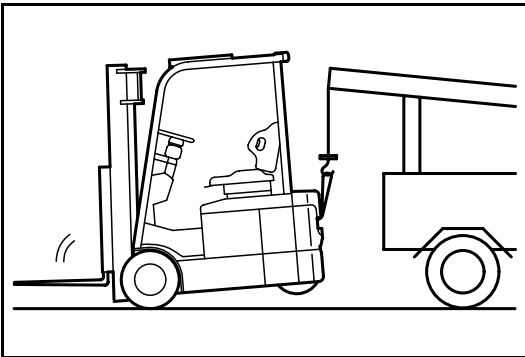

Note the cautions below when towing the vehicle.

1. Lift the rear wheels for towing
2. The traveling speed when towing must not exceed the maximum traveling speed of the forklift.
3. Before starting towing, always set the key switch to OFF and the direction switch to the neutral position.
4. Before towing, either remove the fork or take action to prevent the fork from coming into contact with the ground due to bouncing.

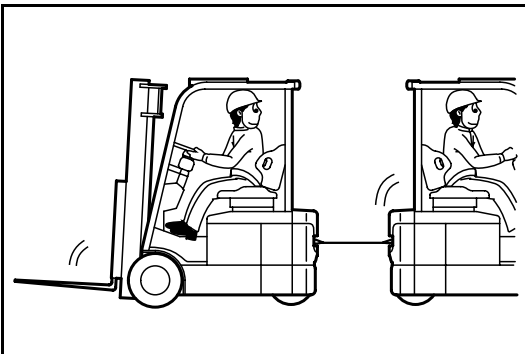

ELECTRICAL PARTS INSPECTION

1. Always disconnect the battery plug before inspecting or servicing electrical parts.
2. Pay sufficient attention when handling electronic parts.

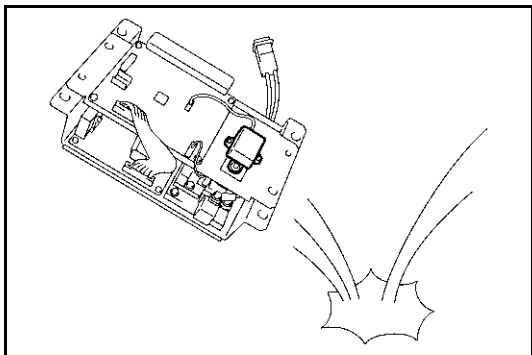

- (1) Never subject electronic parts, such as computers and relays, to impact.
- (2) Never expose electronic parts to high temperature or moisture.
- (3) Do not touch connector terminals, as they may be deformed or damaged due to static electricity.

3. Use a circuit tester that matches the object and purpose of measurement.
 Analog type: This type is convenient for observing movement during operation and the operating condition. Measured value is only a reference

Digital type: A fairly accurate reading is possible. However, it is difficult to observe operation or movement.

- (1) Difference between results of measurement with analog and digital types
 * The results of measurements using the analog type and the digital type may be different.
 Differences between the polarities of the analog type and the digital type are described below.

1) Analog circuit tester

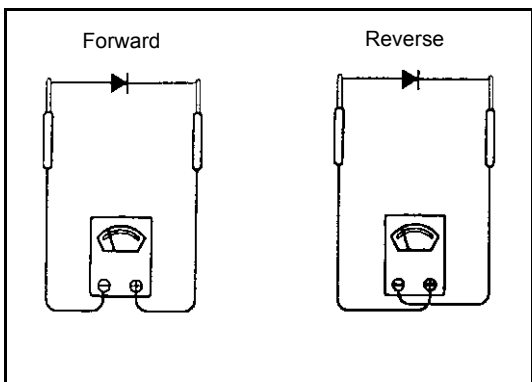

Example of measurement result
 Tester range: kΩ range

	Forward	Analog type
	Reverse	Analog type
Forward		Continuity
		11 kΩ
Reverse		No continuity
		∞

2) Digital circuit tester

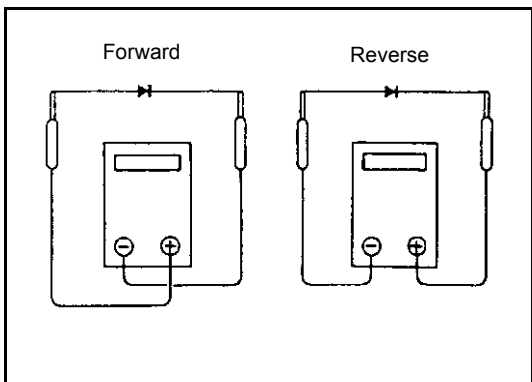

Example of measurement result
 Tester range: 2 MΩ range

	Forward	Digital type
	Reverse	Digital type
Forward		No continuity
		1
Reverse		Continuity
		2 MΩ

(2) Difference in result of measurement with a circuit tester

The circuit tester power supply voltage depends on the tester type. 1.5 V, 3.0 V or 6.0 V is used. The resistance of a semiconductor, such as a diode, varies with the circuit tester power supply voltage.

The diode characteristics are shown in the figure below.

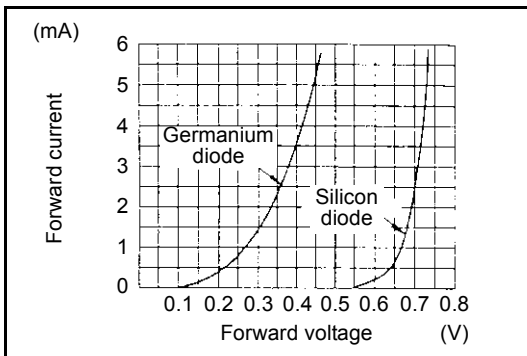

The resistance values of the same semiconductor measured with two types of circuit testers having different power supply voltages are different.

This manual describes the results of measurement with a circuit tester whose power supply voltage is 3.0 V.

(3) Difference in measurement result by measurement range (analog type)

In the analog type circuit tester, changing the measurement range switches over the internal circuit to vary the circuit resistance. Even when the same diode is measured, the measurement result varies with the measurement range.

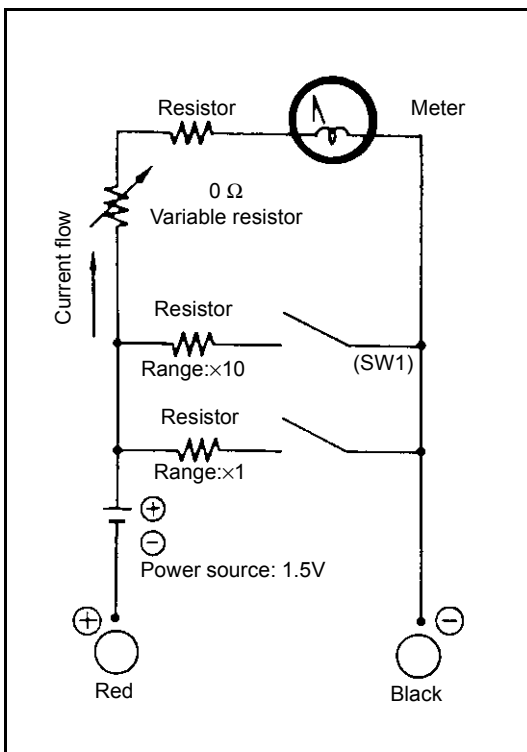

Always use the range described in the repair manual for measurement.

NOTES ON SAS

1. For the explanations of SAS functions and operation, also see “New Model Feature 7FBE10 to 20 Pub. No. PE314”.
2. See page 17-6 FOR REPAIR WORK of this repair manual before servicing.
3. If repair or replacement is performed in any section of the vehicle that relates to SAS function, perform necessary matching to ensure proper SAS function (see page 4-47).
4. always be sure to operate the vehicle carefully. Be aware of the difference in control features between with and without SAS.
5. Many precision valves are used in the SAS oil control valves. When disassembling or replacing hydraulic parts (valves, piping, etc.), be sure to clean the parts before installation. Periodic change of the hydraulic oil is also very important.
6. As the vehicle is equipped with high-precision electronic devices, modification of electrical parts may cause vehicle failure. Be sure to use genuine Toyota parts for replacement and installation of the electrical parts (auxiliary equipment, optional parts, etc.).

STANDARD BOLT & NUT TIGHTENING TORQUE







Tightening torque of standard bolts and nuts are not indicated throughout the manual.

Use the charts and table below to judge the standard tightening torque.

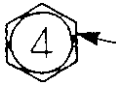
1. Find the class of the bolt strength on the table below and then find the bolt tightening torque on the tightening torque table.
2. The nut tightening torque can be judged from its corresponding bolt type.

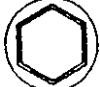
BOLT STRENGTH CLASS IDENTIFICATION METHOD

Identification by bolt shape

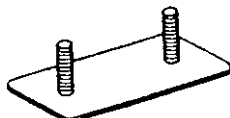
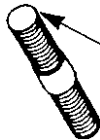
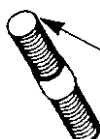
	Shape and class	Class
Hexagon head bolt	 Bolt with raised or etched numeral on head	4 = 4T 5 = 5T 6 = 6T 7 = 7T 8 = 8T
Hexagon bolt		
(standard)	 No mark	4T
Hexagon flange bolt	 No mark	4T
Hexagon head bolt (standard)	 Bolt with two raised lines on head	5T
Hexagon flange bolt	 Bolt with two raised lines on head	6T
Hexagon head bolt (standard)	 Bolt with three raised lines on head	7T
Hexagon head bolt (standard)	 Bolt with four raised lines on head	8T
Welded bolt		4T
Stud bolt	 No mark	4T
	 2 mm groove(s) on one/both edge(s)	6T

Identification by part No.

Hexagon head bolt

Part No.
91611-40625

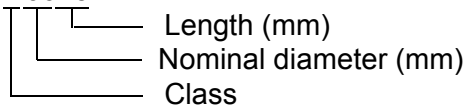

Length (mm)
Nominal diameter (mm)
Class

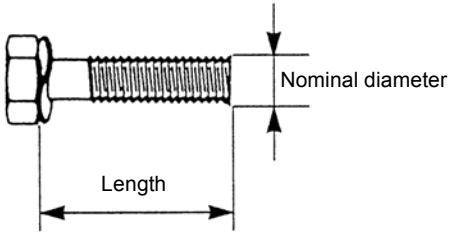

Length
Nominal diameter

Stud bolt

Part No.
92132-40614

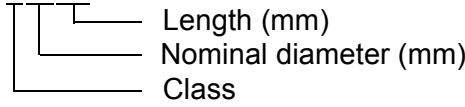

Length (mm)
Nominal diameter (mm)
Class

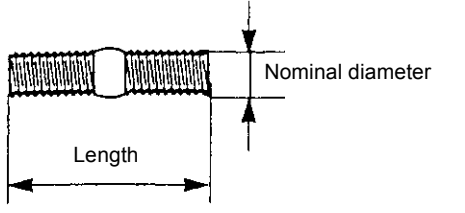

Length
Nominal diameter



**Thank you very much
for your reading.**

**Please click here and go
back to the website.**

**Then, you can
download the complete
manual instantly.**

No waiting.

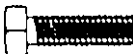
TIGHTENING TORQUE TABLE

Class	Nominal diameter mm	Pitch mm	Standard tightening torque					
			Hexagon head bolt 			Hexagon flange bolt 		
			N·m	kgf·cm	ft·lbf	N·m	kgf·cm	ft·lbf
4T	6	1.0	5.4	55	48in·lbf	5.9	60	52in·lbf
	8	1.25	13	130	9	14	145	10
	10	1.25	25	260	19	28	290	21
	12	1.25	47	480	35	53	540	39
	14	1.5	75	760	55	83	850	61
	16	1.5	113	1150	83	—	—	—
5T	6	1.0	6.4	65	56in·lbf	7.5	75	65in·lbf
	8	1.25	16	160	12	18	175	13
	10	1.25	32	330	24	36	360	26
	12	1.25	59	600	43	65	670	48
	14	1.5	91	930	67	100	1050	76
	16	1.5	137	1400	101	157	1600	116
6T	6	1.0	7.8	80	69in·lbf	8.8	90	78in·lbf
	8	1.25	19	195	14	21	215	16
	10	1.25	38	400	29	43	440	32
	12	1.25	72	730	53	79	810	59
	14	1.5	110	1100	80	123	1250	90
	16	1.5	170	1750	127	191	1950	141
7T	6	1.0	11	110	8	12	120	9
	8	1.25	25	260	19	28	290	21
	10	1.25	52	530	38	58	590	43
	12	1.25	95	970	70	103	1050	76
	14	1.5	147	1500	108	167	1700	123
	16	1.5	226	2300	166	—	—	—
8T	6	1.0	12	125	9	14	145	9
	8	1.25	29	300	22	32	330	24
	10	1.25	61	620	45	68	690	50
	12	1.25	108	1100	80	123	1250	90
	14	1.5	172	1750	127	196	2000	145
	16	1.5	265	2700	195	299	3050	221

PRECOATED BOLTS

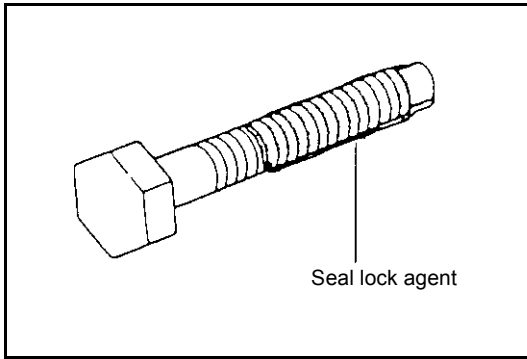

1. Do not replace or restore a precoated bolt as it is in the following cases:
 - (1) After it has been removed.
 - (2) When it has been moved by tightness check, etc. (loosened or tightened)

NOTE:

For torque check, tighten the bolt at the lower limit of the allowable tightening torque range; if the bolt moves, retighten it according to the steps below.

2. How to reuse precoated bolts
 - (1) Wash the bolt and threaded hole.
(The threaded hole must be washed even when replacing the bolt with a new one)
 - (2) Completely dry the washed parts by blowing with air.
 - (3) Apply a specified seal lock agent to the threaded portion of the bolt.

HIGH PRESSURE HOSE FITTING TIGHTENING TORQUE

1. When connecting a high pressure hose, wipe the hose fitting and corresponding nipple contact surfaces with a clean cloth to remove foreign matter and dirt. Also check that there are no dents or other damage on the contact surfaces before installation.
2. When connecting the high pressure hose, hold the hose to align the fitting with the nipple and tighten the fitting.
3. The maximum tightening torque must not exceed twice the standard tightening torque.

Nominal diameter of screw	Tightening torque standard N·m (kgf·cm) [ft·lbf]		Inside diameter of hose mm (in)
	Standard	Tightening range	
7/16-20UNF	25 (50) [18.1]	24 to 26 (240 to 270) [17.4 to 19.5]	6 (0.24)
9/16-18UNF	49 (500) [36.2]	47 to 52 (480 to 530) [34.7 to 38.3]	9 (0.35)
3/4-16UNF	59 (600) [43.4]	56 to 62 (570 to 630) [41.2 to 45.6]	12 (0.47)
7/8-14UNF	59 (600) [43.4]	56 to 62 (570 to 630) [41.2 to 45.6]	12 (0.47)
7/8-14UNF	78 (800) [57.9]	74 to 82 (740 to 840) [53.5 to 60.8]	15 (0.59)
1•1/16-12UNF	118 (1200) [86.8]	112 to 123 (1140 to 1250) [82.5 to 90.4]	19 (0.75)
1•5/16-12UNF	137 (1400) [101.3]	130 to 144 (1330 to 1470) [96.2 to 106.4]	25 (0.98)
PF1/4	25 (250) [18.1]	24 to 26 (240 to 270) [17.4 to 19.5]	6 (0.24)
PF3/8	49 (500) [36.2]	47 to 52 (480 to 530) [34.7 to 38.3]	9 (0.35)
PF1/2	59 (600) [43.4]	56 to 62 (570 to 630) [41.2 to 45.6]	12 (0.47)
PF3/4	118 (1200) [86.8]	112 to 123 (1140 to 1250) [82.5 to 90.4]	19 (0.75)
PF1	137 (1400) [101.3]	130 to 144 (1330 to 1470) [96.2 to 106.4]	25 (0.98)