

Document Title: Component locations	Function Group: 200	Information Type: Service Information	Date: 2014/3/21
Profile: WLO, L60G [GB]			

Component locations

Engine, component positions

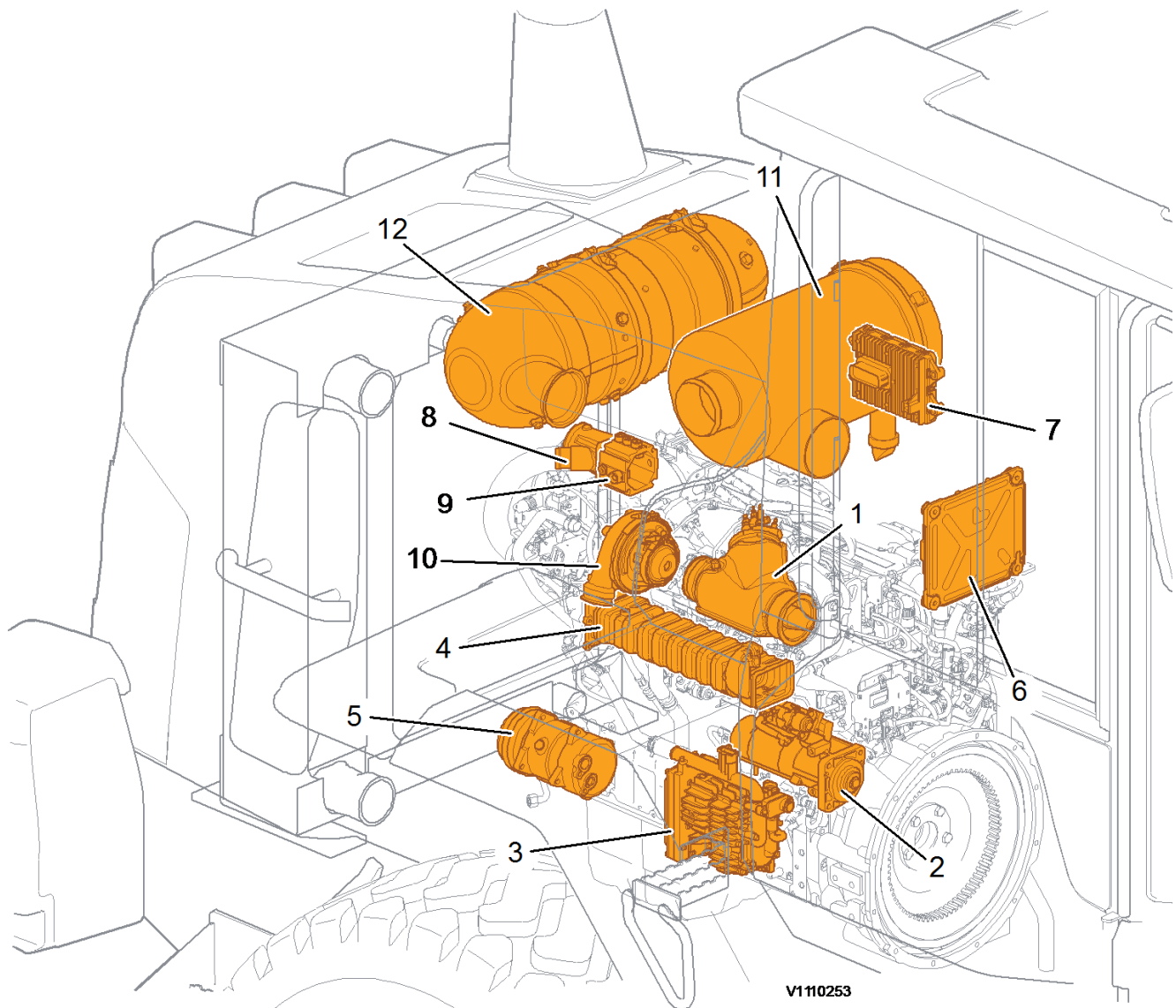
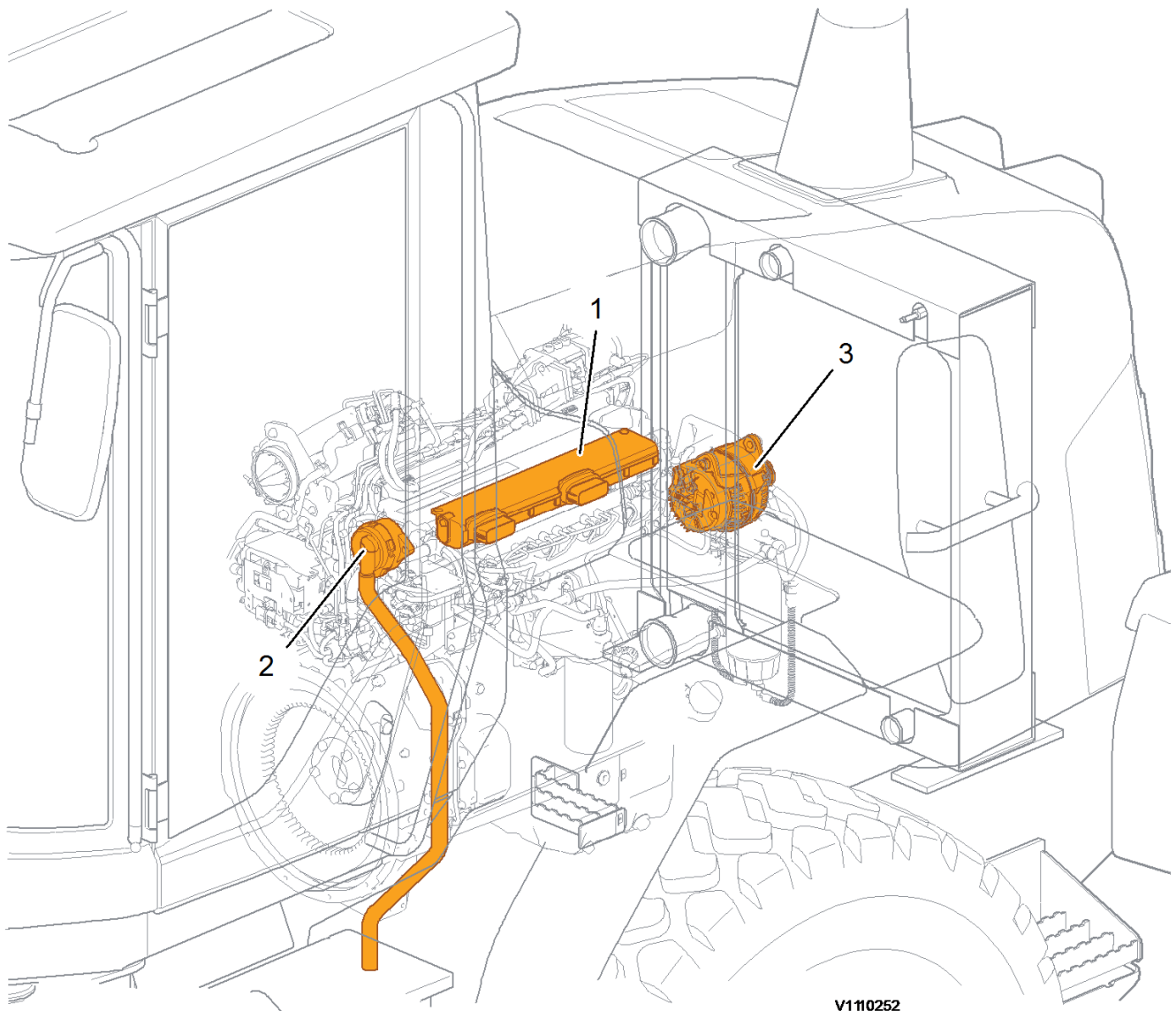

Figure 1

1. Burner
2. Starter motor
3. Air pump
4. EGR-cooler
5. AC compressor
6. E-ECU
7. ACM
8. Mixing chamber

9. Preheater
10. Turbocharger
11. Air cleaner
12. Muffler



V1110252

Figure 2

1. Electrical connections, grouping point
2. Crankcase ventilation, separator
3. Alternator

Document Title: VCADS Pro, Operations	Function Group: 200	Information Type: Service Information	Date: 2014/3/21
Profile: WLO, L60G, L70G, L90G [GB]			

VCADS Pro, Operations

The following VCADS Pro operations are available for function group 2. Operations used when changing or working on components are mandatory.

Tests

Operation	Application
21006-3 Cylinder compression, test	Used when there is a suspicion of fault and/or at abnormal values/readings. This test indicates if there is any deviation in compression in any cylinder in relation to the other cylinders. As a first check this operation is both easy and fast to perform instead of a real compression test.
23017-3 Feed pressure, inspection	Used when there is a suspicion of fault and/or at abnormal values/readings.
23712-3 Injectors shut off, manual	Used when there is a suspicion of fault and/or at abnormal values/readings.
25410-3 Air pump exhaust aftertreatment, test	Used when there is a suspicion of fault and/or at abnormal values/readings.
25411-3 Burner exhaust aftertreatment, test	Used when there is a suspicion of fault and/or at abnormal values/readings.
25412-3 Components ASU, test	With this sub-test, the functions of the atomiser air valve, the main air valve, the fuel shut-off valve and the fuel pump are checked.
25457-3 Diesel Particulate Filter Service Regeneration	Used when the soot load is over 1.7. See 254 Exhaust Aftertreatment System, description Before starting service regeneration check the differential pressure over the diesel particle filter so that it is within stated value according to the service information. This is to make sure that the DPF won't get damaged by the service regeneration. After the service regeneration and when the exhaust temperature has stabilized to a normal level check the differential pressure over the DPF again so that it is within stated value according to the service information. This is to determine that the filter has been regenerated correctly and that it is not clogged with ash.
26385-3 Reversible cooling fan, test	When there is a suspicion of fault and/or at abnormal values/readings.
27102-3 Accelerator pedal, test	At abnormal values/readings.
28407-3 Sensor values, monitoring	When there is a suspicion of fault and/or at abnormal values/readings.
28420-3 Flywheel and camshaft signal, test	Used when there is suspicious of faulty signals or faulty connected sensor.
29332-3 Exhaust gas circulation, function test	Used when there is a suspicion of fault and/or at abnormal values/readings.

Programming

Operation	Application
25801-3 MID 233 Control unit, programming	When changing ACM or only reprogramming. See 254 ACM, replacing, non-programmed
28423-3 MID 128 ECU, programming	When changing ECU or only reprogramming. See 200 E-ECU, MID 128, changing non-programmed ECU

Document Title: Engine belts, replacing	Function Group: 200	Information Type: Service Information	Date: 2014/3/21
Profile: WLO, L60G [GB]			

Engine belts, replacing

Op nbr 200-200

1. Place the machine in service position according to [191 Service position](#).
2. Open the engine hood.
3. Remove the plastic protection (24 screws).



Figure 1

1. Plastic protection
4. Remove the AC-belt (3 screws).

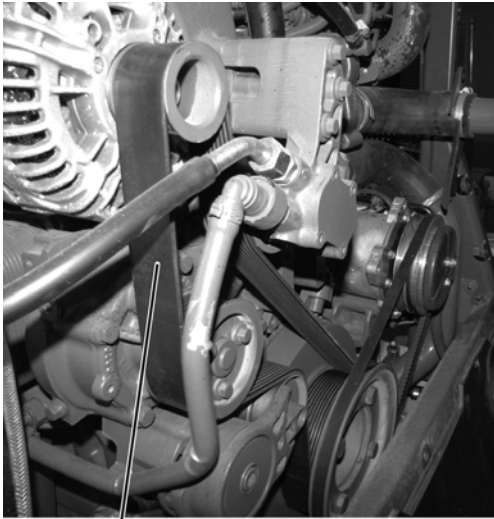

1

V1110572

Figure 2

1. Alternator belt

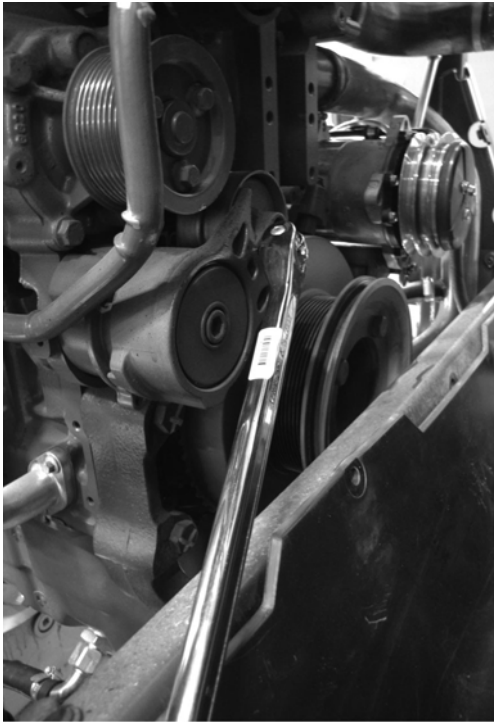

V1110582

Figure 3

Loosen the tensioning pulley and remove the belts.

5. Remove the alternator belt.

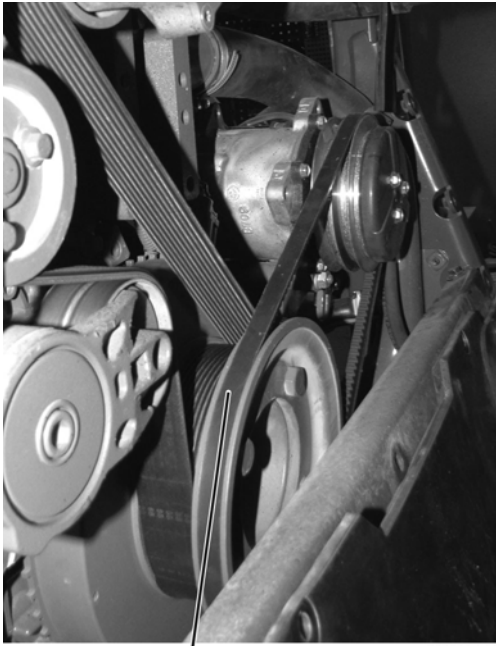

1

V1110573

Figure 4

1. AC-belt
6. Install new alternator belt and AC-belt.
7. Install the plastic protection.
8. Restore the machine.

Document Title: Compression test	Function Group: 210	Information Type: Service Information	Date: 2014/3/21
Profile: WLO, L60G [GB]			

Compression test

Op nbr 210-002

[885812 Timing tool](#)

[9988539 Pressure gauge](#)

[88800070 Spanner](#)

[88830197 Rotation tool](#)

[88830205 Adapter](#)

[88830206 Counterhold](#)

This operation also includes required tools and times for applicable parts of the following operations:

[214 Valves, adjusting](#)

NOTICE

Maintain greatest possible cleanliness when working on the fuel system.

1. Place the machine in service position 1, see: [191 Service position](#)

2. Open the engine hood.

3. **NOTICE**

Plug all pipes, hoses and connections when removing.

4. Unplug the connector and remove the hoses (2 pcs.) between the air cleaner and the turbo (3 clamps).

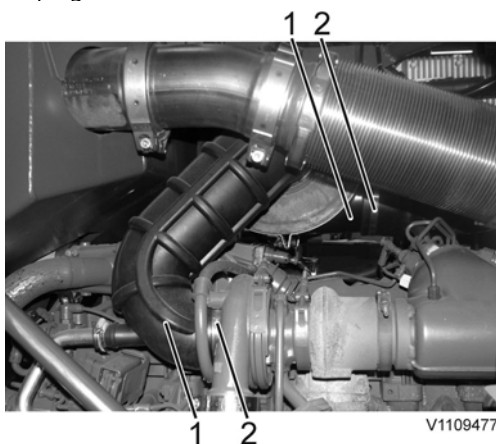

Figure 1

1. Hoses
2. Clamps

5. Remove the bracket for the air cleaner (2 clamps).
Remove the air cleaner.

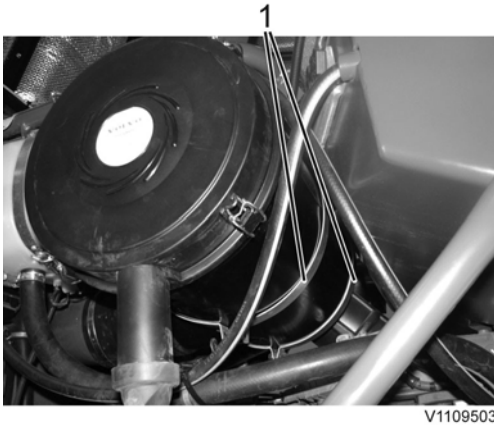

Figure 2

1. Clamps

6. Remove the dust cover between the valve cover and the inlet pipe. Unplug the connector and remove the control unit (3 screws).

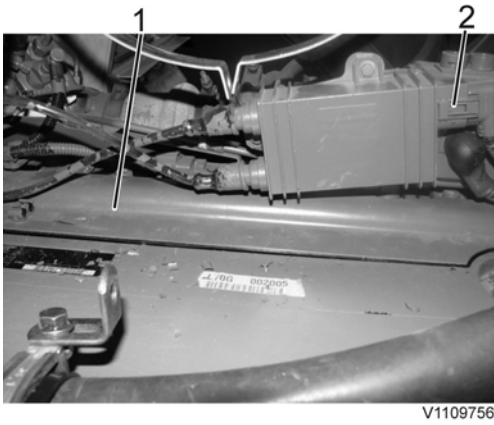

Figure 3

1. Dust cover
2. Connector

7. Unplug the connectors (2 pcs.) Remove the screws (2 pcs.) for the cable holder. Place the cable holder in appropriate work position.

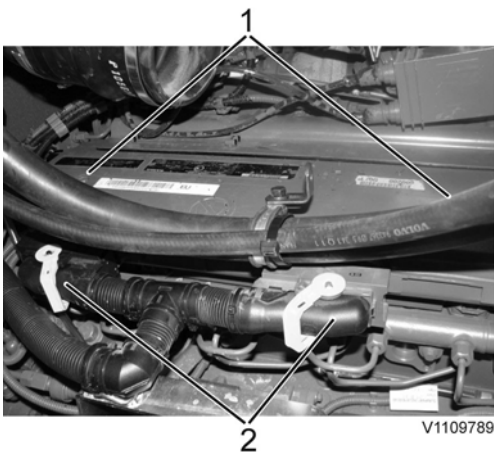

Figure 4

1. Bolt
2. Connectors

8. Unplug the connectors (2 pcs.) for the injectors.



Figure 5

1. Connector

9. Remove the crankcase ventilation (2 bolts) and the valve cover (14 bolts).

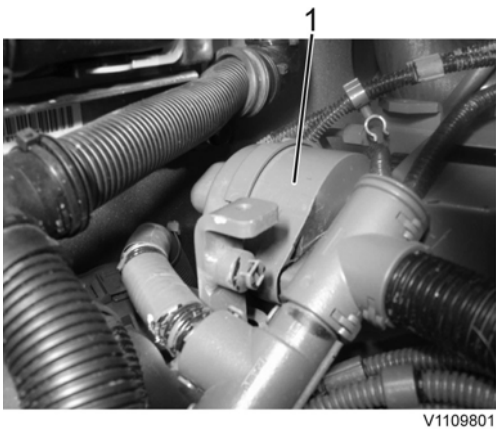

Figure 6

1. Crankcase ventilation

10. Unplug the connectors (2 pcs.) for the FCV and the high-pressure pump.

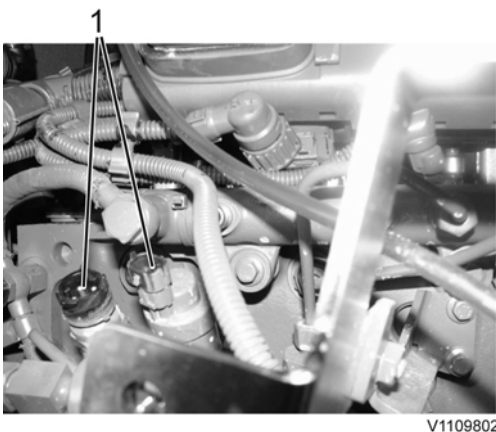

Figure 7

1. Connectors

11. Install 88800070 Spanner to remove the injector pipes (6 pcs.) and the rail pipes (2 pcs.) from the pump.

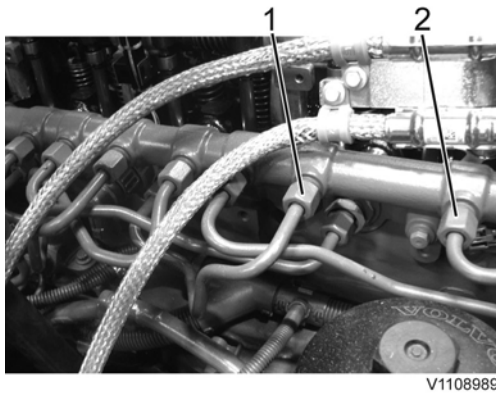

Figure 8

1. Rail pipe
2. Injector pipe

12. Remove the feed line. Attach a 10 mm (0.4 in.) hose to the feed line for circulating the fuel to the tank.

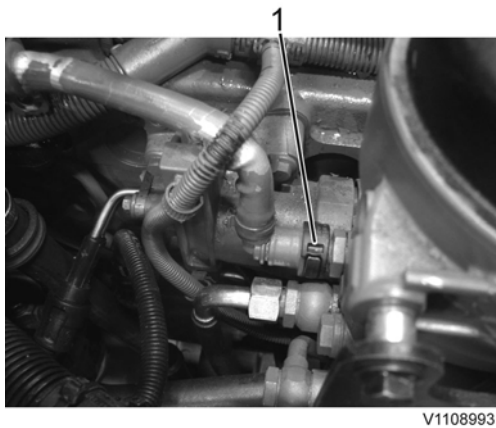

Figure 9

1. Feed line



Figure 10

1. Hose for fuel circulating
13. Remove the nut (6 pcs.) and the nozzle (6 pcs.) for the injector (6 pcs).

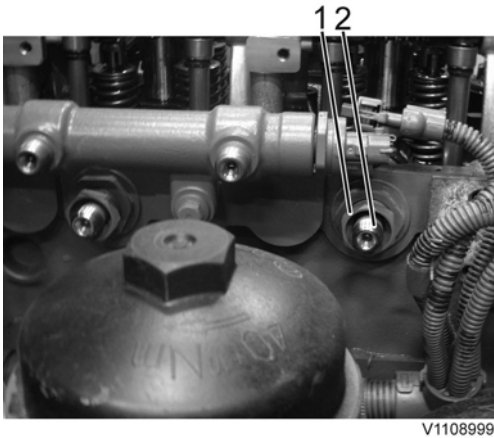

V1108999

Figure 11

1. Nut
2. Nozzle
14. Disconnect the electric connections (12 pcs.) from the injectors and remove the screws (6 pcs.) for the bracket. Remove the cable harness (2 screws).

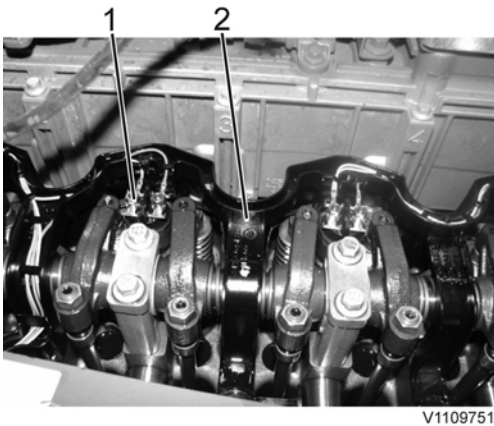

V1109751

Figure 12

1. Electric connections
2. Cable harness
15. Replace the injector, use: 88830206 Counterhold.

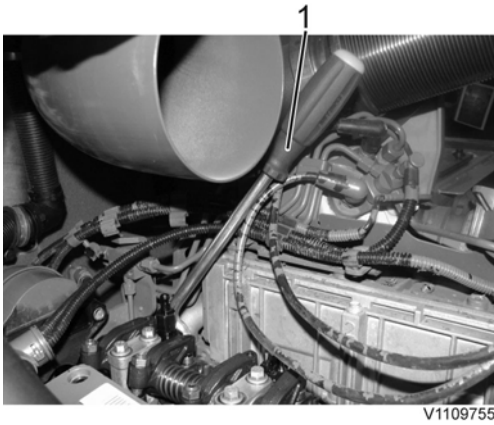

Figure 13

1. 88830206 Counterhold

NOTE!

The engine must cool down for approx. 30 minutes and the oil temperature must not exceed 80 °C (176 °F).

16. Check that the valve clearances are correct, adjust as needed, see: [214 Valves, adjusting](#).
17. Install the compression test equipment: 88830205 Adapter, 9988539 Pressure gauge. Run the engine with the starter motor for 5–10 seconds. Repeat the procedure for all the other cylinders. The difference in compression pressure should not exceed 15%.

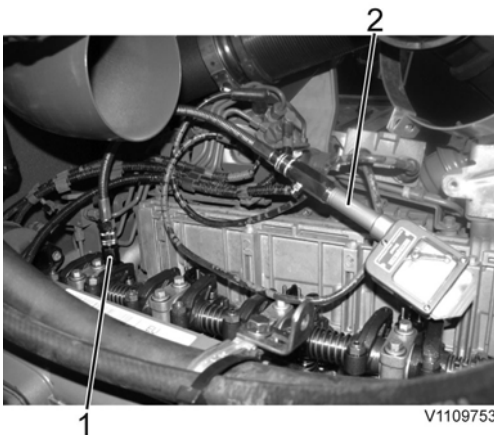

Figure 14

1. 88830205 Adapter
2. 9988539 Pressure gauge

18. Remove the compression test equipment.
19. Install the injectors with new copper gaskets. Install the nut and the nozzle for the injectors. Tightening torque, attaching yoke, see: [230 Tightening torque, fuel system](#)
20. Connect the electric connections for the injectors. Install the cable harness.
21. Install new fuel delivery lines. Tightening torque, see: [230 Tightening torque, fuel system](#)
22. Remove the hose between the fuel feed pump and the fuel tank. Connect the fuel hose to the fuel feed pump.
23. Plug in the connectors for the FCV and the high-pressure pump.

24. Install the valve cover and the crankcase ventilation. Tightening torque, see: [214 Valve system, specification](#)
25. Plug in the connectors for the injectors.
26. Install the cable holder, control unit, dust cover, and the air cleaner with clamps.
27. Plug in the connector and install the hoses between the air cleaner and the turbo.
28. Bleed the fuel system, see: [233 Fuel system, bleeding](#)

 **WARNING**

Make sure that high-pressure fuel cannot come into contact with unprotected parts of the body when working with injection equipment.

29. Restore the machine.

Document Title: Engine rotation speed sensor (crank shaft), replacing	Function Group: 210	Information Type: Service Information	Date: 2014/3/21
Profile: WLO, L60G [GB]			

Engine rotation speed sensor (crank shaft), replacing

Op nbr 210-093

1. Place the machine in service position according to [191 Service position](#).
2. Open the engine hood.
3. Unplug the connector and loosen the screw that holds the speed sensor.

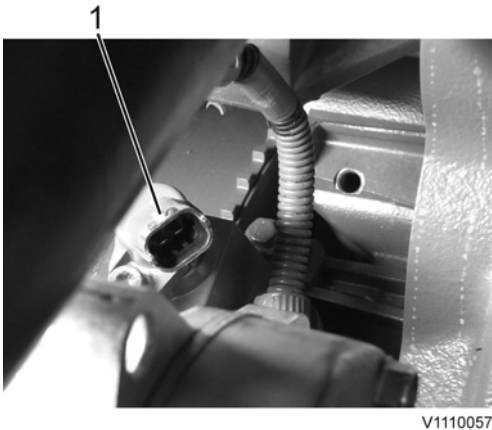

Figure 1

1. Connector

4. Remove the speed sensor.

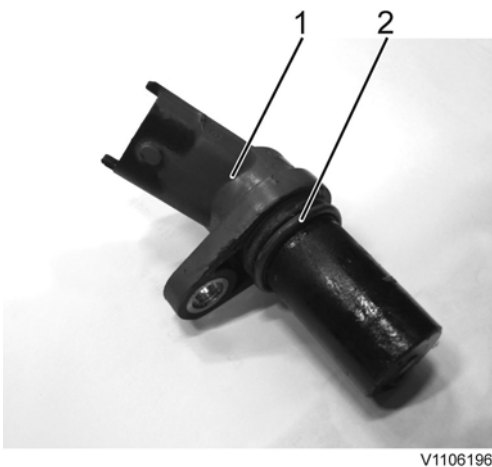

Figure 2

1. Loose speed sensor
2. O-ring

5. Replace the O-ring.
6. Install a new speed sensor and plug in the connector.
7. Restore the machine.

Document Title: Engine rotation speed sensor (camshaft), replacing	Function Group: 210	Information Type: Service Information	Date: 2014/3/21
Profile: WLO, L60G [GB]			

Engine rotation speed sensor (camshaft), replacing

Op nbr 210-092

1. Place the machine in service position according to [191 Service position](#).
2. Open the engine hood.
3. Remove the oil pipe (2 screws).

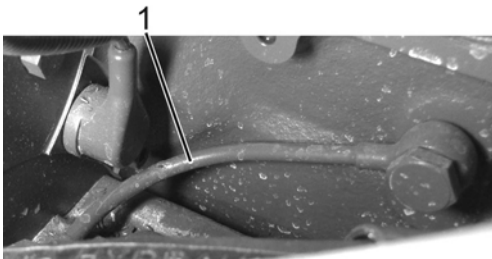

V1110129

Figure 1

1. Oil pipe
4. Cut the cable tie, unplug the connector and loosen the screw that holds the speed sensor.



V1110071

Figure 2

1. Connector
5. Remove the speed sensor.

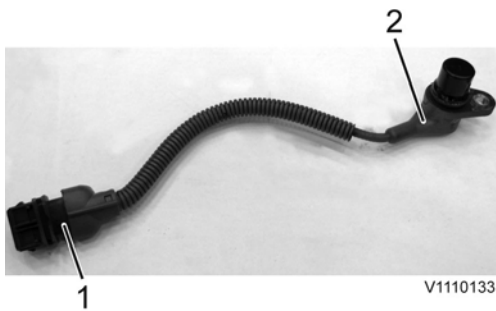

Figure 3

1. Connector
2. Speed sensor
6. Replace the O-ring.
7. Install a new speed sensor and plug in the connector.
8. Install the oil pipe. Tightening torques:
 - M12 (banjo screw): **20 ± 3 Nm (14.8 ± 2.2 lbf ft)**
 - M16 (banjo screw): **40 ± 5 Nm (29.5 ± 3.7 lbf ft)**
9. Restore the machine.

Document Title: Crankcase ventilation, description	Function Group: 212	Information Type: Service Information	Date: 2014/3/21
Profile: WLO, L60G [GB]			

Crankcase ventilation, description

Since some of the combustion pressure enters the crankcase after passing by the pistons and piston rings (blow-by), the crankcase must be ventilated.

The purpose of the crankcase ventilation is to balance the pressure in the crankcase in order to avoid damage to engine components and to prevent oil mist formation and oil leakage into the ambient air.

The crankcase ventilation consists of a housing containing a filter, with connections to the oil sump and ventilation piping.

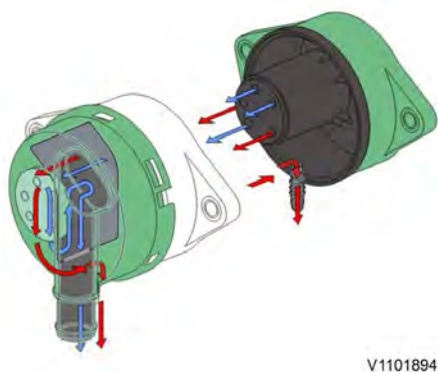

Figure 1
Crankcase ventilation housing

Air containing oil particles comes from the crankcase via the cylinder head into the crankcase ventilator. The air (blue arrows) passes through the filter, while oil particles (red arrows) are caught and led back to the oil sump via a return pipe.

Supplementary information

- [200 Engine, description](#)
- [200 Component locations](#)

Document Title: Valves, adjusting	Function Group: 214	Information Type: Service Information	Date: 2014/3/21
Profile: WLO, L60G [GB]			

Valves, adjusting

Op nbr 214-012

[88830207 Rotation tool](#)

[885812 Timing tool](#)

NOTE!

The engine must cool down for approx. 30 minutes and the oil temperature must not exceed 80 °C (176 °F).

NOTICE

Never adjust the valves with the engine running as the valves may strike the piston and cause serious damage.

1. Place the machine in service position, see [191 Service position](#).
2. Lift the hood.
3. Remove the lower part of the intermediate wall. Place the rotation tool over the attaching bolts for the belt pulley.



V1108703

Figure 1
Intermediate wall

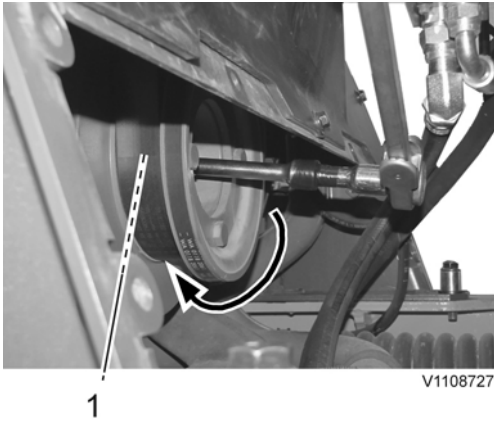

Figure 2

4. Unplug the main connectors, remove the two screws and move aside the cable conduit. Unplug the injector connectors. Remove the steel straps and move aside the two coolant hoses. Remove the screws and move aside the spark plug control unit.

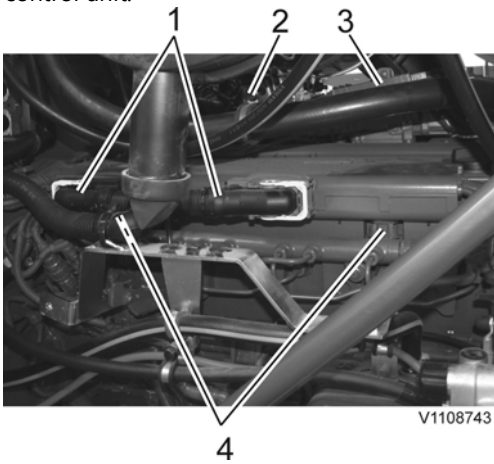

Figure 3

1. Main connectors
2. Clamp for coolant hoses
3. Spark plug control unit
4. Injector connectors

5. In order to access the attaching bolts for the valve cover, unplug the connector for SE2524 and remove the crankcase ventilation housing. Move the cables aside.



Figure 4

1. Bolts for oil trap
2. SE2524

6. Remove the plastic cover panel. It is only fastened with clips. Loosen the two sensor cables to access to the valve cover's bolts.

NOTICE

Carefully clean around the valve cover to prevent dirt and debris from getting into the engine while work is in progress.

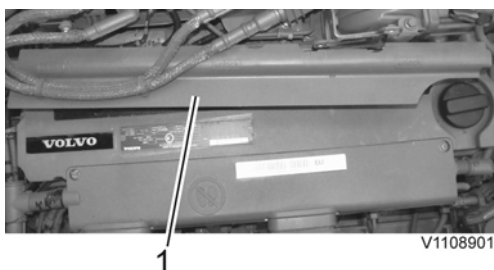

Figure 5

1. Plastic cover panel

Remove the valve cover's bolts. Part the clamp for the air filter. Remove the valve cover.

NOTE!

The valve cover gasket is vulcanized together with the cable channel. Be careful when removing the valve cover. Make sure that the valve cover's gasket remains on the engine.

7. Crank the engine to a position where the valves on the cylinder number 1 (**closest to the flywheel side**) overlap. Overlapping means that the exhaust valve is about to open and the inlet valve is about to close. In this position it should not be possible to rotate any of the push rods by hand for the cylinder in question.

Thank you very much for reading.

This is part of the demo page.

GET MORE:

Hydraulic

System, Setting

Instructions, Functional

Description, Electrical

System And more.....

Click Here BUY NOW

Then Instant Download

the Complete Manual.

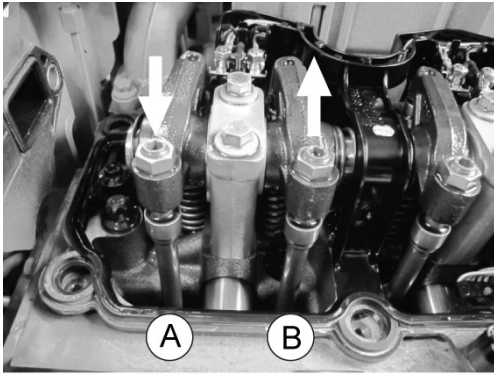

V1106953

Figure 6

- A. — Exhaust valve
- B. — Inlet valve

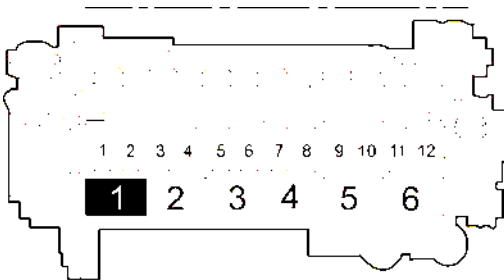

V1003317

Figure 7

- 1, 3, 5, 7, 9, 11 are exhaust valves
- 2, 4, 6, 8, 10, 12 are inlet valves

8. Mark the position on the belt pulley and oil pump's cover.
9. Adjust the valve clearance for each cylinder according to **the black markings** in the figure. Procedure for adjusting:
 1. Loosen the adjusting screw's lock screw on the rocker arm.
 2. Install the timing tool on the adjusting screw.
 3. Turn the adjusting screw until zero clearance is obtained between rocker arm and valve. Set the timing tool to zero.
 4. Turn the adjusting screw **counter-clockwise 75° ±10% for inlet valve** and **120° ± 10% for exhaust valve**
 5. Hold the adjusting screw in position and at the same time tighten the lock nut. Tightening torque: See [210 Engine, tighten torques](#)

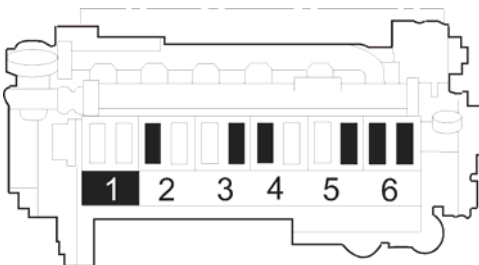

V1003318

Figure 8

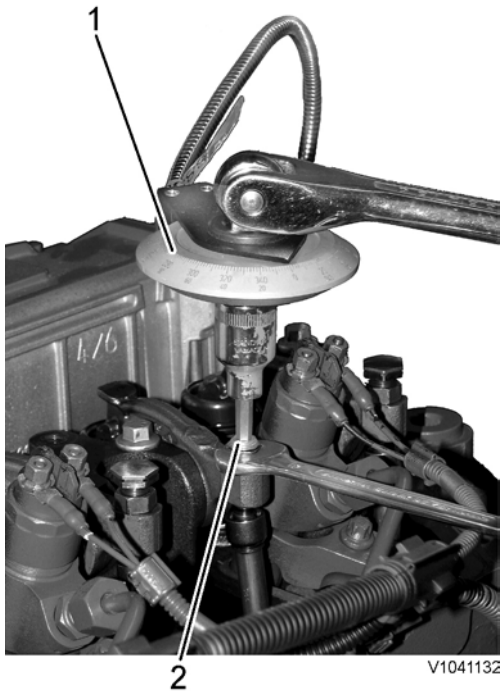

Figure 9
Use of timing tool, principle

1. 885812 Timing tool
2. Adjusting screw

10. Turn the crankshaft one more revolution until the valves for cylinder number 6 overlap. Adjust the valve clearance for each cylinder according to **the black markings** in the figure.

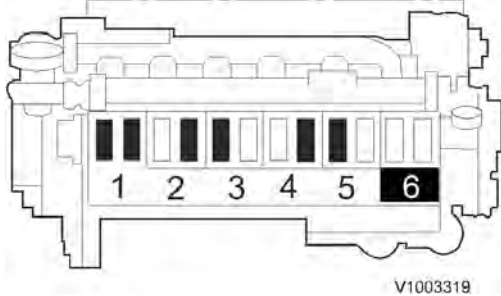

Figure 10

11. Clean all sealing surfaces.
12. Install the valve cover. Tightening torques, see [210 Engine, tighten torques](#)
13. Install the crankcase ventilation housing and connect SE2524. Plug in the main connectors and the injector connectors and install the cable conduit.
14. Install the spark plug control unit and the sensor cables which were moved aside. Install the clamp for the air filter and fasten the coolant hoses. Install the plastic cover panel.
15. Remove the rotation tool and install the intermediate wall.