

Document Title: General description	Function Group: 400	Information Type: Service Information	Date: 2014/3/27
Profile: WLO, L60E [GB]			

General description

Power from the engine is transferred hydraulically and mechanically to the wheels through the transmission, via a torque converter that adapts the output torque to the required torque and on to the drive axles.

The hydraulic transmission is of type HT93.

HT93 is a hydromechanical four-speed transmission (Power Shift) with torque converter, spur gears and hydraulically operated disc clutches.

It has four forward and four reverse gears.

The clutch drums for the different gears rotate freely on the clutch shafts. When a gear is engaged, the clutch drum that is transmitting the power is mechanically connected to respective clutch shaft of the hydraulically affected disc clutches. The mechanical power transmission in the hydraulic transmission takes place via gears in constant mesh.

The drive axles have floating axle shafts and planetary gear hub reductions with integrated oil-cooled disc brakes. The axles have an oil space shared by the hub reductions, brake discs and final drive.

The axles have the designation AWB15.

Document Title: Description	Function Group: 414	Information Type: Service Information	Date: 2014/3/27
Profile: WLO, L60E [GB]			

Description

Torque converter

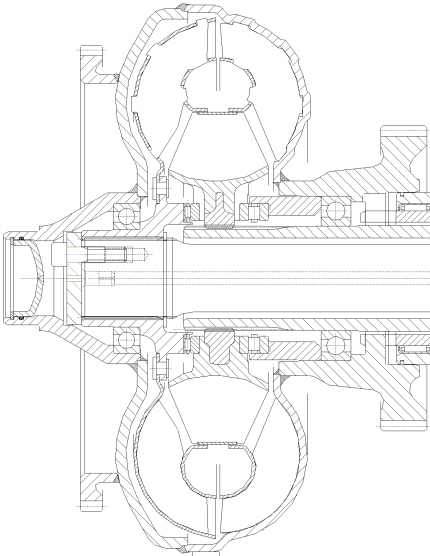

Figure 1

Torque converter

The torque converter consists of an engine-driven impeller and a turbine rotor that drives the transmission's mechanical part, the gearbox. A fixed stator is located between the impeller and the rotor.

Function

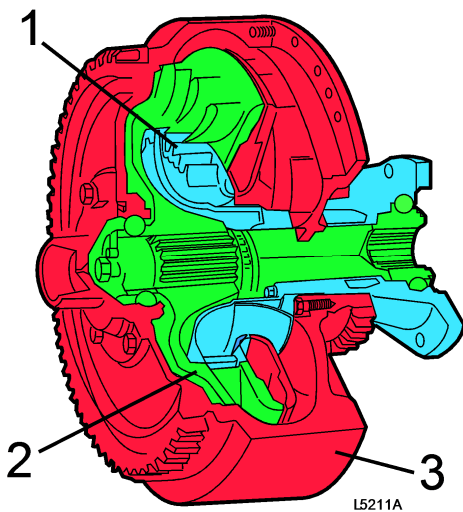

Figure 2
Principle diagram

1. Stator
2. Turbine rotor
3. Pump rotor

The red guide rails designate the pump rotor, which is run by the engine. The red arrow shows the direction of rotation. The green guide rails designate the turbine rotor, which is connected to the transmission. The blue guide rails designate stators, while the black arrows indicate oil flow. The pump and turbine rotors can rotate freely and individually. If we imagine that the torque converter is filled with oil and the pump rotor is rotating, oil will flow as indicated by the thicker arrows. Suppose the turbine rotor is stationary. Almost all of the kinetic energy the oil receives from the pump, after leaving the pump, remains. When the oil returns to the pump rotor, it receives an additional boost of kinetic energy. At maximum oil speed, the turbine rotor torque will be three times greater than the torque supplied by the pump rotor. When the turbine rotor speed equals that of the pump rotor, torque increase is almost nil (smaller arrows).

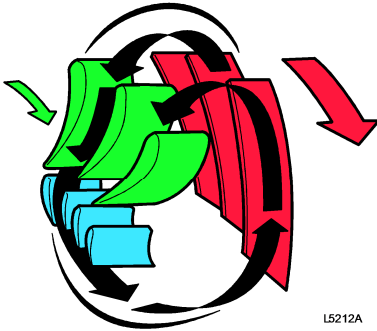

Figure 3
Principle diagram

The pump rotor speed is high; the turbine is stationary or rotates slowly. The eddy current, and thereby the torque increase, is greatest.

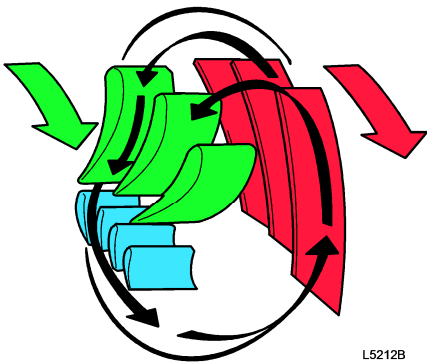

Figure 4
Principle diagram

The pump rotor and turbine speeds are almost identical. The eddy current and subsequent torque increase is least.

Document Title: Hydraulic transmission, description	Function Group: 421	Information Type: Service Information	Date: 2014/3/27
Profile: WLO, L60E [GB]			

Hydraulic transmission, description

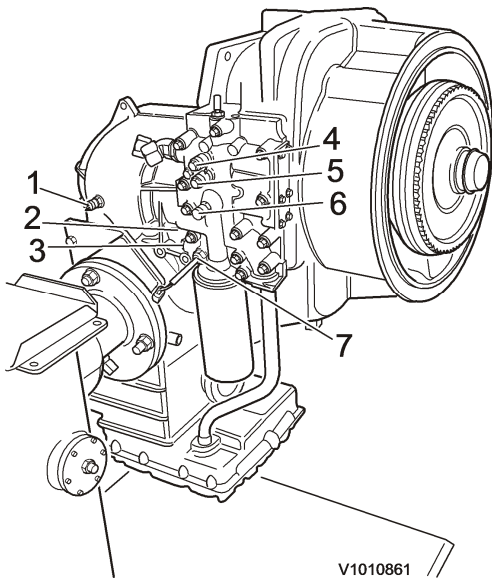

Figure 1

1. SE403, output rpm, speed
2. SE401, pressure monitor, clogged transmission oil filter
3. SE405, transmission oil pressure
4. Pressure check connection, lube oil pressure
5. Pressure check connection, torque converter pressure
6. Pressure check connection, main pressure
7. SE406, sensor transmission oil temperature

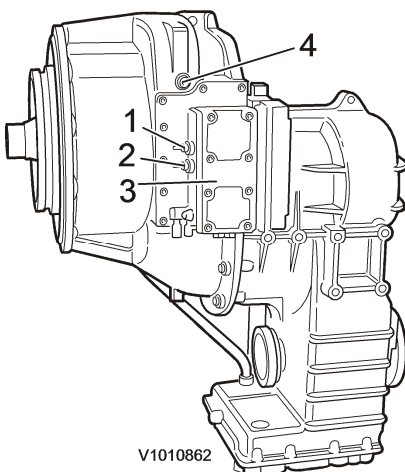

Figure 2

1. Forward/Reverse slide
2. Drive position slide
3. Gear selector valve
4. SE201, input rpm, engine rpm

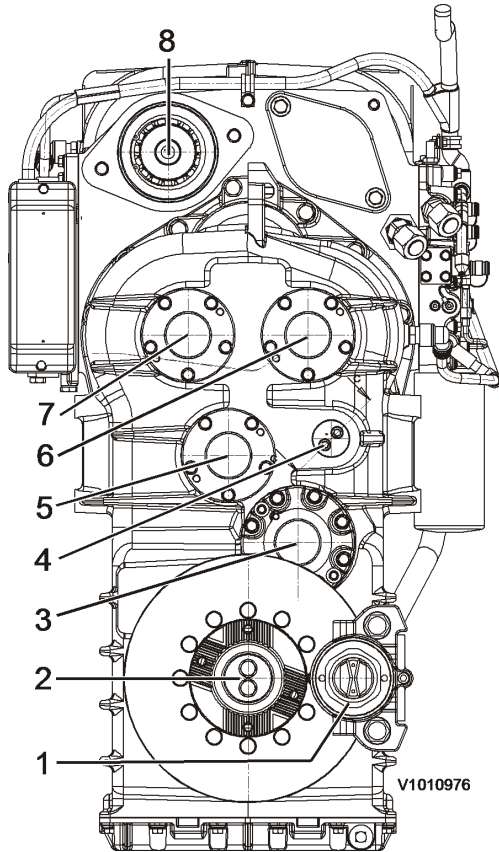

Figure 3

1. Parking brake
2. Output shaft
3. Countershaft (intermediate shaft)
4. 2nd gear transfer gear shaft
5. Clutch shaft 1st – 2nd
6. Clutch shaft Reverse – 4th
7. Clutch shaft Forward – 3rd
8. Power take-off

Symbol diagram neutral position, transmission

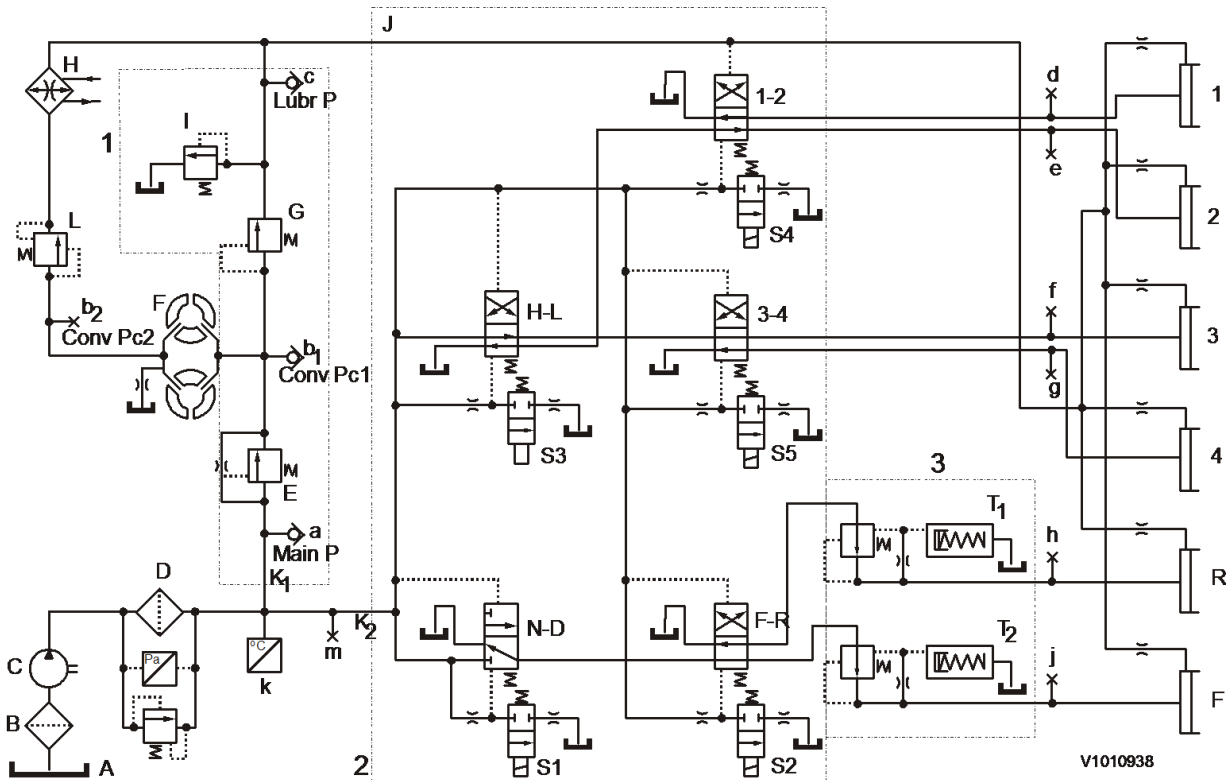

Figure 4

Symbol diagram, neutral position

- A Oil tank
- B Strainer
- C Pump
- D Filter, with filter indicator SE401
- E Pressure limiting valve (main pressure)
- F Torque converter
- G Safety valve (torque converter pressure)
- H Oil cooler
- I Pressure limiting valve (lube oil pressure)
- J Lube oil line
- K1 Pressure line, pressure control valve
- K2 Pressure line, gear selector valve
- L Pressure back-up valve
- S1 Solenoid and gear slide, neutral and drive
- S2 Solenoid and gear slide, forward and reverse
- S3 Solenoid and gear slide, (3rd-4th) – (1st-2nd)
- S4 Solenoid and gear slide, 2nd and 1st
- S5 Solenoid and gear slide, 3rd and 4th
- T1 Reverse gear's damping valve
- T2 Forward gear's damping valve

Pressure check connections and connections

- a Pressure check connection, main pressure (quick-coupling)
- b1 Pressure check connection, torque converter pressure (quick-coupling)
- b2 Pressure check connection, torque converter pressure (plug on pressure control valve)
- c Pressure check connection, lube oil pressure (quick-coupling)
- d Pressure check connection, clutch 1st
- e Pressure check connection, clutch 2nd
- f Pressure check connection, clutch 3rd
- g Pressure check connection, clutch 4th
- h Pressure check connection, reverse clutch
- j Pressure check connection, forward clutch
- k Temp. sensor, SE406
- m Pressure sensor, SE405
- 1 Pressure control valve
- 2 Gear selector valve
- 3 Damping valve

Block diagram neutral position, transmission

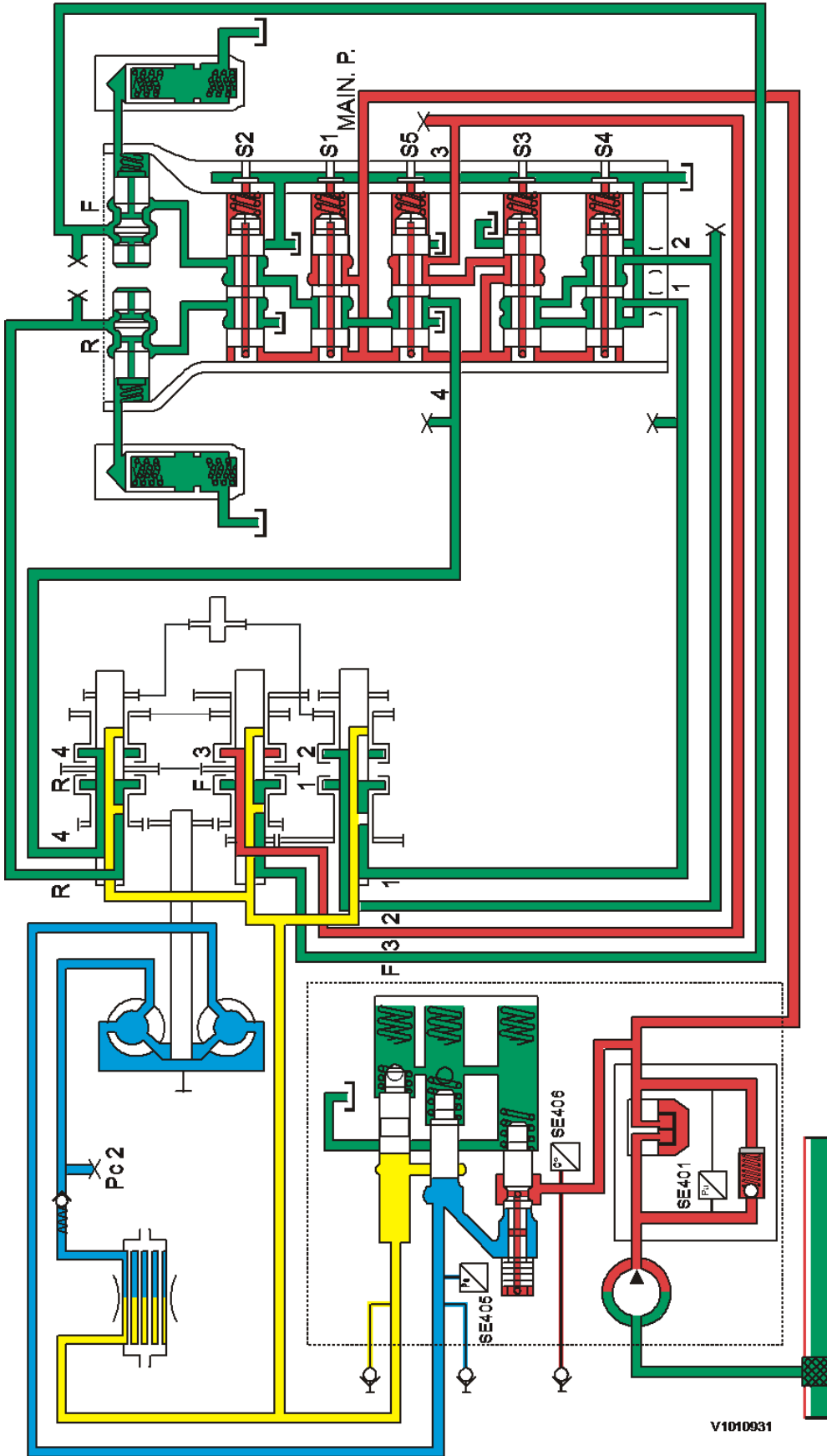
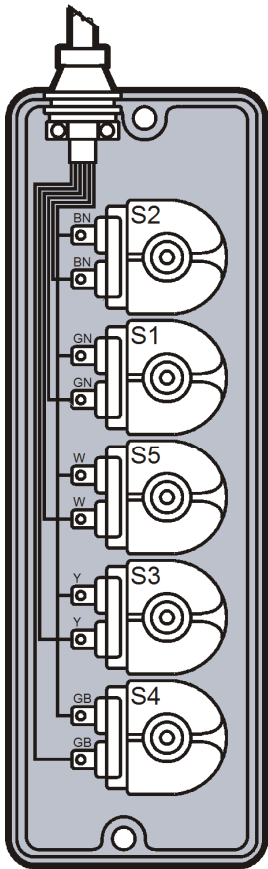

Figure 5

Colour designation

Red	Clutch pressure
Blue	Torque converter pressure
Yellow	Lube oil pressure
Green	Atmospheric pressure

Shifting diagram



GEAR	SOLENOID				
	S1	S2	S3	S4	S5
1F	●		●	●	
2F	●		●		
3F	●				
4F	●				●
N					
1B	●	●	●	●	
2B	●	●	●		
3B	●	●			
4B	●	●			●

V1010932

Figure 6

Document Title: Transmission, fault diagnosis	Function Group: 421	Information Type: Service Information	Date: 2014/3/27
Profile: WLO, L60E [GB]			

Transmission, fault diagnosis

The machine has insufficient pulling power

If the machine has insufficient pulling power the fault could be found in the engine or transmission.

Check engine stalling speed, see Section 2.

Verify hydraulic pressure is not outside of the specification limits and that the brakes are not applied (service brake or parking brake).

1. If the stalling speed is too low, the fault can be found in the engine.
2. If the engine stalling speed is within or higher than the specified limits, the fault can be found in the transmission.
 - Check that 1st gear can be engaged.
 - Insufficient pulling power in combination with the transmission running hot indicates a fault in the torque converter. Start by checking torque converter pressure.

Shifting gears is not possible

Gear engagement failure may be caused by:

- Electrical malfunction.
- Defective gear selector valve
- Hydraulic or other fault in the clutch shaft

Check the main pressure and the clutch pressure for the clutch in question.

- If the correct clutch pressure is obtained, the fault is in the clutch (slipping).
- Correct main pressure and low clutch pressure could be due to leakage between the oil distributor and clutch shaft or in the gear selector valve.
- If the correct main pressure is obtained but no clutch pressure is present, an electrical fault or a fault in the gear selector valve could be the cause.

A temporary functional disorder (pressure loss) could be due to:

- Electric malfunction (loose connection) etc.
- Binding valve spool in the gear selector valve.
- Leakage between oil distributor and clutch shaft (functions when the oil is cold, malfunctions when the oil heats).

Document Title: Gear selector valve, removing and installing	Function Group: 421	Information Type: Service Information	Date: 2014/3/27
Profile: WLO, L60E [GB]			

Gear selector valve, removing and installing

Op nbr 42108

Park the machine in service position.

Removing

1. Remove the front part of the rear fender on the right side.
Weight, front part of rear fender: **approx. 25 kg (55 lbs)**
2. Remove the tool box and the steps (ladder) on the right side.
Weight: **approx. 55 kg (121 lbs)**
3. If the machine is equipped with electric lever lock (4th hydraulic function) and attachment lock, the solenoid valve block with MA912 and MA913 shall be removed.

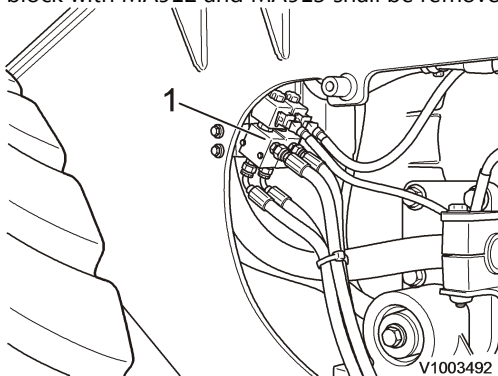

Figure 1

1. Solenoid valve block, MA912, MA913

4. Remove the clamp in the frame for the large cable harness behind the gear selector valve.

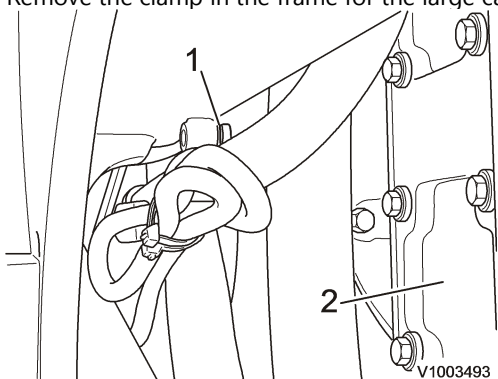

Figure 2

1. Clamp

2. Gear selector valve

5. Remove the cover on the gear selector valve as well as the cabling from the solenoids.

NOTE!

Note position of the cables to facilitate remounting.

6. Remove the bolts and lift down the gear selector valve.

Weight, gear selector valve: **approx. 13 kg (29 lbs)**

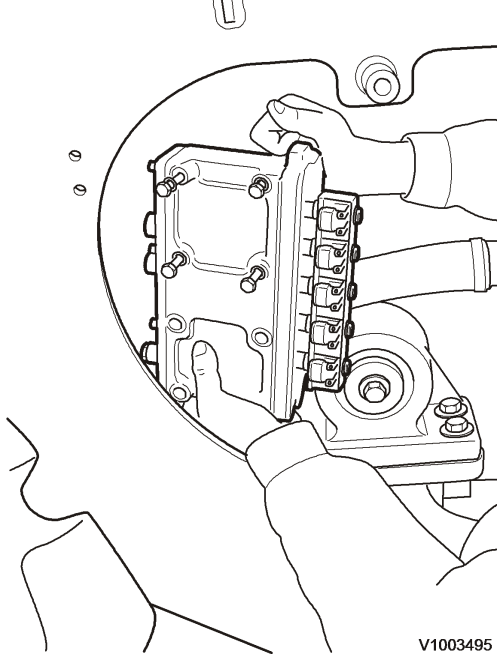

Figure 3

Mounting

7. Change gasket and fit the gear selector valve.

Weight, gear selector valve: **13 kg (29 lbs)**

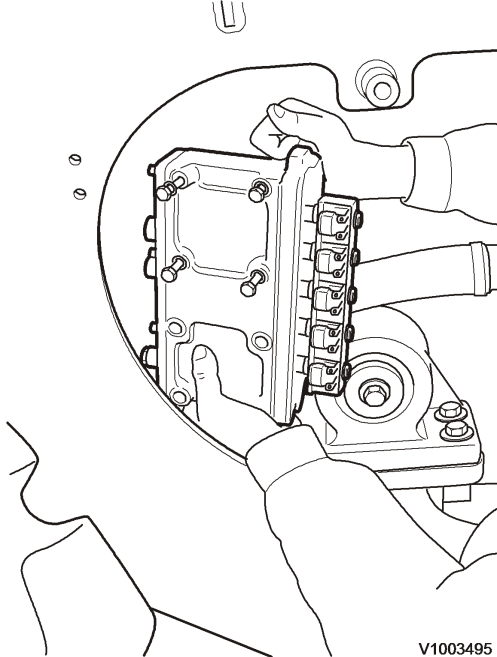

Figure 4

8. Fit the clamp in the frame for the large cable harness behind the gear selector valve.

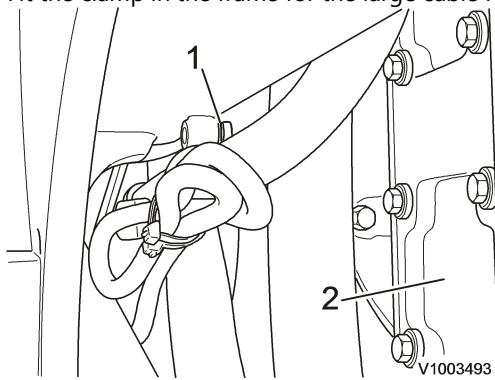

Figure 5

1. Clamp
2. Gear selector valve

9. Fit the cables and the cover on the gear selector valve.
10. Fit the valve block with MA912 and MA913 (optional equipment).
11. Fit the tool box and the steps (ladder).
Weight: **approx. 55 kg (121 lbs)**
12. Fit the front part of the rear fender.
Weight, rear fender: **25 kg (55 lbs)**
13. Check function.

Document Title: Gear selector valve, measuring resistance of solenoids	Function Group: 421	Information Type: Service Information	Date: 2014/3/27
Profile: WLO, L60E [GB]			

Gear selector valve, measuring resistance of solenoids

Op nbr 42151

[11666140 Multimeter](#)

The check is normally only performed if the error code "ERROR transmission solenoids" has been generated.

Park the machine in service position.

1. Remove the cover over the solenoids on the gear selector valve.
2. Remove the electrical cabling and connect 11666140 to a solenoid.

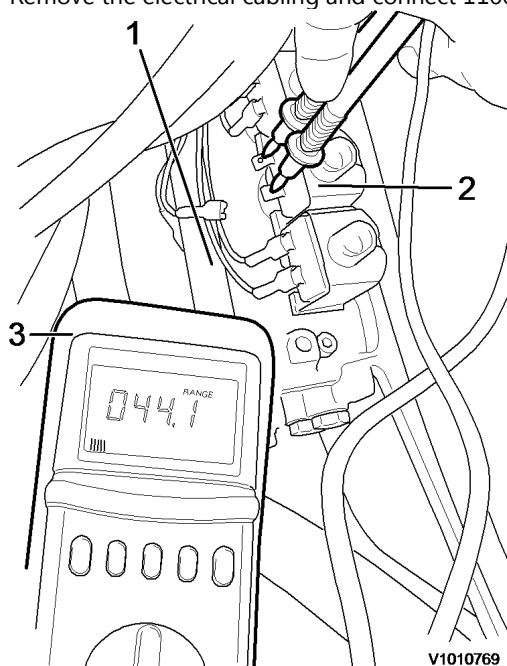

Figure 1

1. Gear selector valve
 2. Solenoid
 3. 11666140
3. Read off the resistance.
Correct resistance: **45 ±10Ω**
 4. If the solenoid is defective, continue troubleshooting in section: [301 Gearshifting solenoids](#)

NOTE!

Make sure that the cabling is not jammed in the cover and that the rubber seal's groove is fitted correctly in the cover when remounting.

Document Title: Transmission, removing	Function Group: 421	Information Type: Service Information	Date: 2014/3/27
Profile: WLO, L60E [GB]			

Transmission, removing

Op nbr 42170

[9998547 Lifting tool](#)

Part no. 939651 Nipple

Preparations

- Park the machine in service position.
- Remove the front part of the rear fenders and plates on the side of the hydraulic tank.
Weight, front part of rear fender: **25 kg (55 lbs)**
- Drain the hydraulic oil, see [173 Maintenance service, every 4000 hours](#)
- Drain the transmission oil, see [172 Warranty inspection 1000 hours](#)
- Remove the cab, see [810 Cab, removing](#)
- Depressurize the brake system by pressing down the brake pedal 30–40 times.

1. Remove the hydraulic oil tank.
Weight, hydraulic tank: **approx. 97 kg (214 lbs)**

NOTE!

Mark up the hose connections before dismantling to facilitate installation.

Advice! Lift the hydraulic oil tank approx. 40 mm (1.57 in) for easier access to hose connections.
Plug the connections.

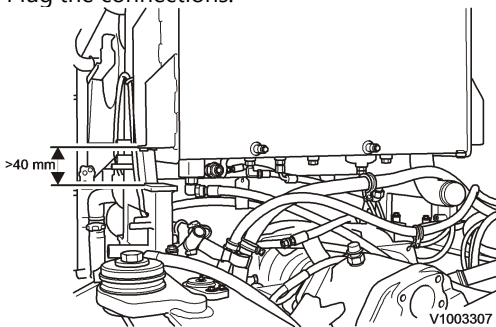
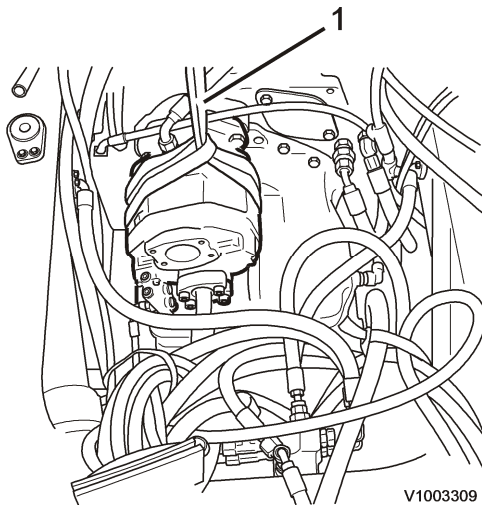

Figure 1

2. Remove connectors TA and TB through the plate with cabling from the cab and V—ECU.
3. Disconnect the hose connections for the hydraulic oil pump and remove the pump.
Weight, hydraulic pump: **approx. 55 kg (120 lbs)**
Plug the connections.



V1003309

Figure 2

4. Remove the flywheel housing's leak-oil hose from the transmission.

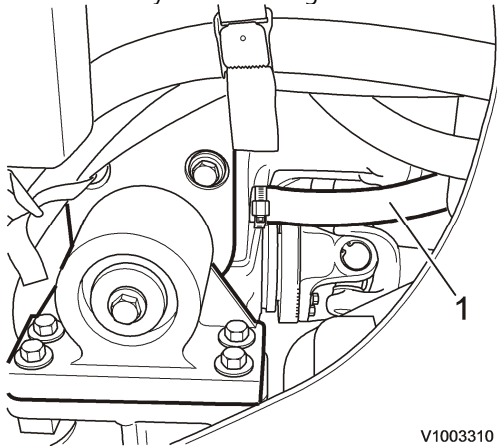

V1003310

Figure 3

1. Leak-oil hose

5. Remove the rear hydraulic hose between the left steering cylinder and the return block. Disconnect the front left steering cylinder hose from the return block. Disconnect the rear steering cylinder hose from the right steering cylinder and fold it aside. Plug the connections.

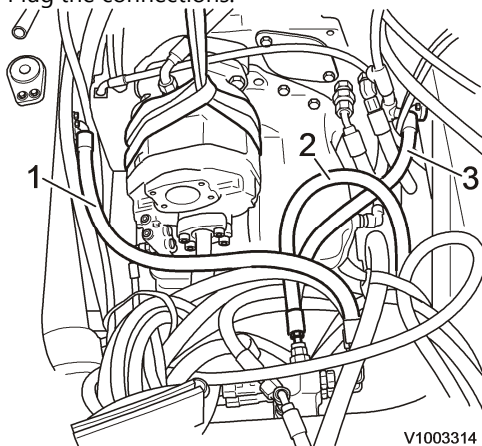

V1003314

Figure 4

1. Right rear steering cylinder hose
2. Left front steering cylinder hose
3. Left rear steering cylinder hose

6. Remove the oil filler pipe from the transmission and disconnect the breather hose from the pipe. Plug the connections.

7. Remove the breather hose and the hoses from the transmission oil cooler and plug the connections.

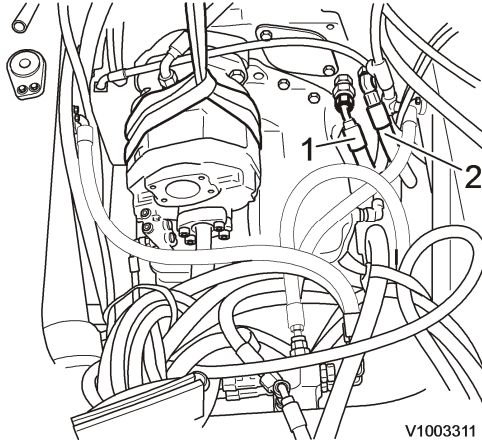

V1003311

Figure 5

1. Hose connection, transmission oil cooler
2. Hose connection, transmission oil cooler

8. Remove the rear propeller shaft.

Weight: **17 kg (37.5 lbs)**

Disconnect the front propeller shaft from the transmission and move it aside.

9. Remove the hydraulic oil hose from the parking brake caliper and plug the connection with nipple 939651.

10. Connect lifting tool 9998547 and 2 shackles in the attaching eyes on the transmission.

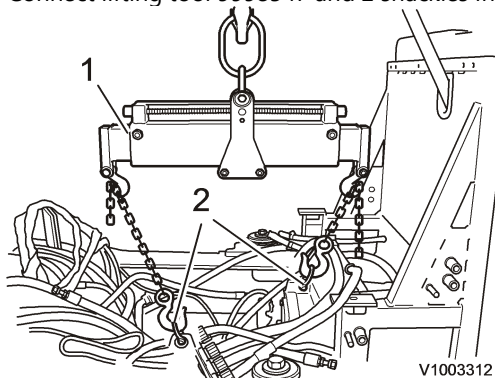

V1003312

Figure 6

1. 9998547
2. Shackle , 2 pcs.

11. Remove the bolts (1) for the transmission mounts against the frame on both sides.

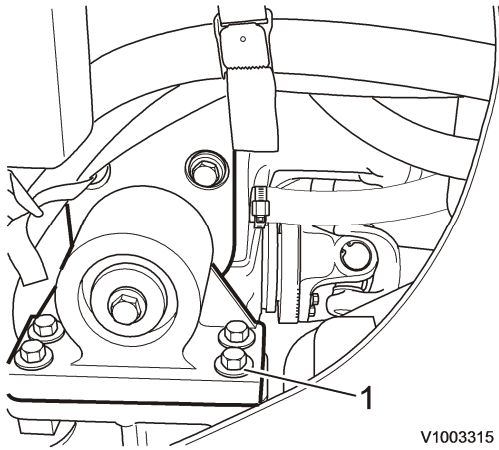

Figure 7

1. Bolts, 4 pcs.
12. Lift up the transmission and support approx. 40 mm (1.57 in) under the engine's flywheel housing with a suitable spacer.

NOTE!

Carefully lower the engine and transmission on the support and make sure that the lifting device is tight.

13. Remove the transmission mounts on both sides.
14. Remove the bolts between the engine and transmission.
15. Pull out the transmission from the flywheel housing, lower the transmission's rear edge as much as possible, lift up and turn the transmission as shown in the figure.

Weight: **approx. 450 kg (995 lbs)**

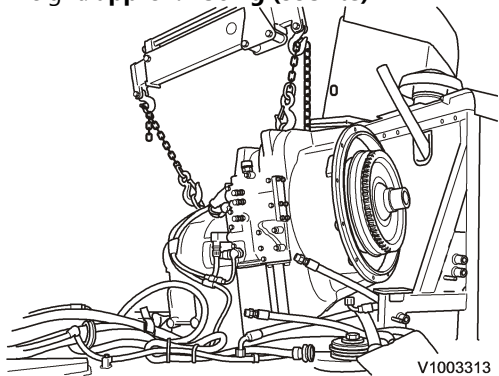

Figure 8

Document Title: Transmission, installing	Function Group: 421	Information Type: Service Information	Date: 2014/3/27
Profile: WLO, L60E [GB]			

Transmission, installing

Op nbr 42172

[9998547 Lifting tool](#)

[9998676 Rotation tool](#)

1. Check and, if needed, change the O—ring on the transmission housing. Lube the O—ring with oil before installing on the transmission.
2. Lower the transmission's rear edge as much as possible and turn down the transmission.

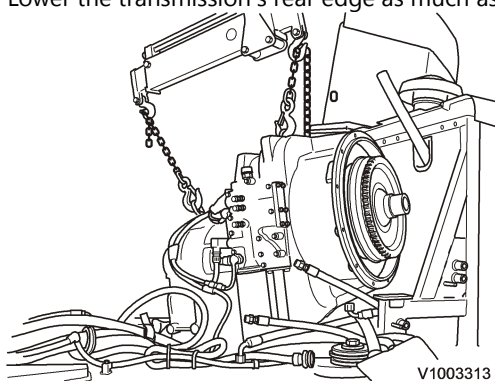

Figure 1

3. Fit the transmission against the flywheel housing.
Keep the lifting device tight.
Fit and tighten the bolts between the transmission and engine.
Tightening torque: **60 Nm (45 lbf ft)**

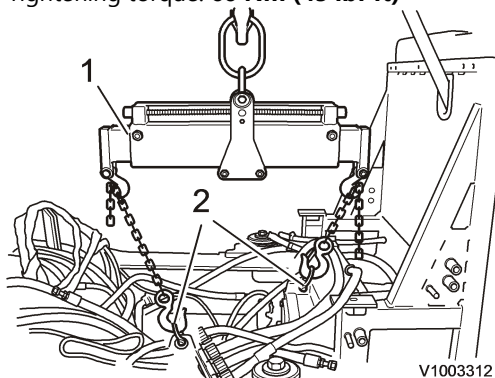

Figure 2

1. 9998547
2. Shackle , 2 pcs.

4. Fit the transmission mounts on the transmission.

Tightening torque: **220 Nm (162 lbf ft)**

5. Lift up the transmission and remove the support under the flywheel housing.
6. Lower the transmission and tighten down the transmission mounts against the frame.
Tightening torque: **220 Nm (162 lbf ft)**

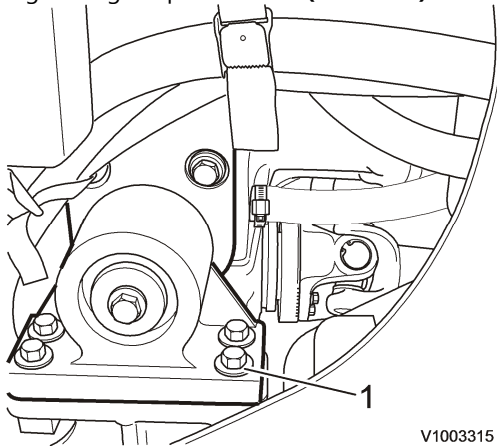

Figure 3

1. Bolts, 4 pcs.
7. Fit the propeller shafts.
Weight, rear propeller shaft: **17 kg (37.5 lbs)**
Tightening torque propeller shaft: **115 Nm (85 lbf ft)**
8. Fit the hydraulic hose for the parking brake.
9. Fit the flywheel housing's leak-oil hose.

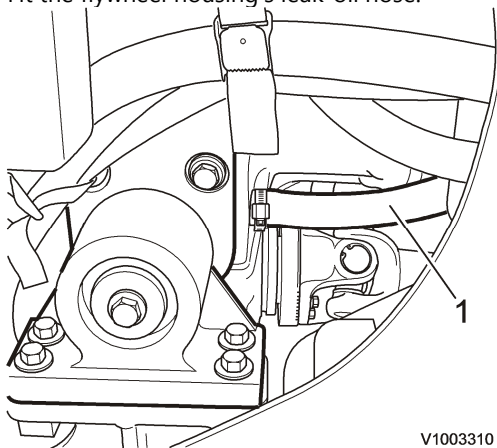

Figure 4

1. Leak-oil hose
10. Fit the transmission oil filler pipe and its breather hose.
11. Check and, if needed, change the O—ring on the hydraulic pump. Lube the seal ring with oil before installing.
12. Fit the hydraulic pump including hoses.
If needed, rotate the engine crankshaft with 9998676.
Weight, hydraulic pump: **55 kg (120 lbs)**

Thank you very much for reading.

This is part of the demo page.

GET MORE:

Hydraulic

System, Setting

Instructions, Functional

Description, Electrical

System And more.....

Click Here BUY NOW

Then Instant Download

the Complete Manual.

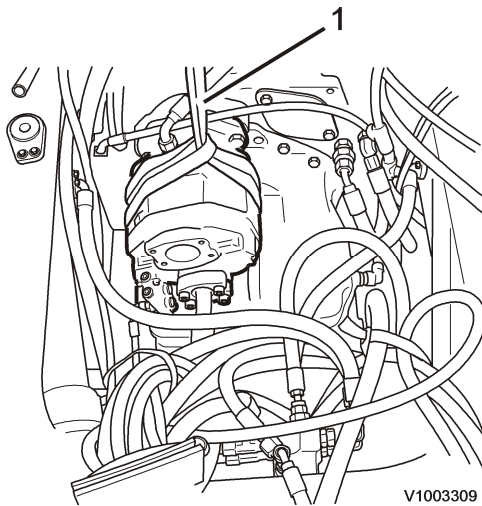

Figure 5
V1003309

13. Fit the hydraulic hoses for the steering cylinders, and the hydraulic hoses from the transmission oil cooler.

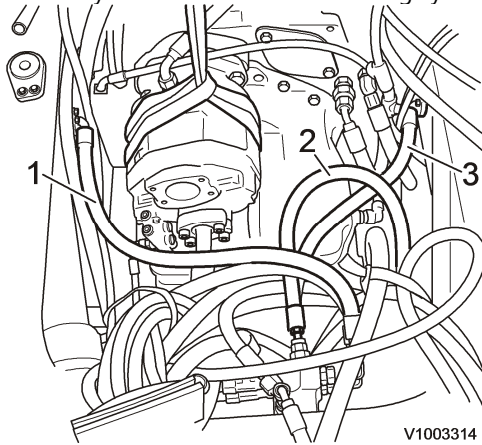

Figure 6

1. Right rear steering cylinder hose
2. Left front steering cylinder hose
3. Left rear steering cylinder hose

14. Fit the hydraulic oil tank and connected the disconnected hydraulic hoses as well as SE906.
Weight, hydraulic tank: **approx. 97 kg (214 lbs)**
Advice! Leave the tank raised approx. 40 mm (1.57 in) for easier access when installing hydraulic hoses.



Figure 7

15. Insert connectors TA and TB through the hole in the plate for connectors in the cab wall.

16. Fit the cab, see [810 Cab, installing](#).
17. Fill transmission and hydraulic oil, see [172 Warranty inspection 1000 hours](#) and [173 Maintenance service, every 4000 hours](#).
18. Fit the plates on the sides and over the hydraulic tank as well as the front part of the rear fenders.
Weight, front part of rear fender: **25 kg (55 lbs)**
19. Bleed the hydraulic system according to [900 Hydraulic system, bleeding](#).
20. Test-run and check for leaks, top up with hydraulic oil and transmission oil if needed.