

Document Title: Description	Function Group: 400	Information Type: Service Information	Date: 2014/3/27
Profile: WLO, L50E [GB]			

Description

The drive line receives its power from a 4-cylinder diesel engine. The diesel engine drives a hydraulic pack consisting of four hydraulic pumps, 1, 2, 3 and 4. The pump nearest to the diesel engine, that is the hydrostatic pump (in this manual also called the HS-pump) transfers the power via hydraulic hoses with pressurised oil to the hydrostatic motor, 6 (in this manual also called the HS-motor). The oil pressure in the system is over 40 MPa (400 bar) (5802 psi).

The hydrostatic motor output shaft drives a dual range gearbox, 1. The gearbox drives the front and rear axles via propeller shafts. The gear pump, 2, provides the gearbox clutch shafts with lubricating oil pressure and clutch pressure.

Working principle of the hydrostatic drive

With increasing rolling resistance, e.g. when operating uphill or when filling the bucket, the hydrostatic system naturally has to work harder to turn the drive shafts and the wheels via the gearbox.

This causes the counter pressure in the hose between the pressure side of the HS-pump and the HS-motor to rise. The reaction to this increase in pressure is that the hydrostatic motor, which has a variable displacement, automatically increases its displacement, i.e. the HS-motor needs a greater flow to maintain the same speed. As the HS-pump flow does not change, the speed of the HS-motor drops and this causes the torque to increase. In this way an automatic "downshifting" is achieved.

If the torque even so is not sufficient, the back-pressure in the hose increases further. At a certain level of back-pressure the HS-pump automatically reduces its displacement. In this way the pump pressure and thereby the torque can be maintained.

When the flow drops, the power output of the diesel engine reduces, which allows the diesel engine to run at the speed range which is most favourable as regards fuel consumption.

The power transmission, which is more efficient, allows a large proportion of the engine output to be utilised by the hydraulic pumps 2 and 3, which supply oil to the brake and cooling fan system as well as the steering, servo and working hydraulics systems.

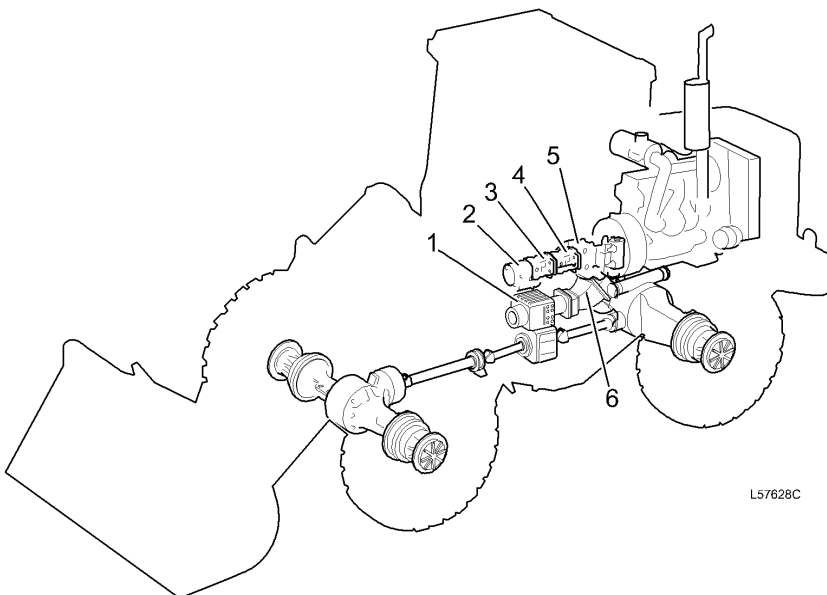

L57628C

Figure 1
Hydrostatic power transmission (position of components)

1. Gearbox HST-75
2. Pump for gearbox

3. Hydraulic pump for brake and fan systems
4. Hydraulic oil pump, for brake, steering and servo systems and working hydraulics
5. Hydrostatic pump
6. Hydrostatic motor

Advantages with hydrostatic power transmission

- The output from the diesel engine is more efficiently distributed between the drive line and the working hydraulics.
- The entire diesel engine output can be used for accelerating and for achieving a higher propulsion speed when driving uphill.
- The gearbox has only two mechanical ranges, high and low, where each mechanical range includes two hydraulic ranges in the HS-motor.
- With the max. displacement lock in the HS-motor engaged, the machine has very good off-road properties which allows the machine to "climb" over obstacles at a controlled speed.
- Very good hydrostatic engine retarding properties which reduces the wear on the ordinary brake system.
- When stalled, the hydrostatic power transmission uses little power, which means that there is always a surplus of engine power for the working hydraulics.
- Low fuel consumption and low sound level.

Hydrostatic pump (HS-pump)

The HS-pump is a nine-cylinder axial piston pump with a variable displacement. Yoke 1 is moveable and can be angled $\pm 15^\circ$ on either side of the neutral position. Yoke 1 is mechanically actuated by a lever 2 which is connected to control piston 6.

The angle of the yoke determines the stroke of pistons 3. If the angle is increased, the stroke of the pistons will increase. When the yoke is in neutral position, the stroke is zero and consequently the displacement is zero.

If the yoke is angled from one side of the neutral position over to the other, the direction of the oil flow changes. This means that the machine can be operated both forward and rearward while the HS-pump rotates in the same direction.

The forward and rearward drive is operated electrically via the gear selector control. Signals are transmitted through the solenoid valves on the directional valve 5, which controls the oil pressure on control piston 6, which in turn can angle the yoke to a negative or a positive angle.

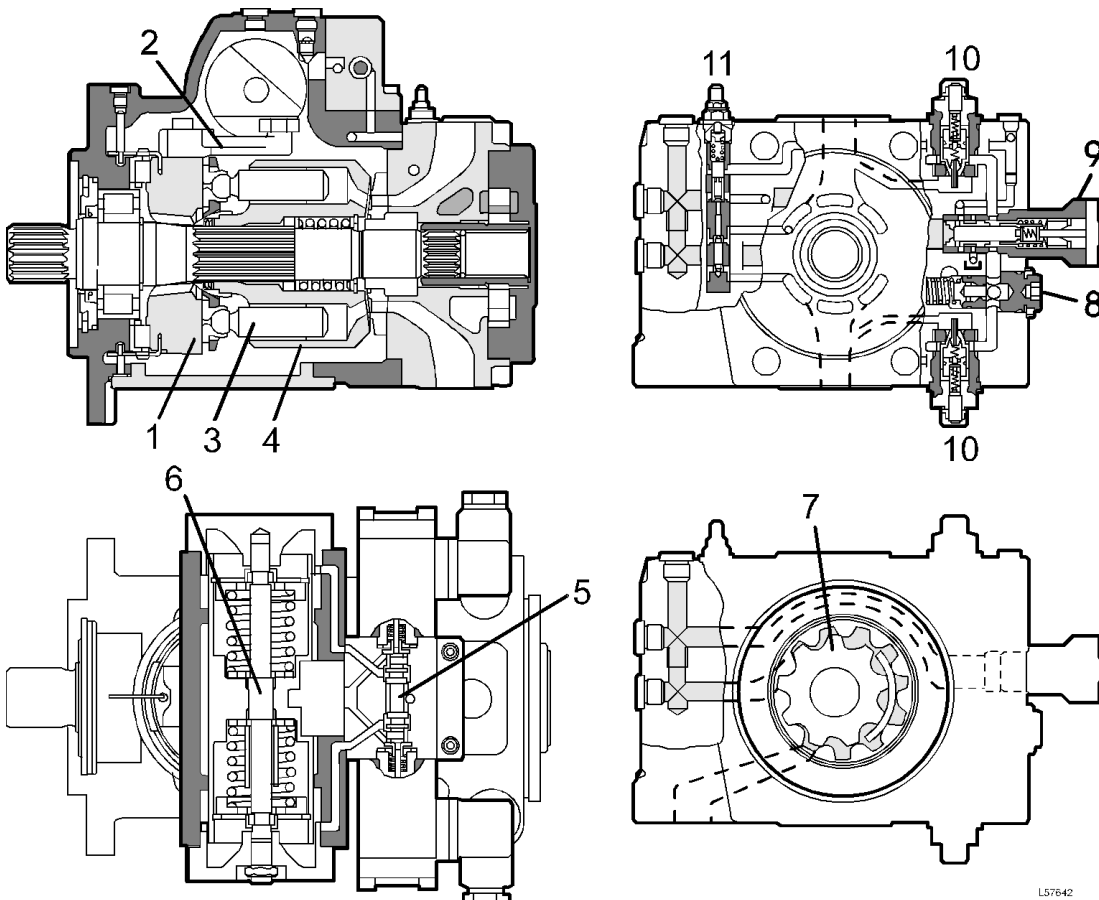

L57642

Figure 2

Hydrostatic pump

1. Yoke
2. Lever
3. Piston
4. Piston drum
5. Directional valve, electrically controlled via MA409 or MA410
6. Control piston
7. Charge pump
8. Charge-pressure valve
9. Control valve
10. Shock valves with non-return valve function
11. Pressure cut-off valve

Pump circuit components

- 1 HS-pump **axial piston unit**.
- 2 **Charge pump** sucks oil from the hydraulic tank, which also serves the rest of the hydraulic system. The charge pump makes sure that there is always oil available at charge pressure by control valve 8 and the axial piston unit 1.
The charge pressure passes through **filter 3** which has a **differential pressure sensor 4** which warns if the pressure drop across the filter becomes too great. When the filter is clogged, **safety valve 6** opens and the machine cannot be operated.
When starting in very cold weather, it may take a few minutes before the machine can be operated as the oil is viscous and must be warmed up before safety valve 6 closes. **Sensor 5** warns if the charge pressure is too low ($<1.5 \pm 0.2$ MPa (15 ± 2 bar) (218 ± 73 psi)).
- 7 **Charge-pressure valve**. Limits the charge pressure to the high-pressure circuit and directs the remaining flow via the pump housing to the HS-motor in order to dissipate heat from the HS-pump and to lubricate and add to the flow of cooling oil in the HS-motor.
- 8 **Control valve**, pressure/flow-controlled. Uses part of the flow from charge pump 2 and directs it at a control pressure proportional to the diesel engine speed via the electrically controlled **directional valve 9** to **control piston 10**. The control pressure is also conducted to the brake defeat valve (19) on the HS-motor and locks the same.
- 11 **The pressure cut-off valve** limits the maximum pressure from the HS-pump, by draining the control pressure from control piston 10 to the pump housing, thus reducing the displacement. The HS-pump maintains the maximum pressure, but reduces the displacement which means that less torque is required from the diesel engine in spite of full pressure.
This means that the machine, when stalled, has full pulling power at the same time as the diesel engine is not loaded.
The shuttle valve selects the highest pressure regardless of whether the machine is operated forward or rearward.
- 12 **Shock valves** with non-return valve functions. One for operating forward and one for operating rearward. The valves conduct high-pressure to the low-pressure side if pressure shocks arise and if the pressure cut-off valve 11, due to the dampening of the pump, is not quick enough in reducing the displacement.
- 13 **Excess pressure valve**, opens if the pressure in the pump housing exceeds approx. 2 bar (29 psi) in order to protect the seals against overloading.
This happens when starting a cold machine when the oil is viscous.

Hydraulic diagram, hydrostatic drive

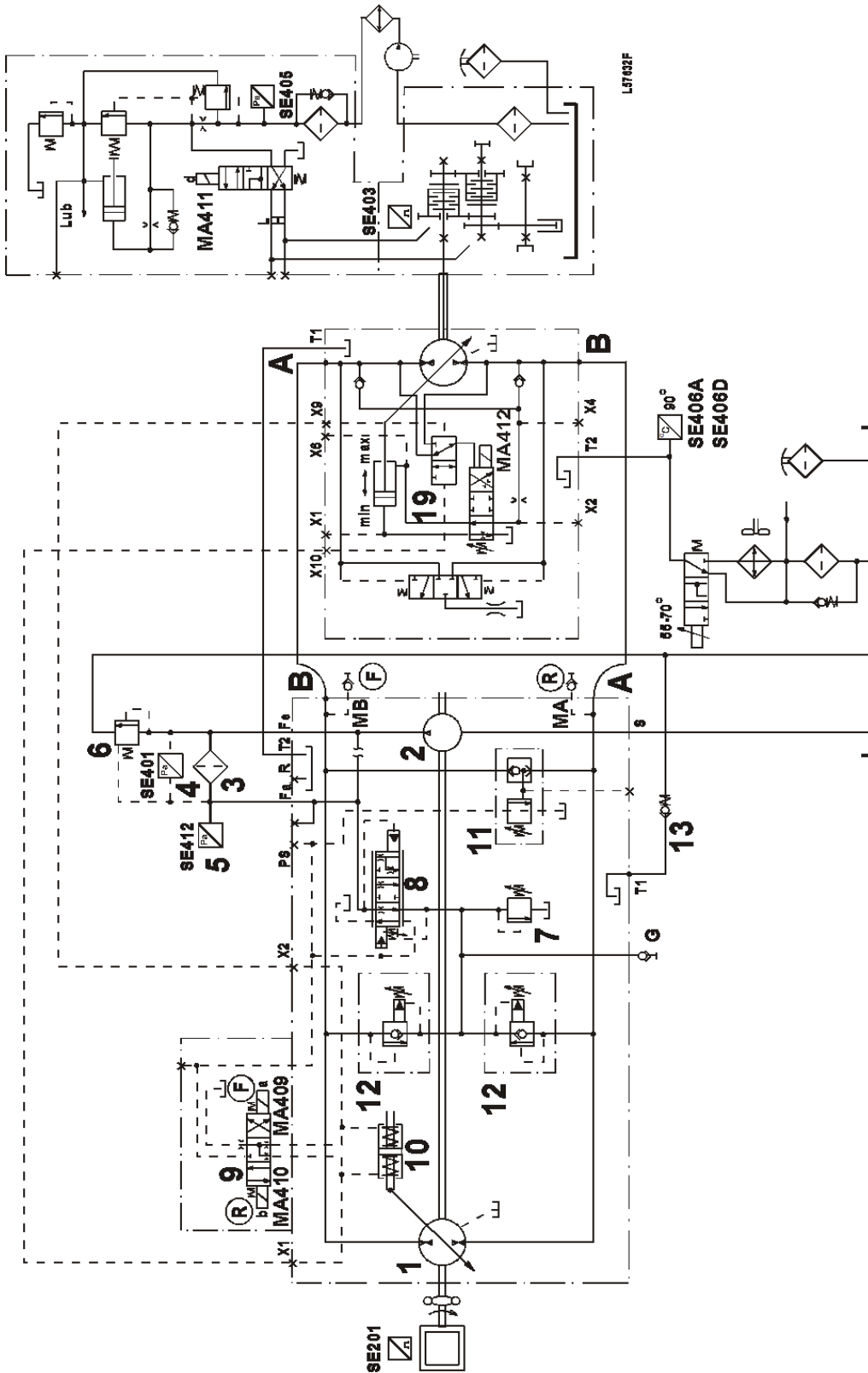

Figure 3

Hydrostatic motor (HS-motor)

The HS-motor is a nine-cylinder axial piston unit with variable displacement according to the "Bent Axis" principle. It can operate either as a pump or as a motor in a hydraulic system. On the L50D it is used as a motor.

The HS-motor is supplied with oil from the HS-pump. Through high pressure and displacement a conversion to a torque takes place. The magnitude of the output torque depends on the displacement and the pressure in the HS-motor.

Min. displacement means that a small amount of oil is required to turn the HS-motor one revolution.

Max. displacement means that the HS-motor "changes" down and requires a large amount of oil to turn the HS-motor one revolution, i.e. the pulling power of the machine increases.

The initial position of the HS-motor is normally always minimum displacement.

The displacement valve 3 is controlled by the high pressure from the HS-pump. When the pressure exceeds 26.5 MPa (265 bar) (3843.5 psi), e.g. when the bucket is forced into a gravel bank in order to fill the bucket, the displacement valve 3 opens and the oil pressure actuates control piston 4. The movement of the control piston is transferred mechanically through a pin to the axial piston unit 1 and the displacement increases to maximum.

During, for instance, off-road operation, one can lock the pump in the max. displacement position by actuating solenoid valve MA412 on the displacement valve 3 with switch SW411. This means that the machine can "climb" over obstacles at a controlled speed.

It is also possible temporarily to lock the HS-motor in the max. displacement position when an increased hydrostatic motor retarding effect is required. This is done by activating the spring-return switch SW406 on the control lever carrier.

NOTE!

Temporary max. displacement locking should be used with caution until the operator has become familiar with the braking (retarding) properties.

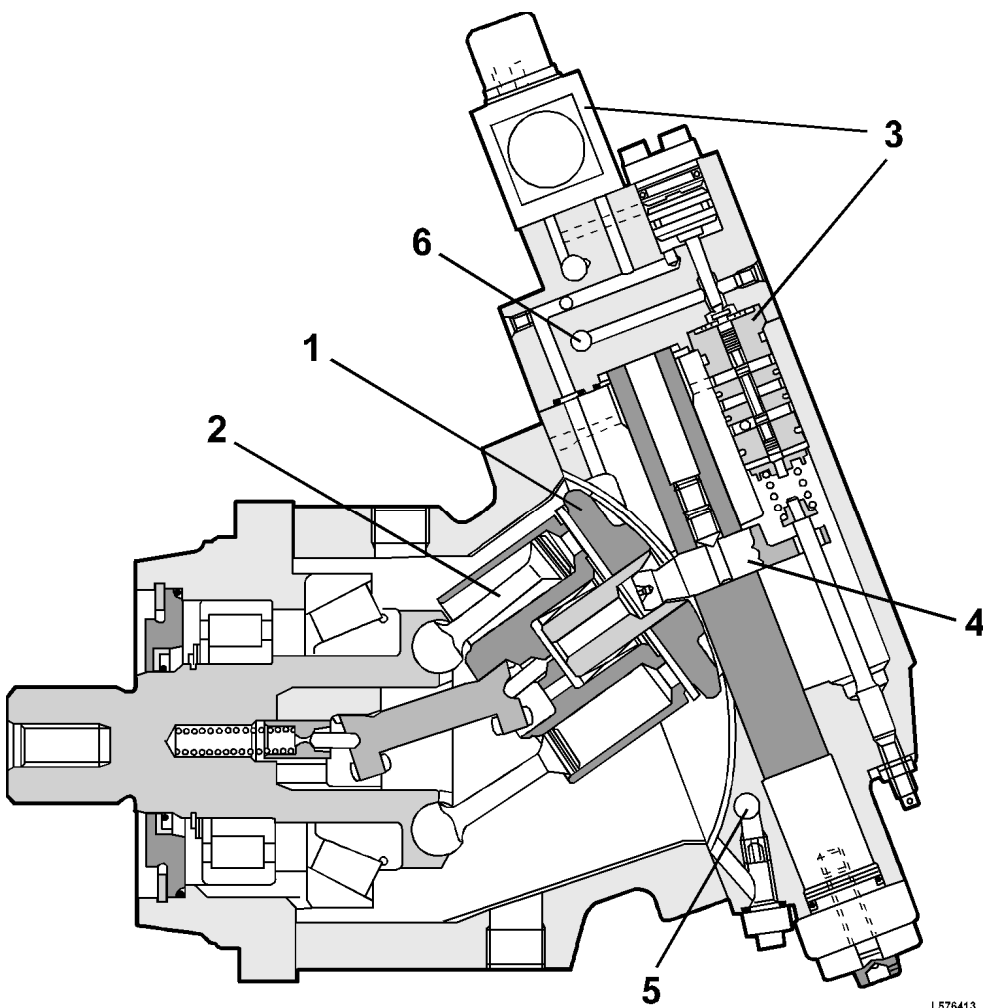

Figure 4
Hydrostatic motor (max. displacement)

1. Movable axial piston unit
2. Piston with piston rings
3. Displacement valve with electrically controlled max. displacement locking via MA412
4. Control piston with pin
5. Flushing valve
6. Brake defeat valve

Hydrostatic motor component parts

- 15 HS-motor **axial piston unit**.
- 16 **Non-return valves**. Admits oil from the high-pressure side to the displacement valve 17. The high-pressure side and the low-pressure side change when changing travelling direction. On the low-pressure side there is always oil at charge pressure supplied by the charge pump 2 of the HS-pump.
- 17 **Displacement valve**. Controlled by the high pressure from the HS-pump the displacement valve is used for changing from minimum to maximum displacement. Maximum displacement can also be obtained via solenoid valve MA412.
- 18 **Control piston**. Controlled by pressure via the displacement valve 17. It changes the displacement mechanically through a pin which actuates the moveable axial piston unit 15.
- 19 **Brake defeat valve**. Prevents an uncontrollable change of the displacement from minimum to maximum when operating down steep hills, as this would mean a risk of overspeeding the diesel engine. The brake defeat valve is actuated by the control pressure from directional valve 9 on the HS-pump.
- 20 **Flushing valve**. A high-pressure controlled spool which uses oil which has circulated in the high-pressure circuit. After the oil has passed the HS-motor it moves on to the flushing valve in order to dissipate heat from the HS-pump and to cool and lubricate the HS-motor.
The oil flows from the HS-motor housing to thermostat 21 and, depending on the temperature of the oil, continues directly to the tank or through the oil cooler 22 installed by the engine radiator or alternatively to both. The temperature sensor 23 (SE406) warns of high oil temperature.

Gearbox HST-75, component parts

- 24 **Gear pump**. Supplies the gearbox with clutch pressure and lubricating oil pressure. The oil is drawn from the sump of the gearbox. The pump is mounted in tandem with the pump for steering, brake, servo and working hydraulics as well as the HS-pump 1.
- 25 **Suction strainer**. Cleaned in connection with changing oil in the gearbox.
- 26 **Oil filter**.
- 27 **Sensor, SE405**. Warns of low clutch pressure, $<1.5 \pm 0.2$ MPa (15 ± 2 bar) (218 ± 29 psi)
- 28 **Flow-limiting valve**.
- 29 **Gear selector valve MA411**. High/Low gear.
- 30 **Pressure-control valve for clutch pressure**. Consists of a modulator piston and a pressure-limiting valve, ≤ 2.15 MPa (21.5 bar) (312 psi).
- 31 **Lubricating-oil pressure valve**. 0.03–0.05 MPa (0.3—0.5 bar) (4.4—7.3 psi)
- 32 **Low gear clutch**.
- 33 **High-gear clutch**.
- 34 **Breather filter**.

Hydraulic diagram, hydrostatic drive

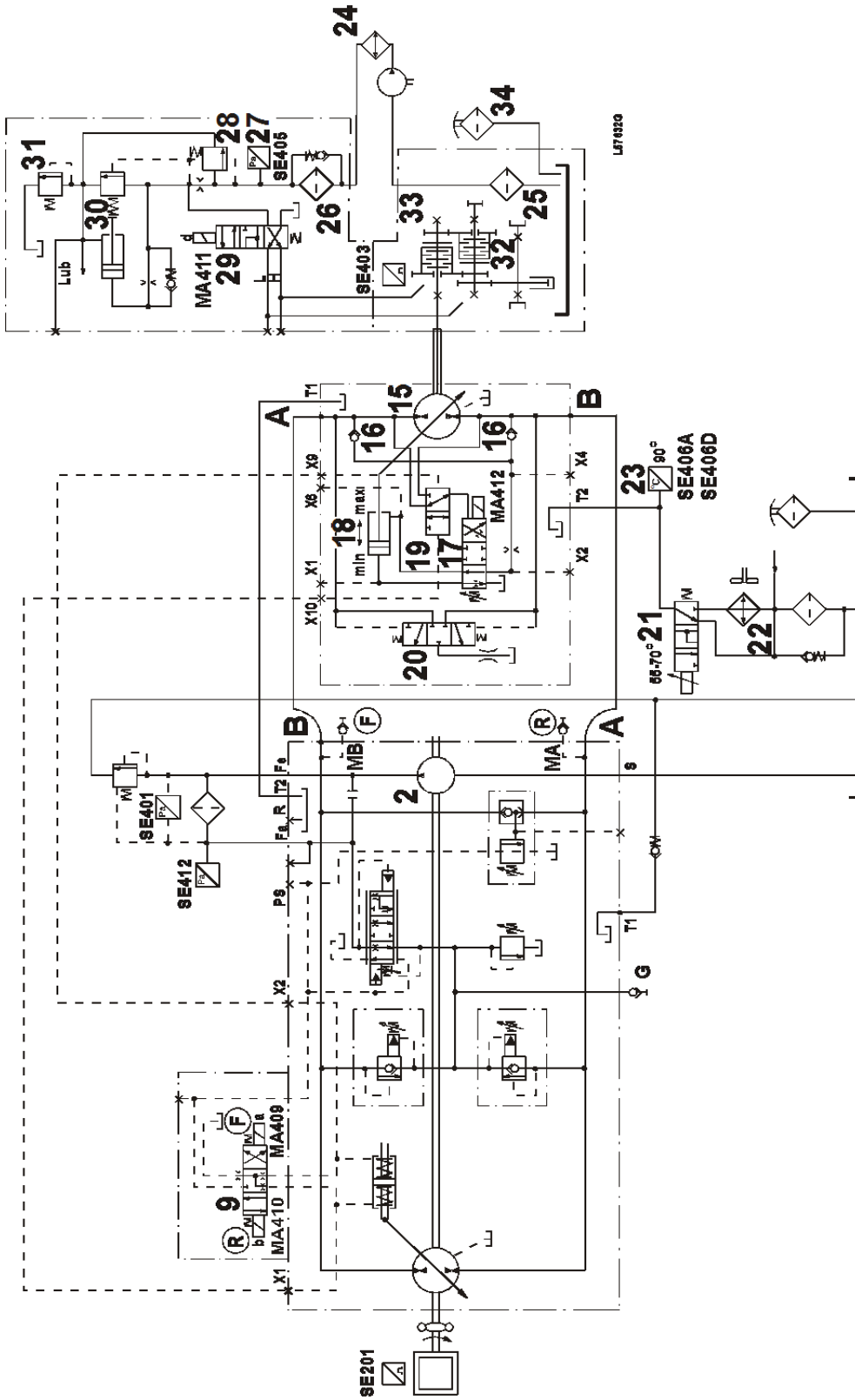

Figure 5
Hydraulic diagram, hydrostatic drive

Document Title: Gearbox, removing	Function Group: 421	Information Type: Service Information	Date: 2014/3/27
Profile: WLO, L50E [GB]			

Gearbox, removing

Op nbr 43474

Lifting eye M16

1. Place the machine in Service Position, see [191 Safety rules when servicing](#).
2. Drain the gearbox oil.
3. Remove the operator seat. The seat weighs **45 kg (100 lb)**



Figure 1
Lifting out seat

4. Remove the floor mat and the floor plates.
5. Remove the rear propeller shaft.

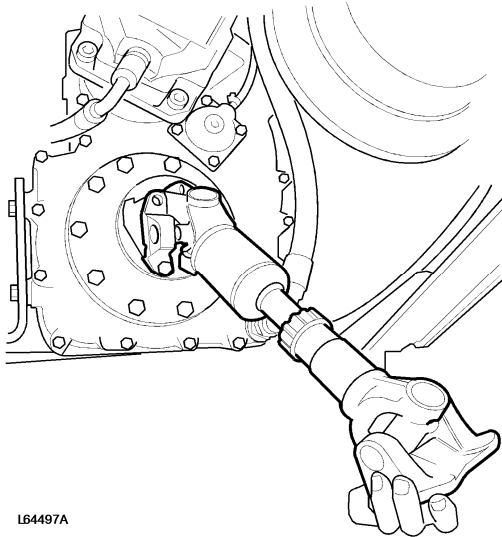

Figure 2
Removing rear propeller shaft

6. Detach the front propeller shaft from the gearbox and lay it to one side.

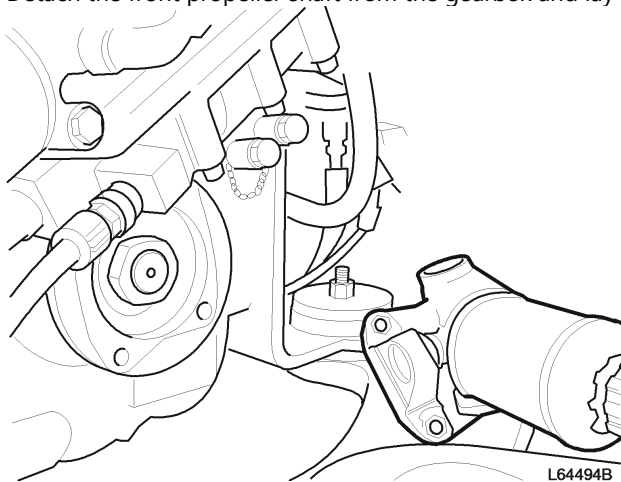

Figure 3
Front propeller shaft disconnected

7. Disconnect the hoses from the hydraulic pump of the gearbox and install plastic plugs in the openings.

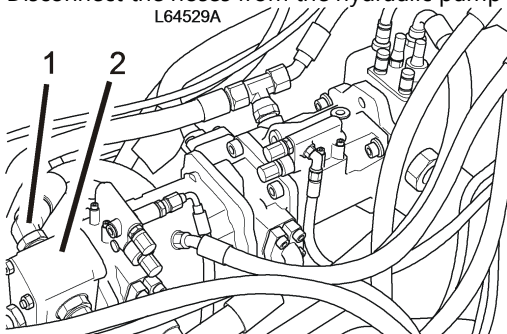

Figure 4

1. Hydraulic hoses
2. Hydraulic pump, gearbox

8. Loosen the clamp retaining the hydraulic hoses to the hydrostatic motor.

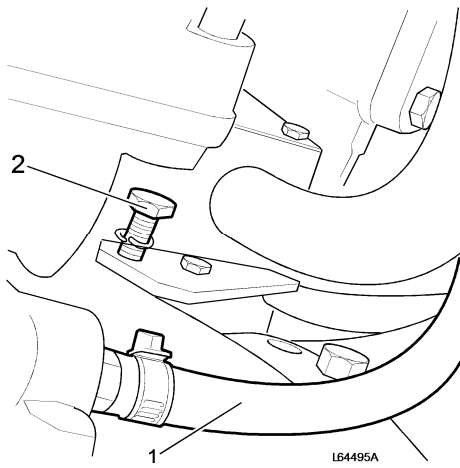

Figure 5

1. Breather hose for gearbox
2. Bolt for the clamp retaining the hydraulic hoses

9. Take apart the connector at sensor SE403.

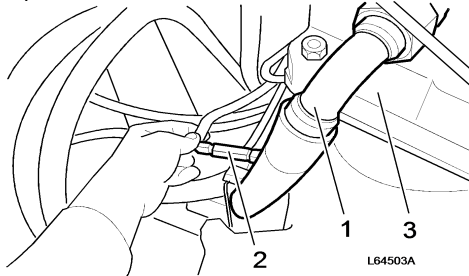

Figure 6

1. Hydraulic hose to hydrostatic motor
2. Cable connection for sensor SE 403
3. Hydrostatic motor

10. Suspend the hydrostatic motor with the aid of a ratchet block. Remove the four bolts retaining the hydrostatic motor and remove it from the gearbox.

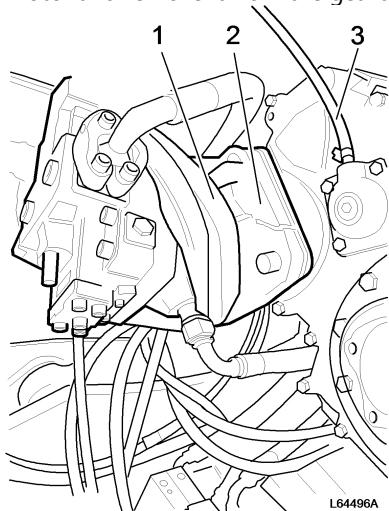

Figure 7

1. Lifting sling

2. Hydrostatic motor
3. Breather hose for gearbox

11. Remove the breather hose from the gearbox.

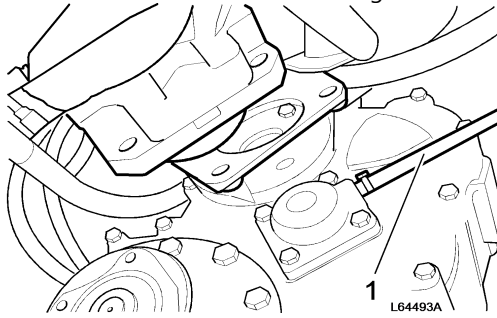

Figure 8

1. Breather hose

12. Disconnect the connectors from sensor SE405 and solenoid AM411.

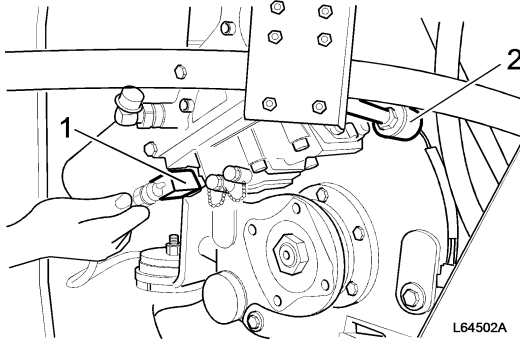

Figure 9
Removing connectors

1. Solenoid MA411
2. Sensor SE405

13. Remove the gearbox oil filter.

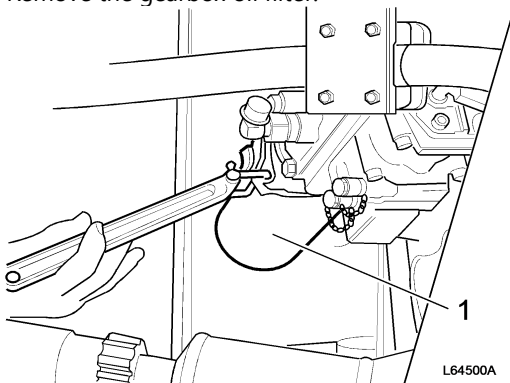

Figure 10
Removing hydraulic oil filter

1. Hydraulic oil filter

14. Detach the hydraulic hose bracket, which is secured to the gearbox.

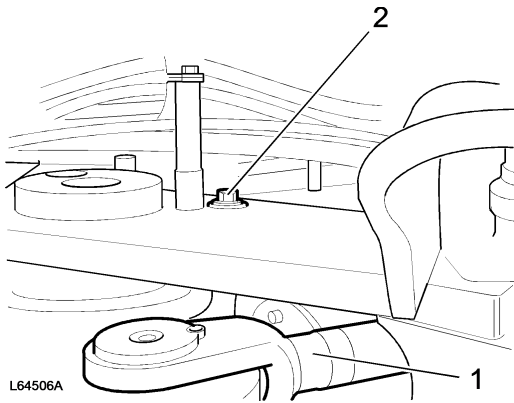

Figure 11
Front attaching bolts for hydraulic hoses

1. Piston rod, left steering cylinder
2. One out of two front attaching bolts for hydraulic hoses

15. Install a lifting eye, M16 on the gearbox.
16. Connect a sling and ratchet block over the cab roof and connect to the lifting eye.
 The weight of the gearbox is: **170 kg (375 lb)**

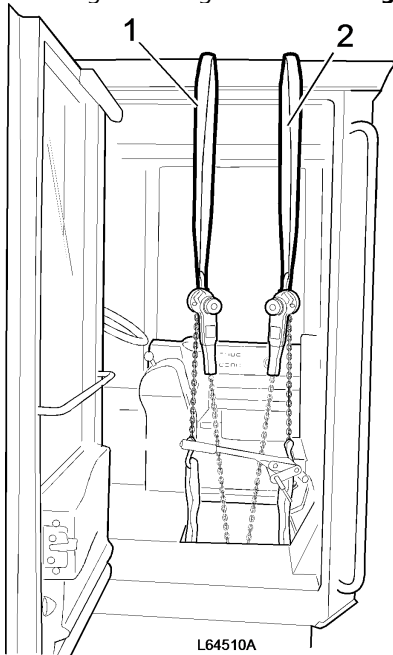

Figure 12

1. Sling and ratchet block for gearbox
2. Sling and ratchet block to keep the hydrostatic motor in position

17. Remove one of the two brackets retaining the gearbox.

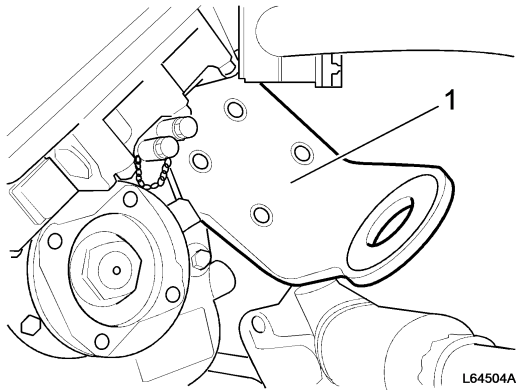

Figure 13

1. Left bracket for gearbox

18. Remove the four bolts retaining the other bracket. Leave the bracket in place in the rear frame.
19. Lower the gearbox to the ground level. Carefully check that no fragile parts, e.g. solenoid valve and sensors are damaged.

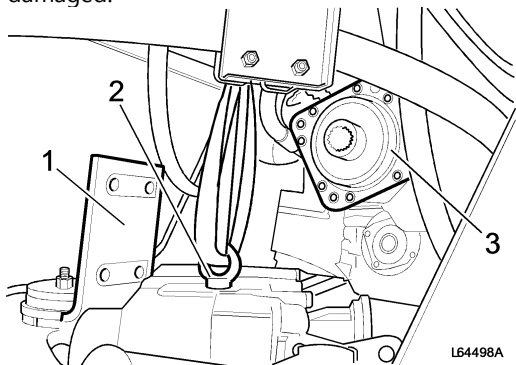

Figure 14

Gearbox lowered to the ground.

1. Right bracket for gearbox
2. Lifting eye M16
3. Hydrostatic motor, exposed and suspended

20. Lay the gearbox on its side and pull it out to one side in front of the rear wheel.

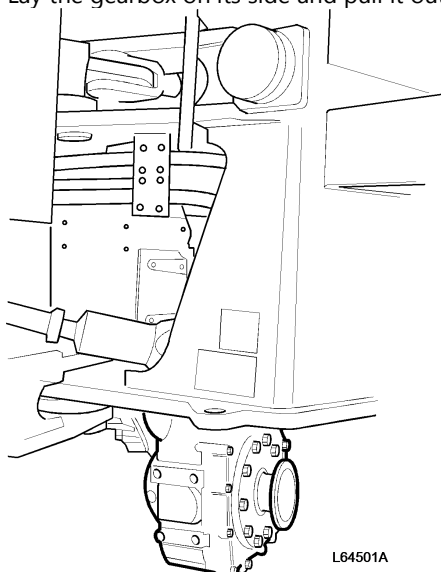

Figure 15
Gearbox on the ground.

Document Title: Gearbox, installing	Function Group: 421	Information Type: Service Information	Date: 2014/3/27
Profile: WLO, L50E [GB]			

Gearbox, installing

Op nbr 43473

Lifting eye M16

1. Move the gearbox in under the machine and connect a hoist in the same way as when removing the gearbox. The weight of the gearbox: **170 kg (375 lb)**.

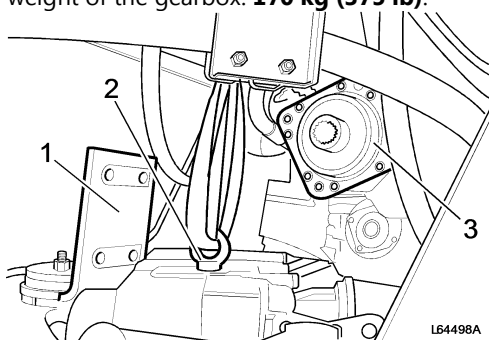

Figure 1
Gearbox lowered to the ground.

1. Right bracket for gearbox
2. Lifting eye M16
3. Hydrostatic motor, exposed and suspended

2. Lift the gearbox and install its brackets.

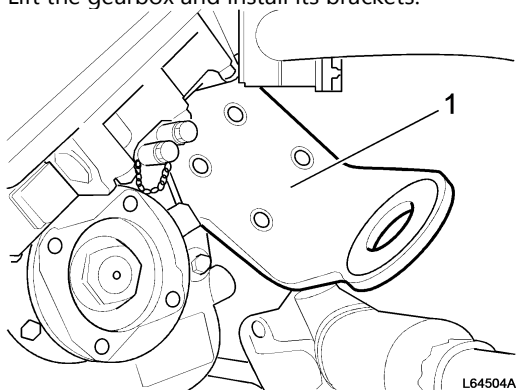

Figure 2

1. Left bracket for gearbox
3. Remove the lifting device and install the bracket for the hydraulic hoses on the gearbox.

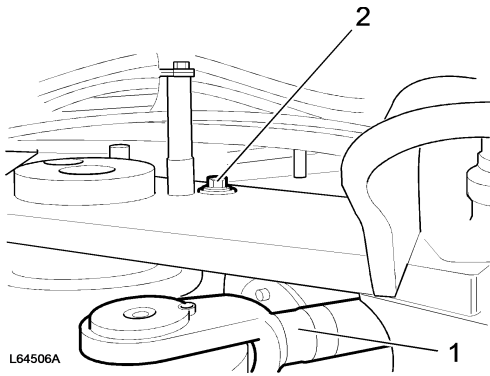

Figure 3
Front attaching bolts for hydraulic hoses

1. Piston rod, left steering cylinder
2. One out of two front attaching bolts for hydraulic hoses

4. Install the gearbox hydraulic oil filter.
5. Connect the cables to sensor SE405 and solenoid MA411.

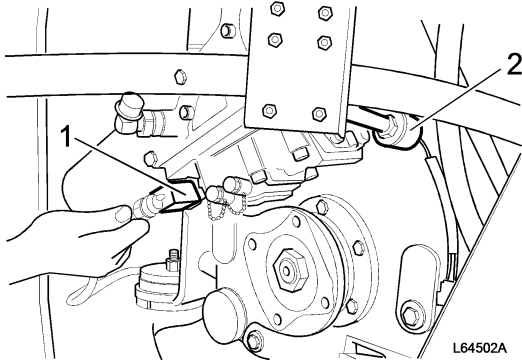

Figure 4

1. Solenoid MA411
2. Sensor SE405

6. Install the breather hose on the gearbox.

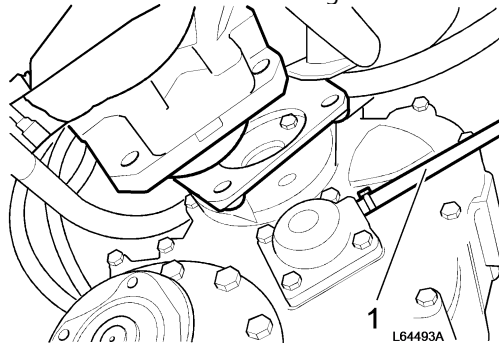

Figure 5

1. Breather hose

7. Install a new O-ring on the hydrostatic motor.

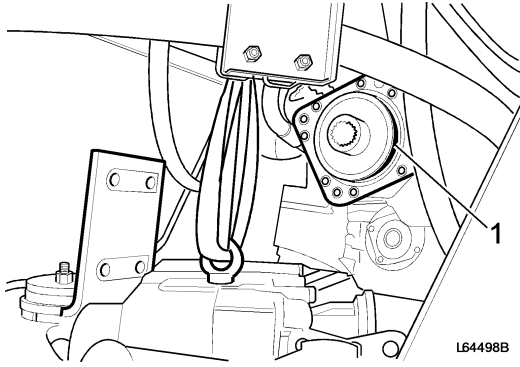

Figure 6

1. Position of O-ring
8. Install the hydrostatic motor on the gearbox. Remove the lifting device.

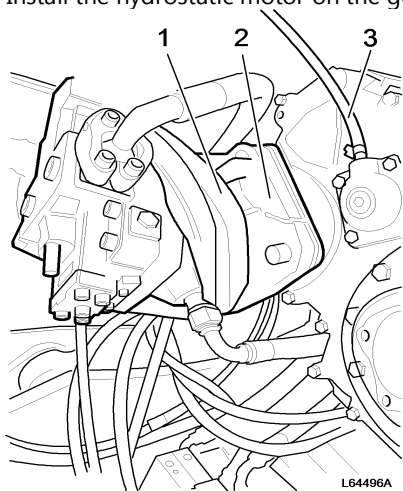

Figure 7
Installing, hydrostatic motor

1. Lifting sling
2. Hydrostatic motor
3. Breather hose for gearbox
9. Install the bracket for the hydraulic hoses on the hydrostatic motor.

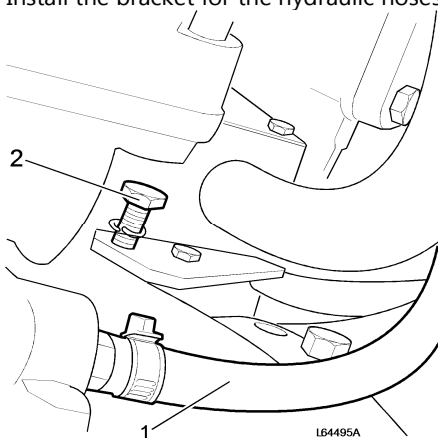

Figure 8

1. Breather hose for gearbox
2. Bolt for clamp for hydraulic hoses

Thank you very much for reading.

This is part of the demo page.

GET MORE:

Hydraulic

System, Setting

Instructions, Functional

Description, Electrical

System And more.....

Click Here BUY NOW

Then Instant Download

the Complete Manual.

10. Install the cable connection for sensor SE403.

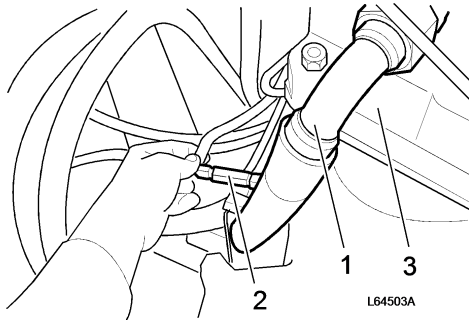

Figure 9

1. Hydraulic hose (on the left side of the machine) to hydrostatic motor
2. Cable connection for sensor SE 403
3. Hydrostatic motor

11. Install the hoses for the hydraulic pump on the gearbox.
12. Install the front propeller shaft on the gearbox. Torque-tighten the bolts.
Tightening torque: **110 Nm (81.2 lbf ft)**

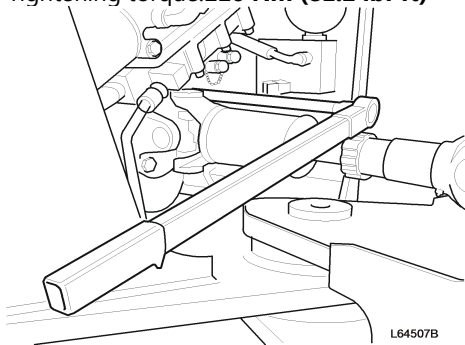

Figure 10
Torque-tightening front propeller shaft

13. Install the rear propeller shaft on the gearbox. Torque-tighten the bolts.
Tightening torque: **110 Nm (81.2 lbf ft)**

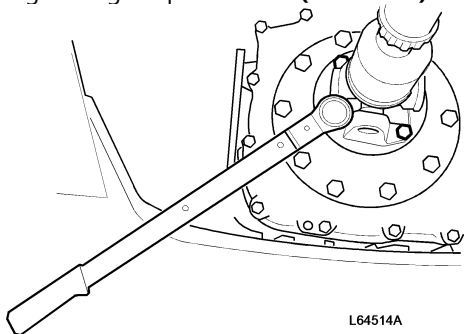

Figure 11
Torque-tightening rear propeller shaft

14. Install floor plates, floor mat and operator seat.
The seat weighs **45 kg (100 lb)**.



Figure 12
Lifting in seat

15. Fill oil in the gearbox.
16. Test-run the machine.
17. Check its functions and that there are no leaks.