

Document Title: <b>Component locations</b>	Function Group: <b>200</b>	Information Type: <b>Service Information</b>	Date: <b>2014/9/28</b>
Profile: <b>EXC, ECR235D L [GB]</b>			

**Component locations**

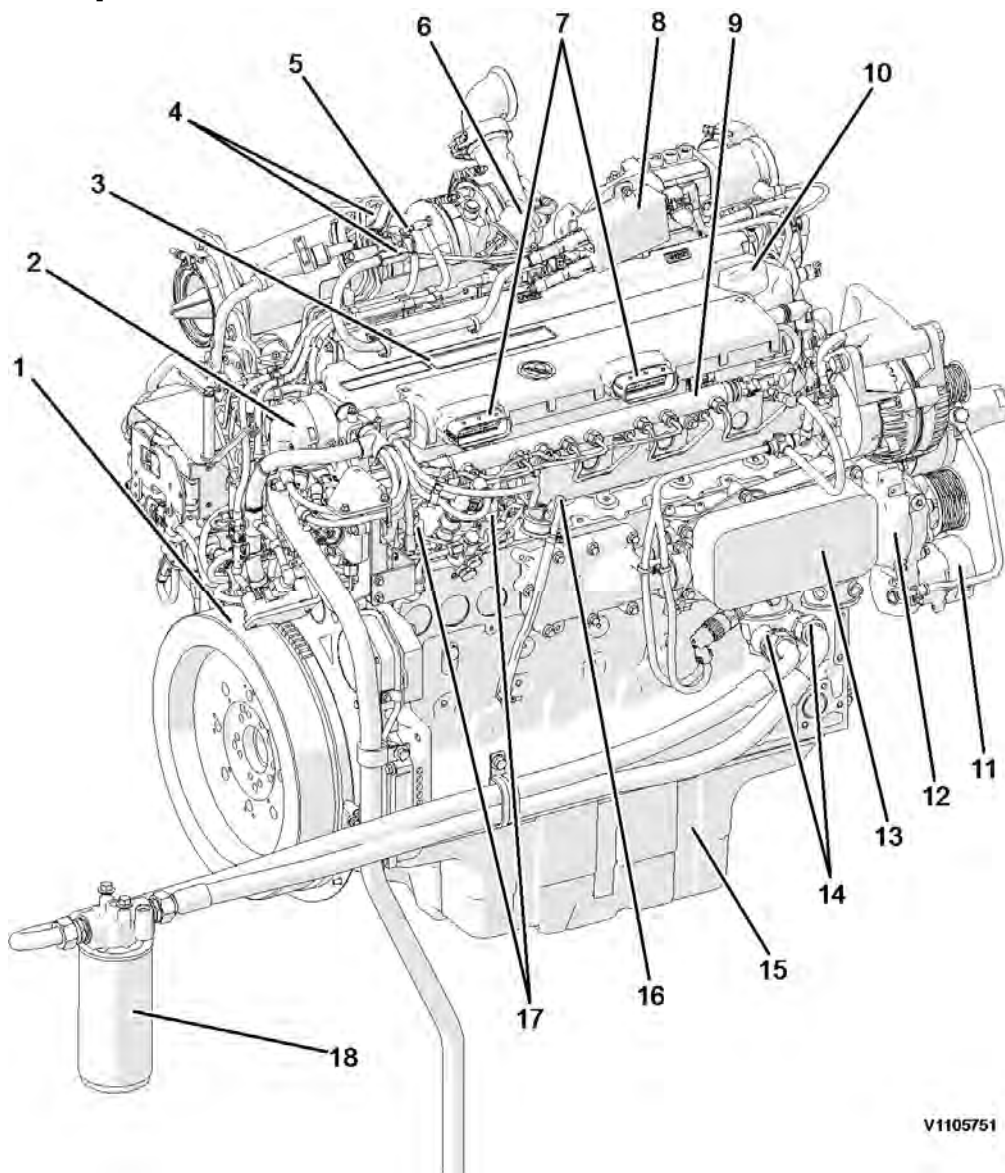

V1105751

**Figure 1**  
**Engine, front side**

1	Flywheel	10	Engine oil filling port
2	Crankcase ventilation duct	11	Belt tensioner
3	Valve cover	12	Coolant pump
4	Spark plug	13	Engine oil cooler
5	Glow plug	14	Engine oil filter remote port
6	Turbocharger waste-gate	15	Oil pan
7	ECU connecting port	16	Engine oil dipstick gauge

8	Spark plug control unit	17	High pressure fuel pump
9	Common rail	18	Engine oil filter

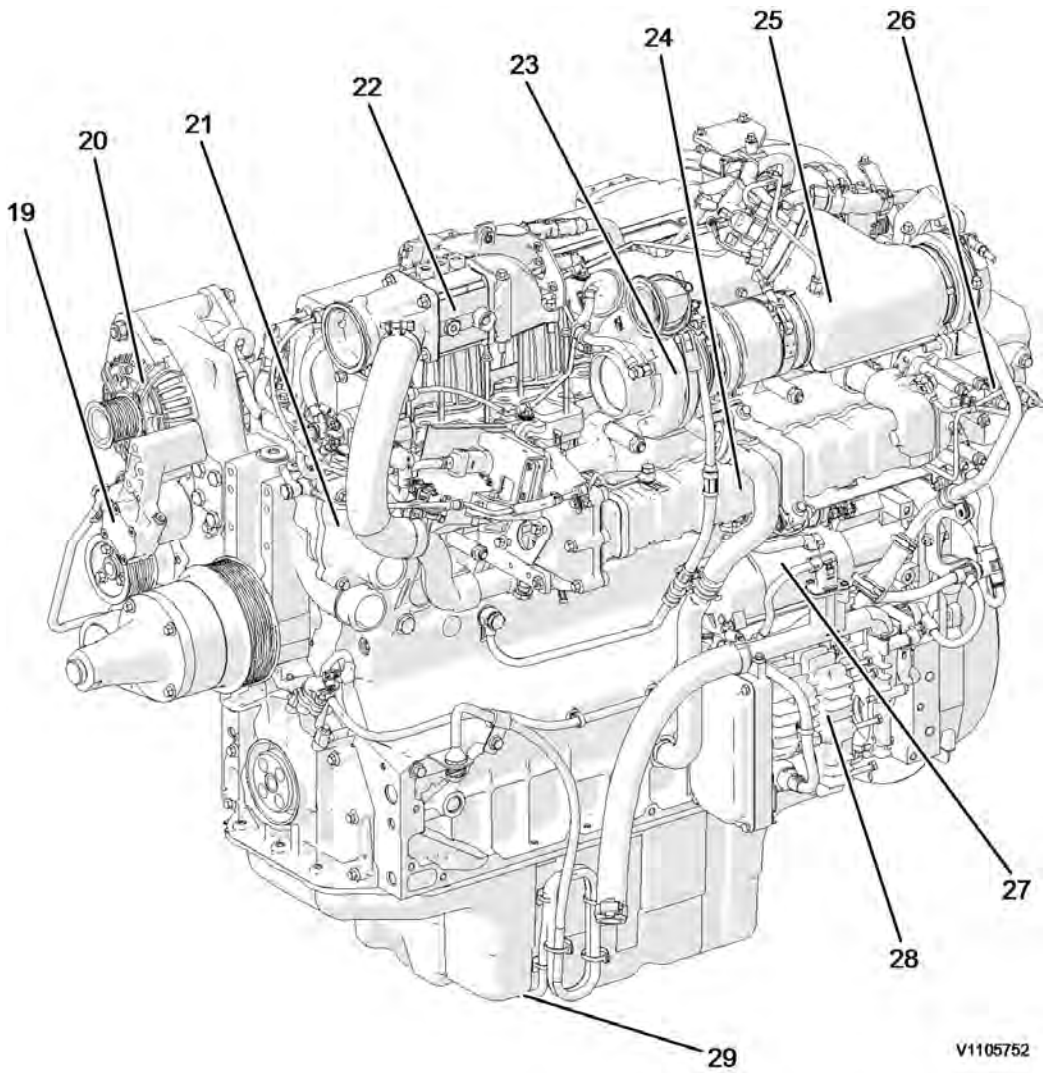

V1105752

**Figure 2**  
**Engine, back side**

19	Fuel feed pump	25	Partial flow-burner
20	Alternator	26	EGR actuator
21	Thermostat housing	27	Starter motor
22	Pre-heating coil housing	28	Electric air pump
23	Turbocharger	29	Engine oil level sensor
24	EGR cooler		

Document Title: <b>E-ECU, MID 128, changing non-programmed ECU</b>	Function Group: <b>200</b>	Information Type: <b>Service Information</b>	Date: <b>2014/9/28</b>
Profile: <b>EXC, ECR235D L [GB]</b>			

## E-ECU, MID 128, changing non-programmed ECU

Op nbr 200-068

[VCADS Pro VCADS Pro Service Tool](#)

[88890180 Interface](#)

[88890027 Cable](#)

1. Park the machine in the service position A, see [091 Service positions](#).
2. Open the side door on the left side of the machine.
3. Turn OFF the battery disconnect switch.



V1109236

**Figure 1**

4. Download software to VCADS Pro computer for target machine.
5. Connect the VCADS Pro computer to the machine, and perform the operation '28423-7 MID 128 control unit, programming'.
6. When VCADS Pro 'MID 128 ECU, programming' window appears, follow the instructions for replacing E-ECU.
7. Open the cover.



V1109982

**Figure 2**

8. Disconnect the wiring harness connectors from E-ECU and remove 2 screws fixing the clamps.

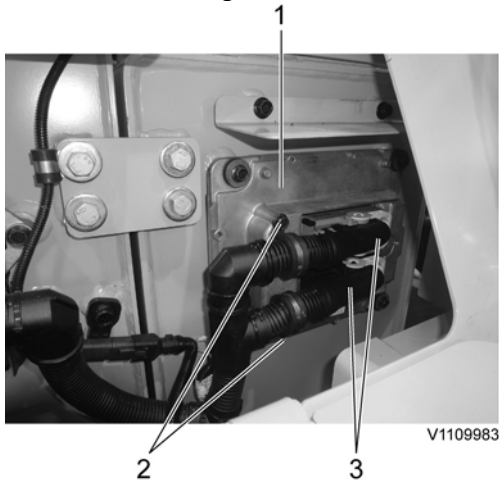

**Figure 3**

1. E-ECU
2. Connector
3. Screw

**NOTE!**

Pull up the locking device to disconnect the connector.

9. Remove 4 screws fixing the E-ECU.
10. Install new E-ECU, and tighten 4 screws.
11. Connect the wiring harness connectors to the E-ECU and tighten 2 screws fixing the clamps.
12. After replacing E-ECU, press OK button of VCADS Pro operation '28423-7 MID 128 control unit, programming'. Now VCADS Pro starts the programming of software and parameters to the new E-ECU.

**NOTE!**

If not able to read out the parameters with the program operation, the VCADS Pro operation 25438-8 "Nox sensor, age compensation, reset" has to be performed.

13. Close the cover.

Document Title: <b>E-ECU, MID 128, changing pre-programmed ECU</b>	Function Group: <b>200</b>	Information Type: <b>Service Information</b>	Date: <b>2014/9/28</b>
Profile: <b>EXC, ECR235D L [GB]</b>			

## E-ECU, MID 128, changing pre-programmed ECU

Op nbr 200-070

[VCADS Pro VCADS Pro Service Tool](#)

[88890180 Interface](#)

[88890027 Cable](#)

1. Park the machine in the service position A, see [091 Service positions](#).
2. Open the side doors on the left side of the machine.
3. Turn OFF the battery disconnect switch.



V1109236

**Figure 1**

4. Connect VCADS Pro computer to the machine, and perform the operation '17030-3 Parameter, programming'.
5. Use the function 'save all parameters to job card'.
6. Open the cover.



V1109982

**Figure 2**

7. Disconnect the wiring harness connectors from E-ECU and remove 2 screws fixing the clamps.

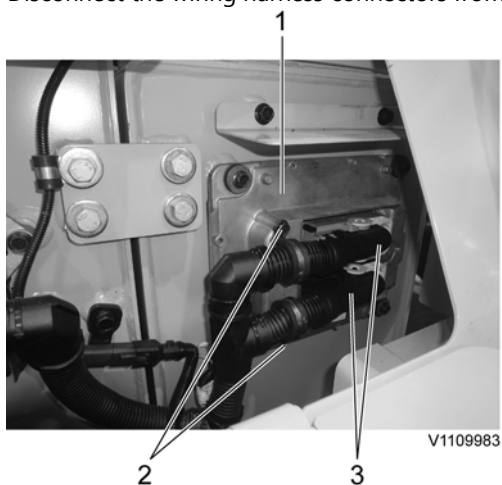

**Figure 3**

1. E-ECU
2. Connector
3. Screw

**NOTE!**

Pull up the locking device to disconnect the connector.

8. Remove 4 screws fixing the E-ECU.
9. Install new E-ECU, and tighten 4 screws fixing the E-ECU.
10. Connect the wiring harness connectors to the E-ECU and tighten 2 screws fixing the clamps.
11. Connect VCADS Pro computer to the machine, and perform the operation 17030-3 Parameter, programming'. Now the customer parameters are changed according to the job card saved at step 2.
12. Perform VCADS Pro operation 25438-8 "Nox sensor, age compensation, reset".
13. Close the cover.

Document Title: <b>Engine, removing</b>	Function Group: <b>210</b>	Information Type: <b>Service Information</b>	Date: <b>2014/9/28</b>
Profile: <b>EXC, ECR235D L [GB]</b>			

## Engine, removing

Op nbr 210-070

### **WARNING**

**Risk of burns - stop the diesel engine and allow it to cool down before starting any work.**

### **WARNING**

**Removal of residual pressure from the circuit must be done prior to any maintenance.**

#### **NOTE!**

Cable ties and clamps that secure hoses and electrical wiring must be removed and then replaced when installing components.

#### **NOTE!**

Disconnected hoses, lines and connections must be plugged. Oil that drains from hoses, lines and connections should be collected in a container.

1. Place the machine in the service position B. See [091 Service positions](#)
2. Turn off the battery disconnect switch.
3. Drain the coolant in a collection container. See [261 Coolant, changing](#).
4. Remove the cabin, see [810 Cab, removing](#).
5. Remove the DPF hood and the radiator hood.

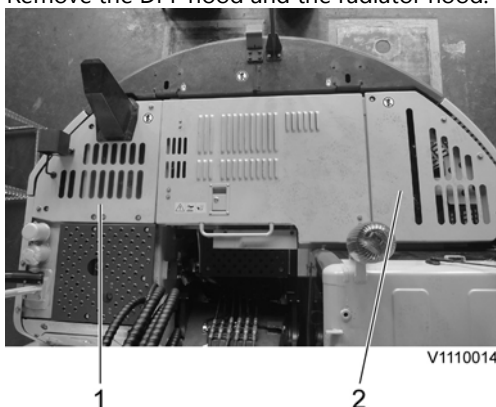

**Figure 1**

1. DPF hood
  2. Radiator hood
6. Open the engine hood, disconnect the boost sensor and the air inlet hoses. Remove the screws on the bracket and the air inlet pipe.

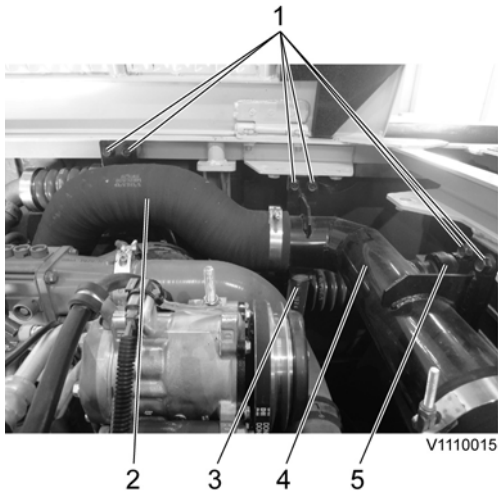

**Figure 2**

1. Screw
2. Air inlet hose
3. Air pump inlet hose
4. Air inlet pipe
5. Boost sensor

7. Remove the engine hood with the upper cowl frame.

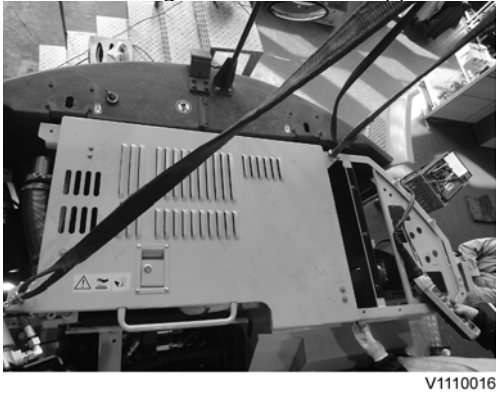

**Figure 3**

8. Remove the cowl frame behind the cabin.

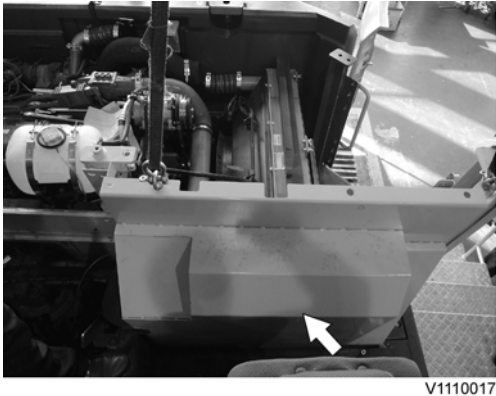

**Figure 4**

9. Remove the clamps, screw and the charge air cooler hoses.



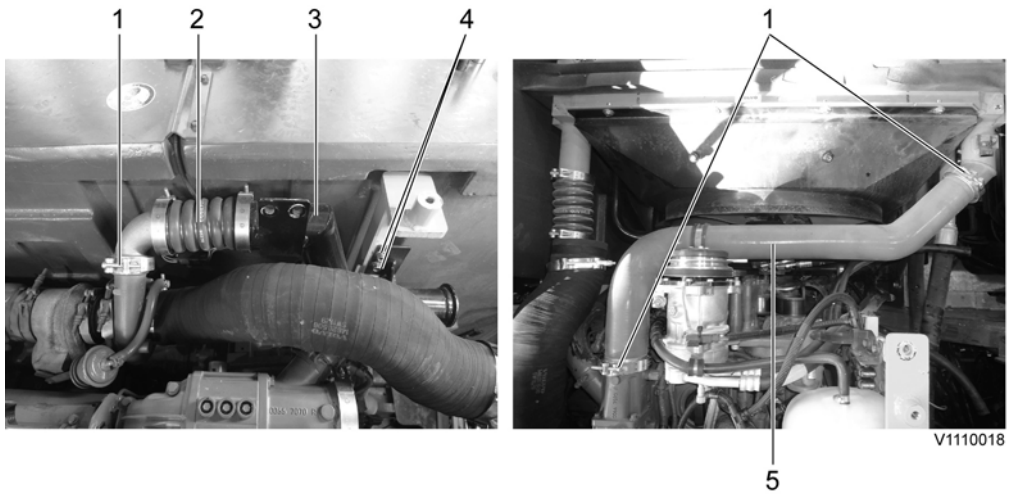

**Figure 5**

1. Clamp
2. Charge air cooler hose (Outlet)
3. Bracket
4. Screw
5. Charge air cooler hose (Inlet)

10. Remove the air inlet hose.



**Figure 6**

1. Air inlet hose
11. Remove the clamps and disconnect the radiator hoses.

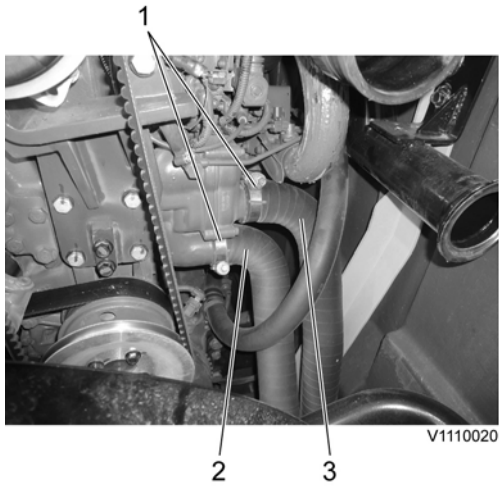
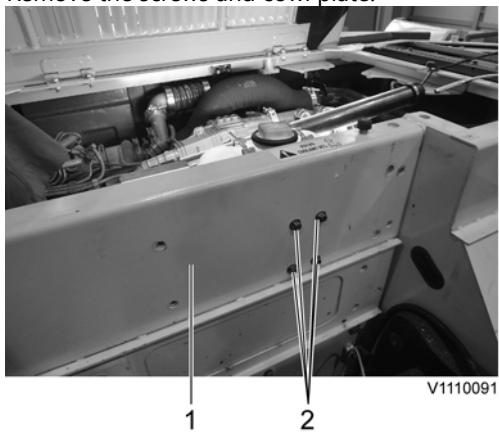

**Figure 7**

1. Clamp
2. Radiator hose (Outlet)
3. Radiator hose (Inlet)

12. Remove the main pump. See [913 Hydraulic pump, replacing](#)

13. Remove the screws and cowl plate.



**Figure 8**

1. Cowl plate
2. Screw

14. Disconnect the hose on the top side of the expansion tank.

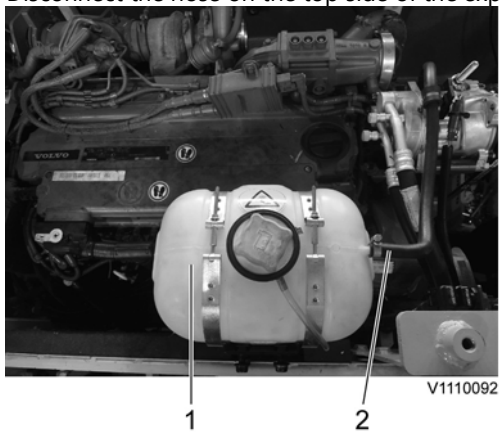

**Figure 9**

1. Expansion tank
2. Hose

15. Disconnect wire harness connector and the hoses.  
Remove the expansion tank.

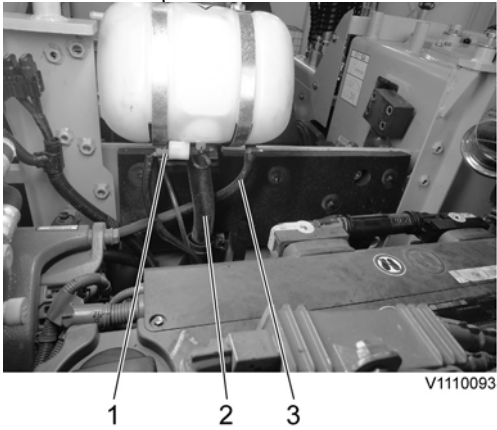

**Figure 10**

1. Wire harness connector
2. Hose
3. Hose

16. Remove the cowl plate.

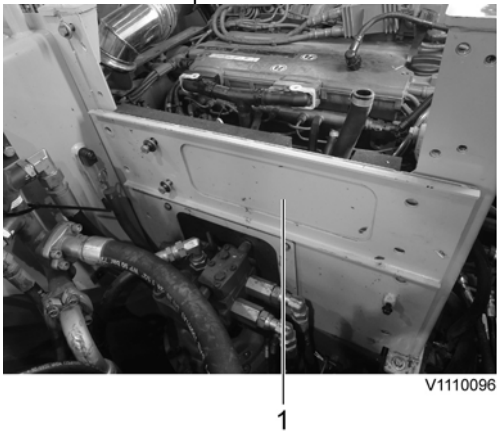

**Figure 11**

1. Cowl plate

17. Disconnect the engine block heater wire-harness and the cab heater hose.

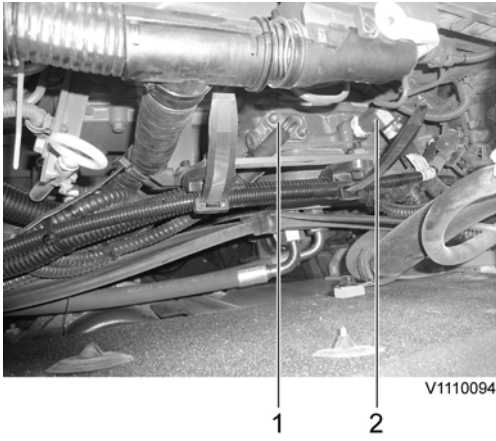

**Figure 12**

1. Engine block heater wire-harness (optional)
2. Cab heater hose (supply)

18. Disconnect the fuel line hoses (4 pcs) and remove the bracket

**NOTE!**

Ports must be plugged after disassembling hoses.

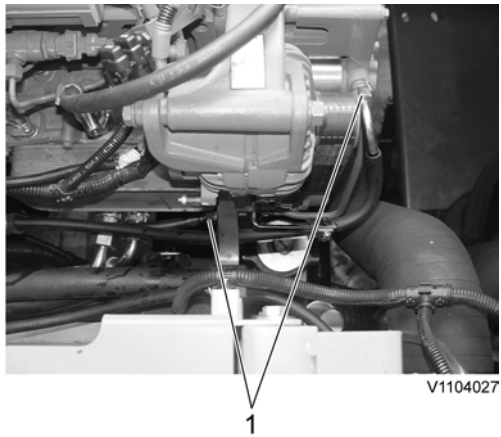
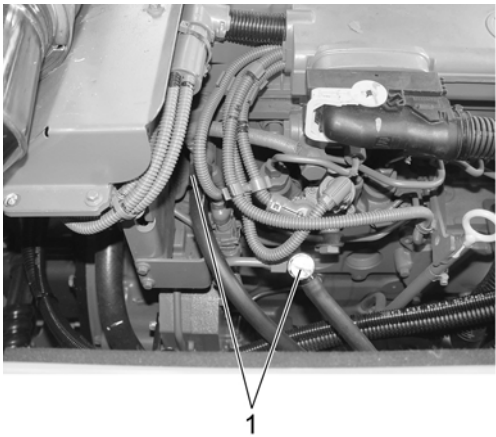

**Figure 13**

1. Fuel hose
2. Bracket

19. Disconnect the engine oil remote hoses.

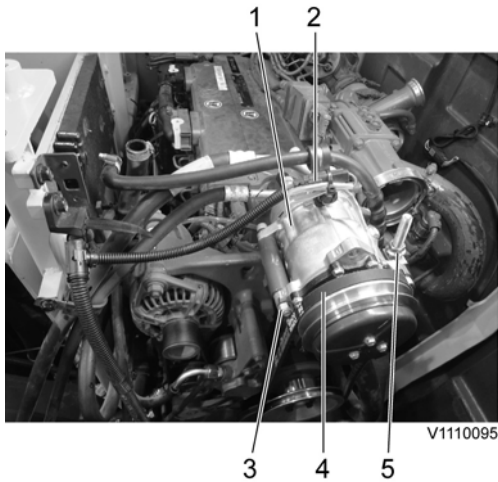

**Figure 14**

1. Engine oil remote hose
20. Disconnect the wire harness connector, remove the compressor and lay it down on the frame.

**! WARNING**

**Do not disconnect or loosen connections for the air conditioning unit (AC). Risk of gas leakage.**



**Figure 15**

1. Air conditioner compressor
2. Wire harness connector
3. Mounting screw
4. Air conditioner compressor belt
5. Nut

21. Remove the clamp and disconnect the exhaust pipe.

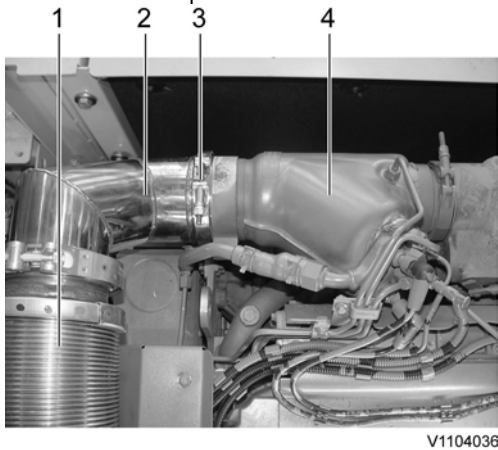

**Figure 16**

1. Exhaust flexible tube
2. Exhaust pipe
3. Clamp
4. Burner

22. Disconnect the starter motor wire harness.

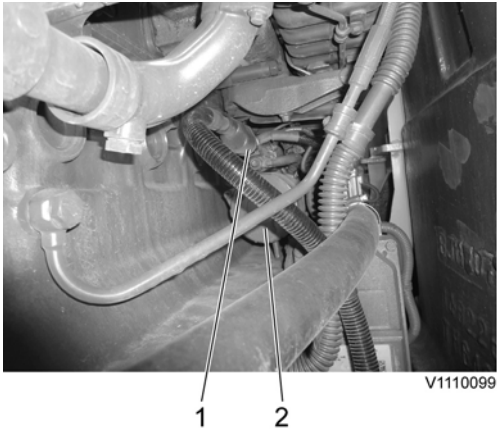

**Figure 17**

1. Starter motor wire harness

23. Disconnect the junction box connector.

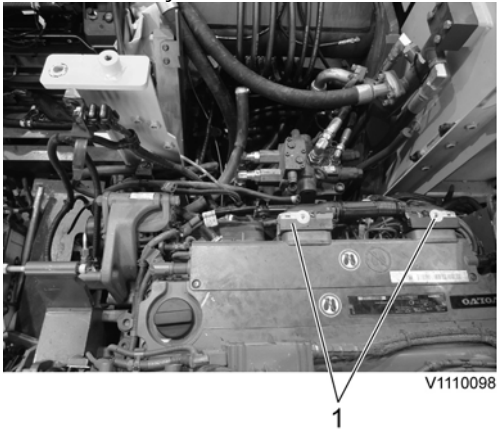

**Figure 18**

1. Junction box connector

24. Remove the screw and the clamp.

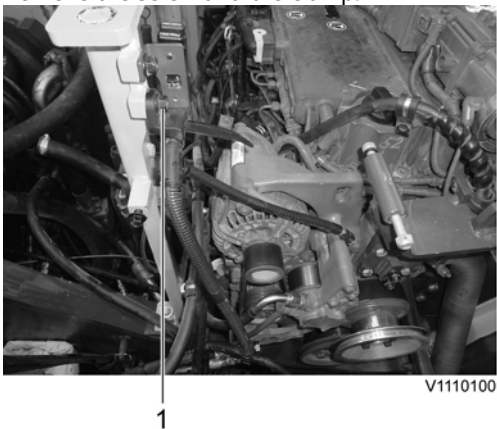

**Figure 19**

1. Screw

25. Remove the four mounting screws.

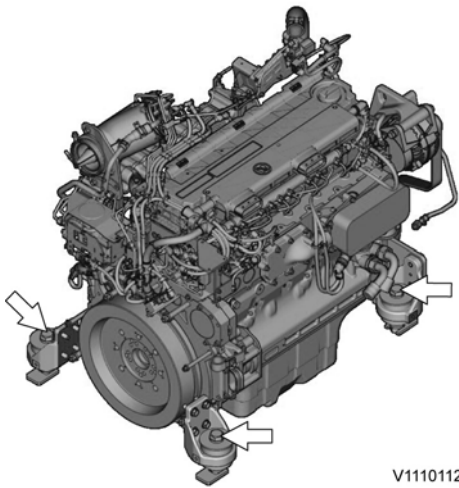

V1110112

**Figure 20**

26. Lift the engine just a little using a lifting device, and after confirming safety around, lift it up and out slowly to the work stand.

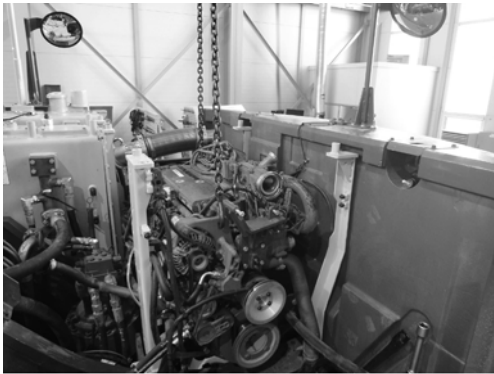

V1110101

**Figure 21**

Document Title: <b>Crankcase ventilation, description</b>	Function Group: <b>212</b>	Information Type: <b>Service Information</b>	Date: <b>2014/9/28</b>
Profile: <b>EXC, ECR235D L [GB]</b>			

## Crankcase ventilation, description

Since some of the combustion pressure enters the crankcase after passing by the pistons and piston rings (blow-by), the crankcase must be ventilated.

The purpose of the crankcase ventilation is to balance the pressure in the crankcase in order to avoid damage to engine components and to prevent oil mist formation and oil leakage into the ambient air.

The crankcase ventilation consists of a housing containing a filter, with connections to the oil sump and ventilation piping.

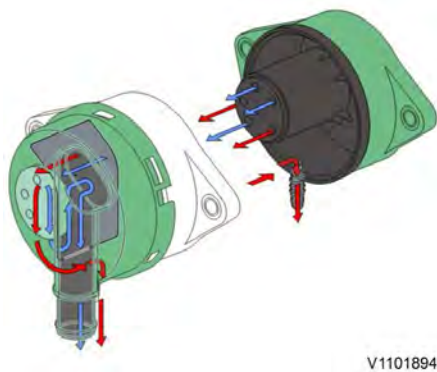

**Figure 1**  
**Crankcase ventilation housing**

Air containing oil particles comes from the crankcase via the cylinder head into the crankcase ventilator. The air (blue arrows) passes through the filter, while oil particles (red arrows) are caught and led back to the oil sump via a return pipe.

### Supplementary information

- [200 Engine, description](#)
- [200 Component locations](#)



Document Title: <b>Valves, adjusting</b>	Function Group: <b>214</b>	Information Type: <b>Service Information</b>	Date: <b>2014/9/28</b>
Profile: <b>EXC, ECR235D L [GB]</b>			

## Valves, adjusting

Op nbr 214-012

[9998681 Rotation tool](#)

[885812 Timing tool](#)

### **! WARNING**

**Risk of burns - stop the diesel engine and allow it to cool down before starting any work.**

### **NOTICE**

**Never adjust the valves with the engine running as the valves may strike the piston and cause serious damage.**

### **NOTICE**

**Always cover open air connections with a plastic bag and rubber bands. Gravel, dust and other particles in these connections may result in engine failure!**

1. Place the machine in service position B. See [091 Service positions](#)
2. Open the engine hood.
3. Remove the heating guard

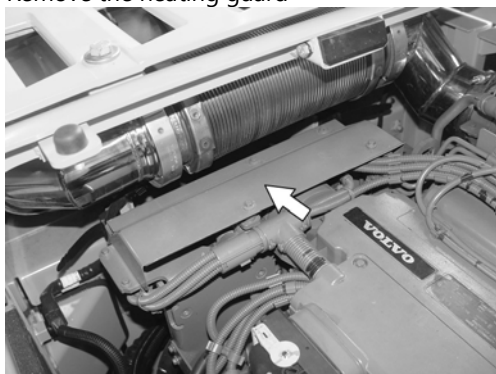

V1103092

**Figure 1**

4. Remove the screws and put aside the crankcase ventilation duct from the engine.

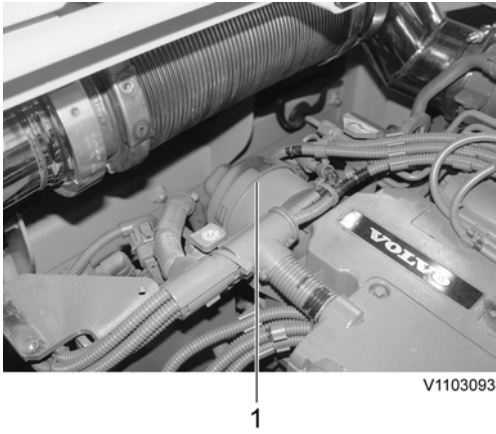

**Figure 2**

1. Crankcase ventilation duct

5. Disconnect the spark plug cables and connector. Remove the screws and spark plug control unit.

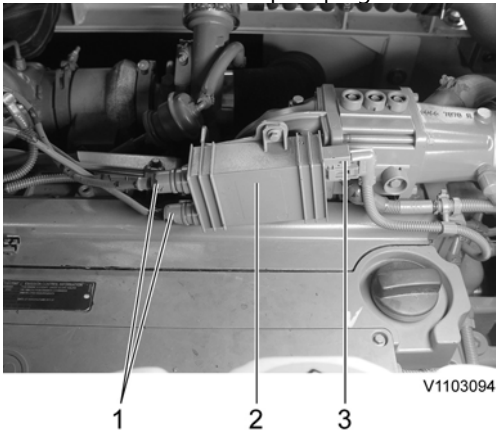

**Figure 3**

1. Spark plug cable
2. Spark plug control unit
3. Wire-harness connector

6. Disconnect the junction box connector and pull apart the cover plates

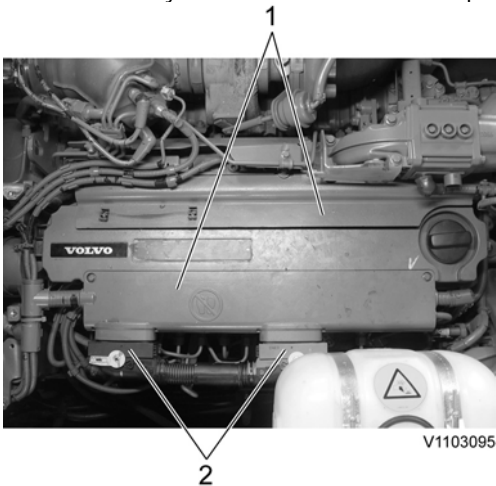

**Figure 4**

1. Cover plate
2. Junction box connector

7. Disconnect the connectors.

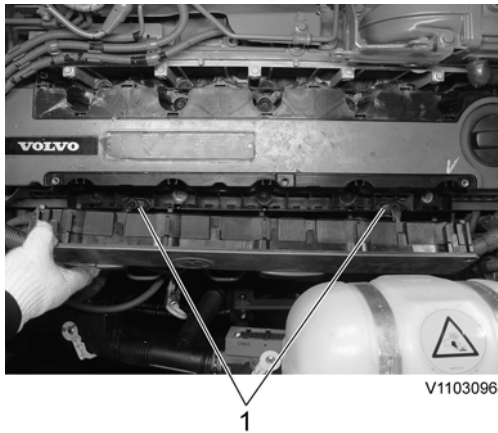

**Figure 5**

1. Connector

### **NOTICE**

**Clean round the valve cover, intercooler and turbo to avoid oil residue and the like from getting into the engine while work is in progress.**

8. Remove the valve cover.

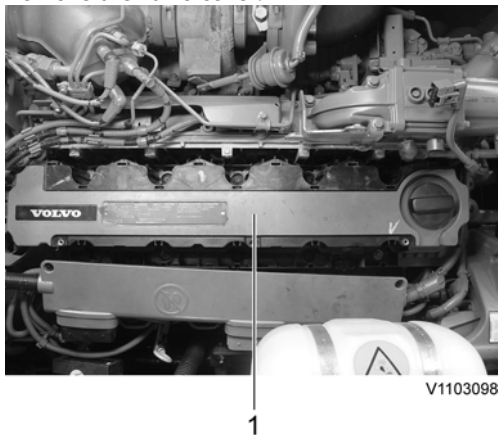
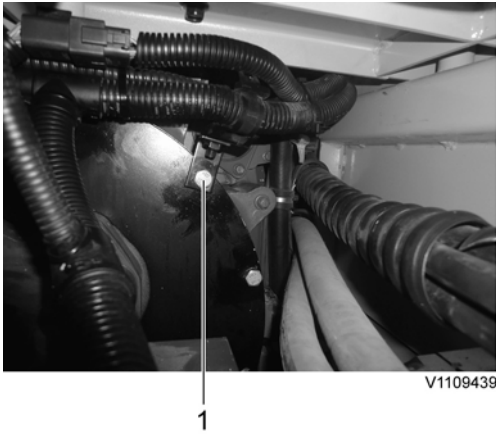

**Figure 6**

1. Valve cover

9. Open the side door on the right side of the machine.

10. Remove the clamp screw.



**Figure 7**

1. Clamp screw

11. Remove the gear cover.

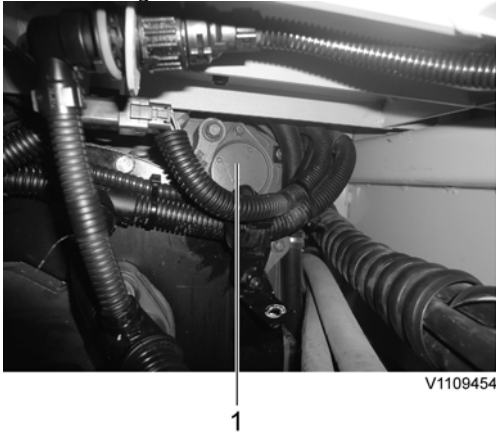

**Figure 8**

1. Gear cover

12. Install the engine rotating tool.

**NOTE!**

The teeth of the rotation tool must mesh fully with the teeth of the flywheel gear.

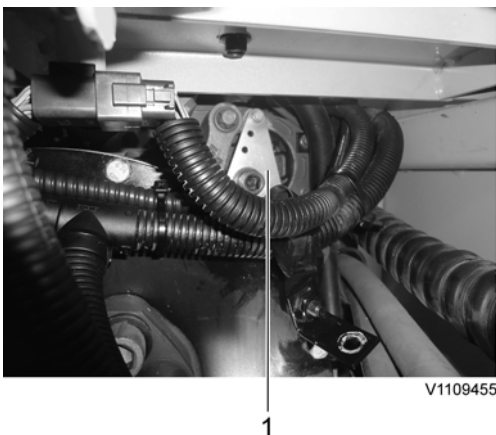

**Figure 9**

**Thank you very much for reading.**

**This is part of the demo page.**

**GET MORE:**

**Hydraulic**

**System, Setting**

**Instructions, Functional**

**Description, Electrical**

**System And more.....**

**Click Here BUY NOW**

**Then Instant Download**

**the Complete Manual.**

- 9998681 Rotation tool

13. **Setting engine to valve overlap**

Turn the engine using the rotation tool until the valve overlap of cylinder 1 is reached.

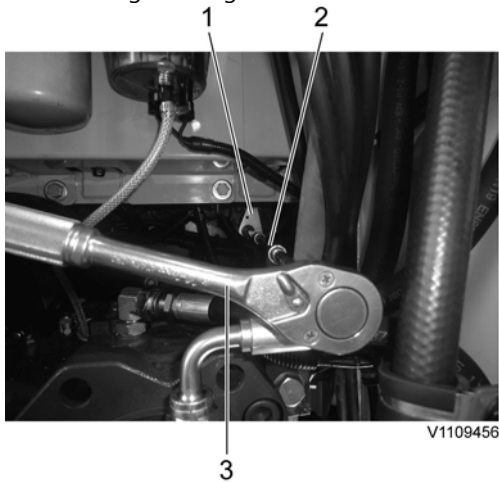

**Figure 10**

- 9998681 Rotation tool
- Extension bar
- Handle

- Crank the engine, clockwise, to a position where the valves on the cylinder number 1 (**closest to the flywheel side**) overlap. Overlapping means that the exhaust valve is about to open and the inlet valve is about to close. In this position it should not be possible to rotate any of the push rods by hand for the cylinder in question.

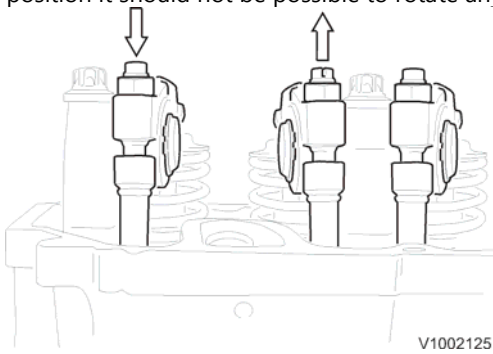

**Figure 11**  
**Overlapping**

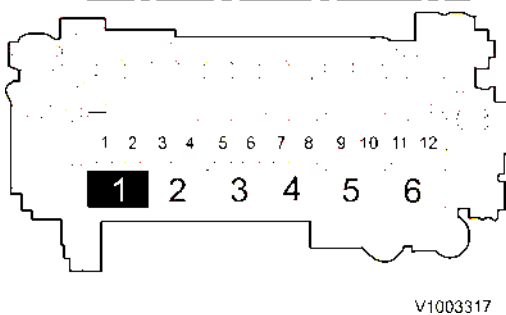
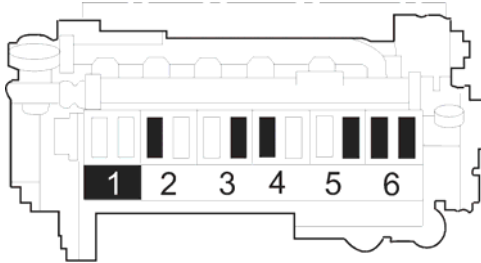

**Figure 12**

- 1, 3, 5, 7, 9, 11 are exhaust valves  
2, 4, 6, 8, 10, 12 are inlet valves

- Adjust the valve clearance for each cylinder according to **the black markings** in the figure. Procedure for adjusting:

1. Loosen the adjusting screw's lock screw on the rocker arm.
2. Install the timing tool on the adjusting screw.
3. Turn the adjusting screw until zero clearance is obtained between rocker arm and valve. Set the timing tool to zero.
4. Turn the adjusting screw **counter-clockwise  $75^\circ \pm 10^\circ$  for inlet valve** and  **$105^\circ \pm 10^\circ$  for exhaust valve**. see [214 Valve system, specification](#).
5. Hold the adjusting screw in position and at the same time tighten the lock nut. Tightening torque: See [210 Engine, tighten torques](#).



V1003318

**Figure 13**

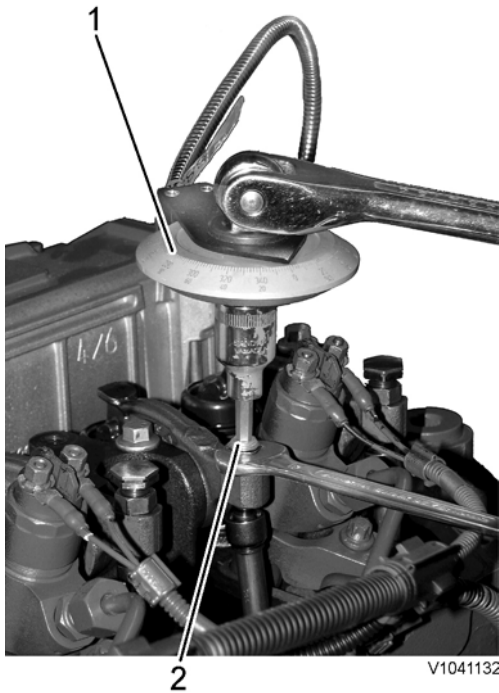

V1041132

**Figure 14**  
**Use of timing tool**

1. 885812 Timing tool
2. Adjusting screw

16. Turn the crankshaft one more revolution until the valves for cylinder number 6 overlap. Adjust the valve clearance for each cylinder according to **the black markings** in the figure.

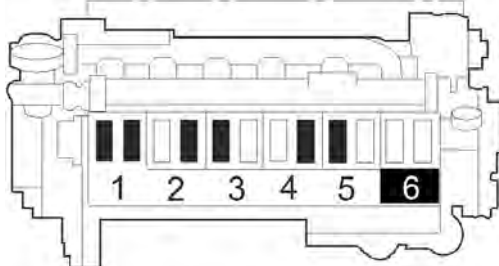

V1003319