

Document Title: Frame and track unit, specifications	Function Group: 700	Information Type: Service Information	Date: 2015/3/29
Profile:			

Frame and track unit, specifications

Specifications

Item	Unit	Specifications	
		Steel type	Rubber type
Length of undercarriage	mm	2495	
	in	98.2	
Track link pitch	mm	135	
	in	5.3	
Number of links	EA	39	
Number of top roller	EA	1 × 2	
Number of bottom roller	EA	5 × 2	
Spring	Type	– Hydraulic adjuster (grease)	
	Set length	mm (in)	240 (9.45) 227.5 (9.0)
	Set load	kg (lb)	3480 (7656) 4437 (9761)
	Adjust	mm (in)	-44 ~ 90 (-1.73 ~ 3.54)
Sprocket	Number of teeth	EA	21
	Width of sprocket tooth	mm (in)	42 (1.7)
Track shoe	Link height	mm (in)	70 (2.76)
	Number of shoes	EA	78
Ground contact pressure with standard digging unit (boom, arm and bucket)	350 mm width (Triple grouser)	kgf / cm ² (psi)	0.35 (5.0)
	380 mm width (Triple grouser)	kgf / cm ² (psi)	0.32 (4.6)
	400 mm width (Rubber)	kgf / cm ² (psi)	0.30 (4.3)

Document Title: Superstructure, installation	Function Group: 710	Information Type: Service Information	Date: 2015/3/29
Profile:			

Superstructure, installation

1. Bundle the hoses attached to the center passage together and place them upright.
2. Coat the screws and threaded holes of the slew ring with "Three bond 1215" (Loctite #515).

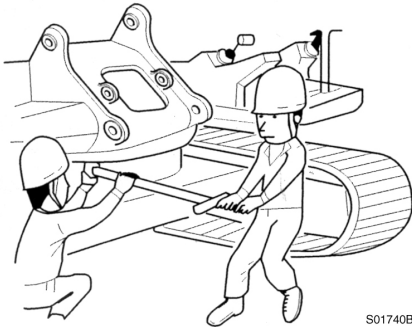

Figure 1
Installing the superstructure

3. Lift the superstructure and install it to the slew ring.
NOTE!
Lower the superstructure so that the slew pinion and the slew ring are engaged.
NOTE!
For tightening torque, see torque chart.
NOTE!
Tighten diagonally opposite screws in sequence.
4. Connect the hoses disconnected for removal.

Document Title: Superstructure, removal	Function Group: 710	Information Type: Service Information	Date: 2015/3/29
Profile:			

Superstructure, removal

! WARNING

The superstructure weighs approximate 2200 kg (4850 lb) (excluding cab and digging units). Pay attention to safe footing and the area around the crane before proceeding to remove or install the superstructure.

1. Remove the digging unit.
2. Dismantle the cab, and engine hood.
3. Disconnect hydraulic oil hoses, drain hose, and one servo hydraulic oil hose from center passage.

NOTE!

Bundle the hoses.

NOTE!

Blind plug each disconnected hose and pipe.

4. Place a wire rope on the superstructure and lift it with a crane to an extent that the wire rope is not slack.

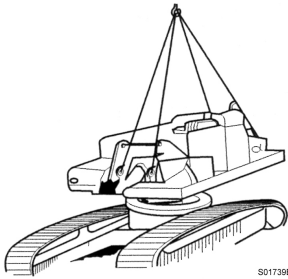

Figure 1
Lifting the superstructure

5. Remove screws (A) fixing the outer race of the slew ring.

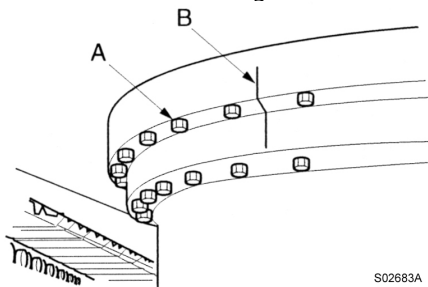

Figure 2
Slew ring installed

- A . Screw
- B . Confirm alignment of match marks

6. Lift the superstructure just a little, and after confirming safety all around, lift it up and out.

Document Title: Additional counterweight or attachment	Function Group: 716	Information Type: Service Information	Date: 2015/3/29
Profile:			

Additional counterweight or attachment

When special attachments are installed on the excavator, an additional counterweight is required for stability. In these cases, check the attachment specification and compare it carefully to the excavator load lifting capacity chart. And if in doubt, contact your local dealer for advice.

Additional counterweight can be installed according to special attachments, however we are not responsible for any failure of the excavator or breakage of attachments due to such application.

For reference, an excavator is basically designed only for excavating and is not designed to be used as a crane.

Document Title: Counterweight, installation	Function Group: 716	Information Type: Service Information	Date: 2015/3/29
Profile:			

Counterweight, installation



WARNING

Lift the counterweight just a little, and after confirming safety all around, proceed to install it.

- Lift the counterweight to the desired position.

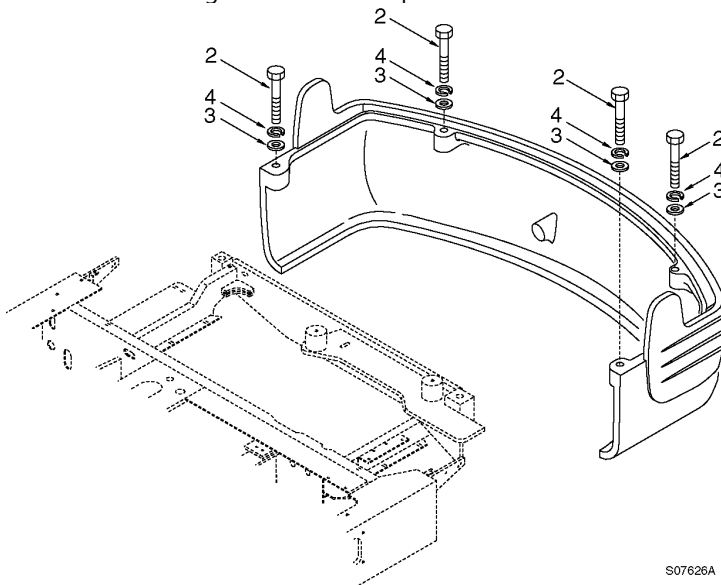

Figure 1
Position, lifting and mounting

- Match the screw hole. Insert the lock spring washer (4) and the plain washer (3), and tighten screw (2).
 - Lower the counterweight to the mounting face at the rear of the superstructure.
 - Tightening torque : kgf·m (lbf·ft)**

Mounting screw (2)	Torque
Inside	9.5 ± 0.9 (68.7 ± 6.5)
Outside	26.7 ± 2.7 (193 ± 19)
NOTE! Screw thread : apply loctite #601.	

- Maintain the clearance (upper, lower, left, right) within 5 ~ 10 mm (0.197 ~ 0.394 in).

Document Title: Counterweight, removal	Function Group: 716	Information Type: Service Information	Date: 2015/3/29
Profile:			

Counterweight, removal



WARNING

The counterweight weighs 240 kg (529 lb). Take care in performing removal. To lift the counterweight, use certified wire ropes in good condition, of adequate load rating and length.

1. Attach wire slings to the lifting eyes at the top surface of the counterweight and lift until there is no slack in the wire ropes.
2. Remove screws (3), using socket wrench or power wrench.
3. Lift the counterweight just a little, and after confirming safety all around, lift it up and out.

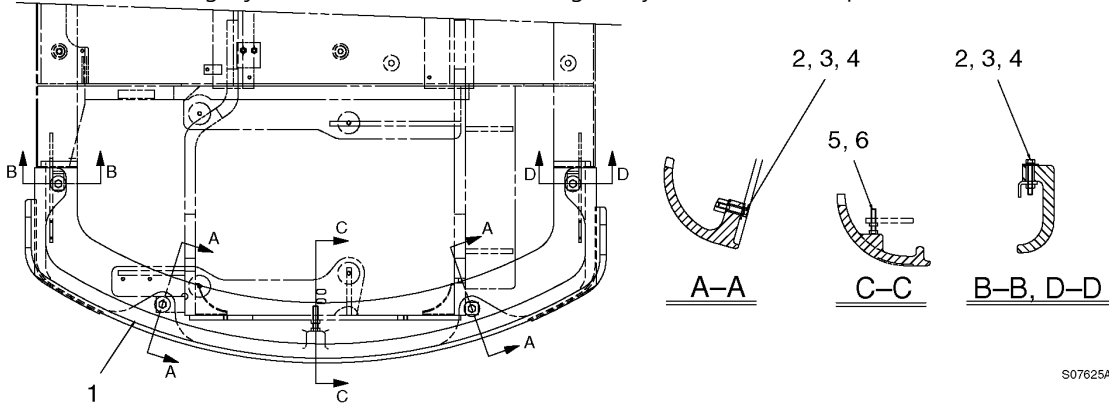

S07625A

Figure 1
Removing the counterweight

1 Counterweight	4 Spring washer
2 Screw	5 Nut
3 Plain washer	6 Screw

Document Title: Undercarriage, description	Function Group: 7181	Information Type: Service Information	Date: 2015/3/29
Profile:			

Undercarriage, description

Undercarriage consists of idlers, springs, top and bottom rollers, sprockets, track links, track frame and track guards.

Steel track (standard)

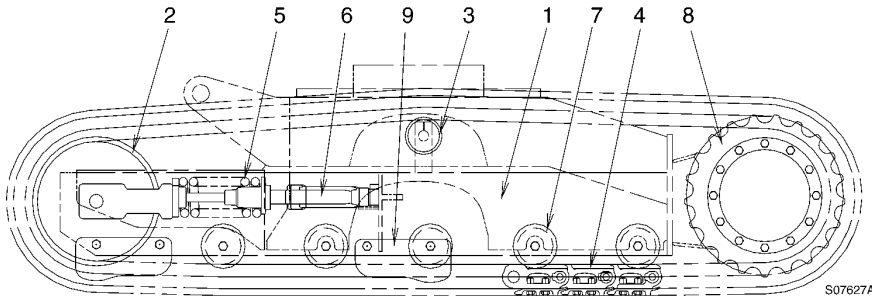

Figure 1
Structure, undercarriage (steel)

1	Track frame	6	Track sag adjusting cylinder
2	Idler	7	Bottom roller
3	Top roller	8	Sprocket
4	Track chain	9	Track guard
5	Recoil spring		

Rubber track (option)

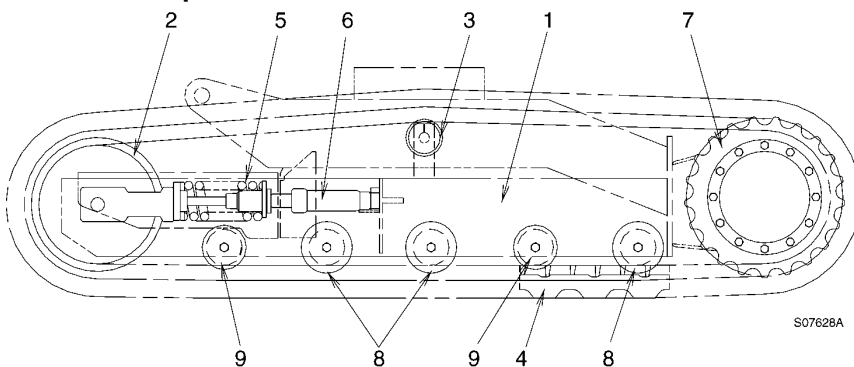
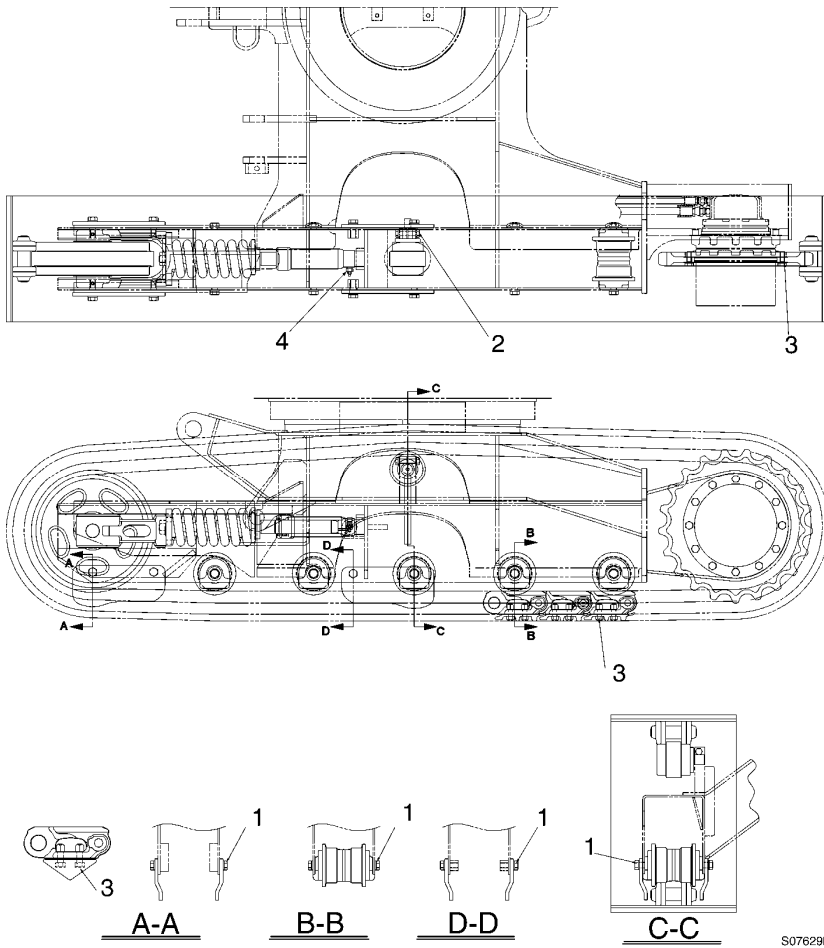

Figure 2
Structure, undercarriage (rubber)

1	Track frame	6	Track sag adjusting cylinder
2	Idler for rubber track	7	Sprocket
3	Top roller	8	Bottom roller (double flange roller)
4	Rubber track	9	Bottom roller (single flange roller)
5	Recoil spring for rubber track		

Tightening torque



S07629B

Figure 3
Tightening torque, kgf-m (lbf-ft)

1	27 ± 3 (195 ± 22)	3	18 ± 2 (130 ± 14)
2	11 ± 2 (79 ± 14)	4	7 ± 0.5 (50 ± 4)

- Loctite should be applied to screw tightening area (except shoe screw).

Document Title: Selection of track shoes	Function Group: 775	Information Type: Service Information	Date: 2015/3/29
Profile:			

Selection of track shoes

Choose suitable track shoes to match the ground conditions.

Method of selecting shoes

Confirm the category from the list of uses in the following table then use the table "Selection, track shoes" to select the shoe.

Categories "B" and "C" are optional shoes, so there are restrictions on their use. Therefore, before using, check the restrictions and consider carefully the conditions of use before selecting a suitable shoe width. If necessary, give the customer guidance in their use.

When selecting the shoe width, select the narrowest possible within the range that will give no problem with flotation and ground pressure. If a wider shoe than necessary is used, there will be a large load on the shoe, and this may lead to bending of the shoe, cracking of the links, breakage of the pins, loosening of the shoe screws, or other problems.

Category, track shoes

Category	Use	Precautions when using
A, C	Rocky ground, normal soil	Travel in low speed when traveling on rough ground with obstacles such as large boulders and fallen trees.
A, C	Soft ground	Travel in high speed only on flat ground. When it is impossible to avoid traveling over obstacles, lower the travel speed to approximate half of low speed.  Cannot be used on rough ground where there are large obstacles such as boulders and fallen trees.
B	Pavement	Use only on pavement to protect the rubber pad shoe. Be careful for working on concrete crushed pieces or sand, on reinforcing bars or protected pieces of glass, on concrete sideways, rocky ground and on stoney river beds. Be careful not to slip on water, snow, or sand. Especially, be careful when loading and unloading the machine.

Track shoes, unit : kgf/cm2 (psi)

Type	Width, mm(in)	Type	Contact pressure
A	380 (15.0)	Standard	0.32 (4.544)
B	400 (15.7)	Rubber track	0.30 (4.266)
C	350 (13.8)	Narrow	0.35 (4.977)

Document Title: Idler, description	Function Group: 7751	Information Type: Service Information	Date: 2015/3/29
Profile:			

Idler, description

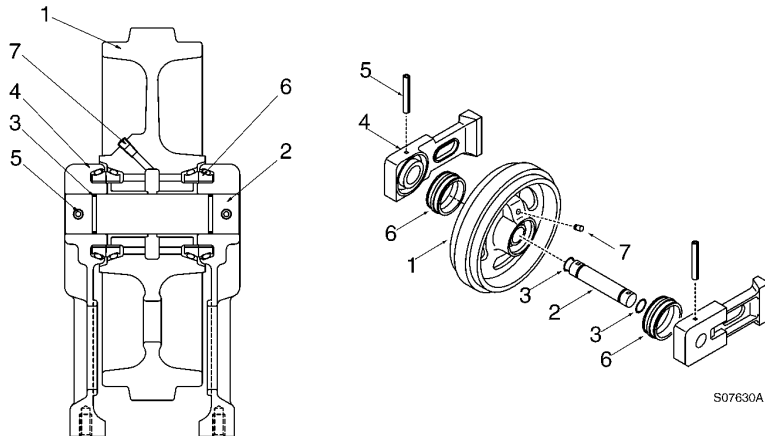

S07630A

Figure 1
Structure, idler

1	Idler wheel	5	Spring pin
2	Shaft	6	Seal kit
3	O-ring	7	Plug
4	Bracket		

Document Title: Idler, installation	Function Group: 7751	Information Type: Service Information	Date: 2015/3/29
Profile:			

Idler, installation

Installation of the idler and the spring package

1. Tighten connecting screws (1) of idler and track spring.
2. Pass a wire rope around the spring package bracket, lift the idler assembly, then fit and push the slide block into the slide groove in the track frame.



Confirm that the boss at the piston end of the spring package is in the track frame hole.

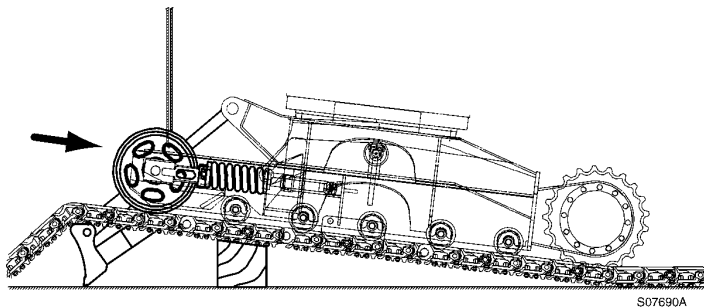

Figure 1
Installing, idler assembly

3. Install the track chain.

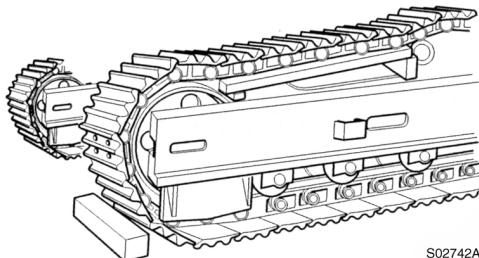

Figure 2
Installing, track chain

Document Title: Idler, measurement of wear	Function Group: 7751	Information Type: Service Information	Date: 2015/3/29
Profile:			

Idler, measurement of wear

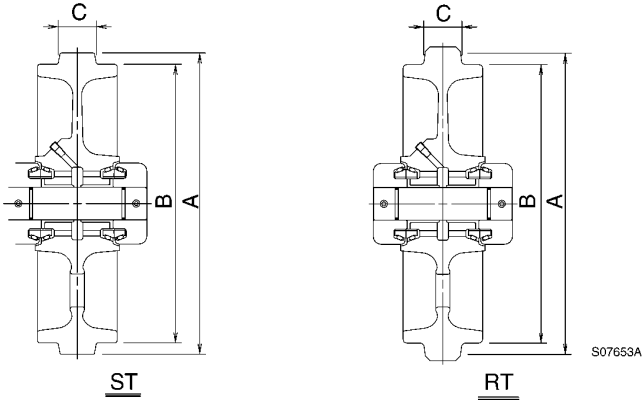

Figure 1
Idler, measurement of wear

- ST Steel track
- RT Rubber track

Limit of wear, unit : mm (in)

No.	Check item	Standard size		Repair limit		Remedy	
		Standard size	Tolerance	Standard	Repair limit		
A	Outer diameter of flange	Steel track	372 (14.7)	-		Replace	
		Rubber track	388 (15.3)	-			
B	Outer diameter of tread	344 (13.5)	334 (13.2)		Replace		
C	Width of flange	48 (1.9)	40 (1.6)		Replace		
D	Clearance between shaft and bushing	Standard size	Tolerance		Clearance	Replace bushing	
		40 (1.6)	Shaft	Hole	Standard		Repair limit
			-0.010 ~ -0.035 (-0.0004 ~ -0.0014)	0.185 ~ 0.140 (0.0073 ~ 0.0055)	0.15 ~ 0.22 (0.0059 ~ 0.0087)	1.5 (0.0591)	
E	Clearance between shaft and support	46 (1.8)	0.095 ~ 0.070 (0.0037 ~ 0.0028)	0.025 ~ 0 (0.0010 ~ 0)	0.045 ~ 0.095 (0.0018 ~ 0.0037)	-	Replace bushing

Document Title: Idler, removal	Function Group: 7751	Information Type: Service Information	Date: 2015/3/29
Profile:			

Idler, removal

Removal of the idler and the spring package

1. Remove the track chain.
2. Pass a wire rope around the track spring bracket, lift the idler assembly, and pull the bracket out of the track frame using a pry bar.

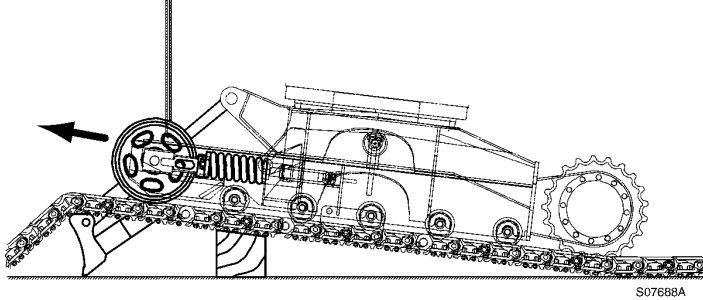

Figure 1
Removal, idler assembly

3. Remove connecting screws (1) of idler and spring package.

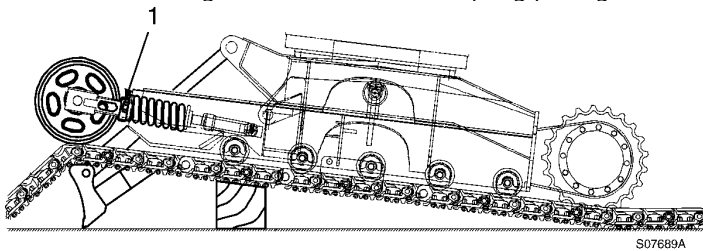

Figure 2
Removal, connecting screw

Document Title: Sprocket, installation	Function Group: 7752	Information Type: Service Information	Date: 2015/3/29
Profile:			

Sprocket, installation

The installation procedure is reverse order of removal.

1. Install the sprocket on the track gearbox.
2. Apply loctite #277 to the sprocket screws (1), and tighten them to the specified torque.

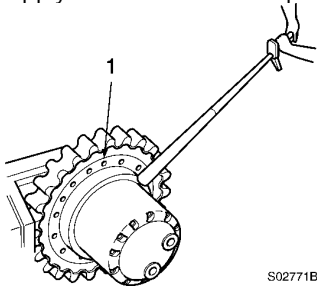

Figure 1
Screw in, screws

Document Title: Sprocket, measurement of wear	Function Group: 7752	Information Type: Service Information	Date: 2015/3/29
Profile:			

Sprocket, measurement of wear

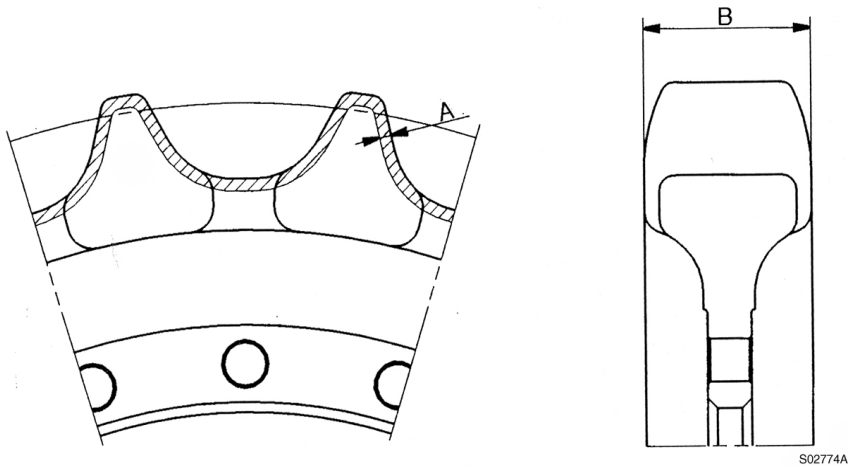

Figure 1
Sprocket

Wear limit, unit : mm (in)

Symbol	Item	Specifications	Repair limit	Remedy
A	Wear limit of sprocket tooth profile	–	5 (0.2)	Replace
B	Width of sprocket tooth	42 (21.7)	36 (1.4)	
C	Number of tooth	21 EA	–	–

Document Title: Sprocket, removal	Function Group: 7752	Information Type: Service Information	Date: 2015/3/29
Profile:			

Sprocket, removal

1. Remove the track.
2. Place a wooden block on the track, and place the undercarriage on the block to raise the sprocket off the track.
3. Remove the sprocket mounting screw (1), using a socket wrench.

Document Title: Track, adjusting track sag	Function Group: 7753	Information Type: Service Information	Date: 2015/3/29
Profile:			

Track, adjusting track sag

1. Slew the superstructure to the front, and raise the track using boom down operation and dozer blade operation.

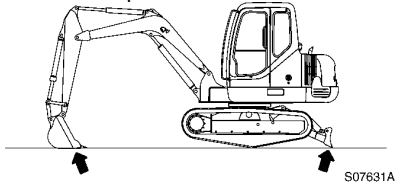

Figure 1
Raising the track

2. Slowly turn the track in forward and reverse direction several times. Stop the track while moving in the reverse direction.
3. Measure the track slack (A) at the center of track frame between track shoe and track roller mounting surface.

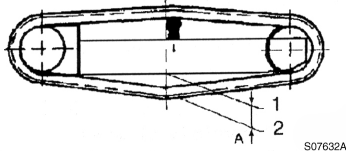

Figure 2
Measurement, track slack

1. Bottom side of frame
2. Upper side of shoe

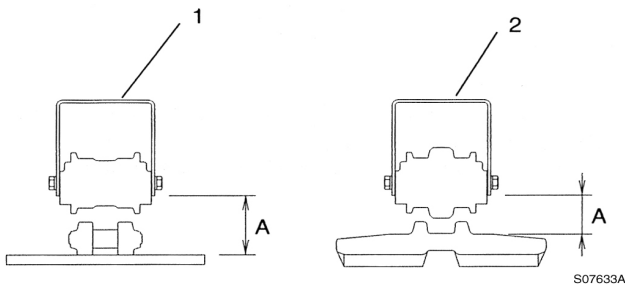

Figure 3
Adjusting, track sag

1. Steel track
2. Rubber track

WARNING

High pressure grease in track adjuster cylinder. Do not remove grease fitting or nut and valve assembly to release grease.

4. To decrease track sag, add multi-purpose grease to track adjuster cylinder through grease nipple (C) using a grease gun. To increase track sag, loosen valve assembly (B) one turn so that grease in the track adjuster cylinder can be drained. Tighten the valve assembly when track sag is correct.

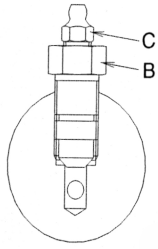

50763AA

Figure 4
Track adjuster cylinder

! CAUTION

If the piston in track adjuster cylinder does not move, replace the valve assembly, repair or replace the cylinder.

5. Adjust the track sag according to soil condition of work site. See the following table.

Track sag according to soil condition, unit : mm (in)

Working condition	Specifications (A)
Normal soil	130 ~ 140 (5.1 ~ 5.5)
Rocky ground	110 ~ 120 (4.3 ~ 4.7)
Soft ground (swamp, clay, sandy soil)	140 ~ 150 (5.5 ~ 5.9)
Rubber shoe	90 ~ 100 (3.5 ~ 3.9)

Document Title: Track chain, description	Function Group: 77531	Information Type: Service Information	Date: 2015/3/29
Profile:			

Track chain, description

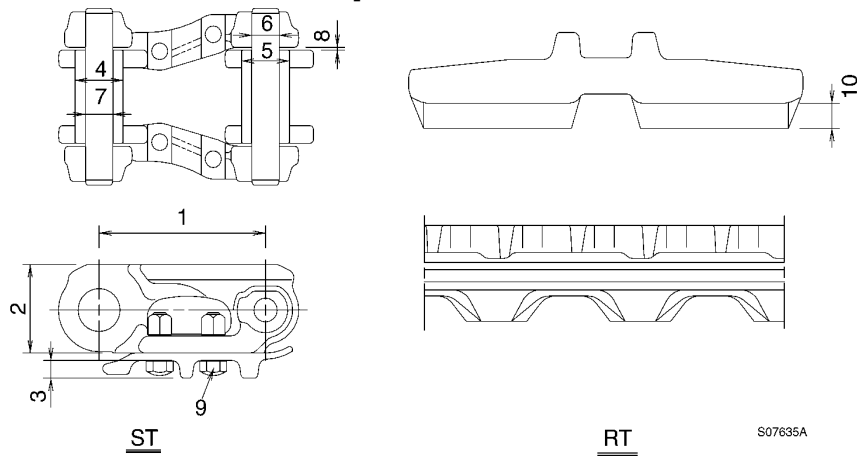
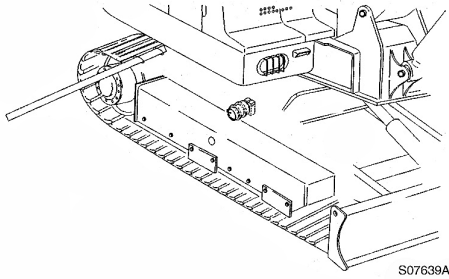

Figure 1
Structure, track chain

Document Title: Track chain, installation	Function Group: 77531	Information Type: Service Information	Date: 2015/3/29
Profile:			

Track chain, installation

1. While an assistant drives the machine slowly, insert a bar into the master pin bore located at the track end, and help the track engage with the sprocket tooth.



S07639A

Figure 1
Insertion, a bar into the master pin bore

2. When aligning the master pin bores in the track links, use wooden blocks A and B to support the track.

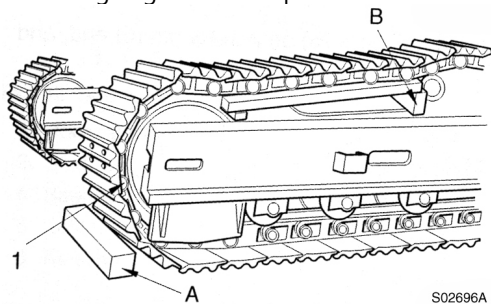

S02696A

Figure 2
Track, supporting

1. Master pin

Assembly of master pin

1. Connect master link (1) and general link (2), align pin bore (3) of master link (1) and the bore of (3) of master link (1) and the bore of master bushing (4) press-fitted to general link (2).
2. Insert master pin (5) into aligned bores (3), (4) with a hammer.

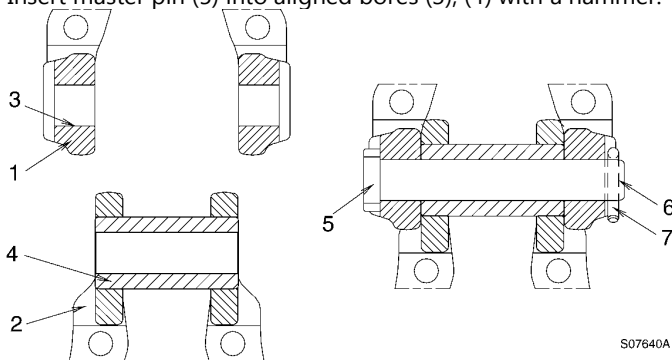

S07640A

Figure 3
Assembly, master pin

Thank you so much for reading.
Please click the “Buy Now!”
button below to download the
complete manual.



After you pay.

You can download the most
perfect and complete manual in
the world immediately.

Our support email:

ebooklibonline@outlook.com