

Document Title: Engine, description	Function Group: 200	Information Type: Service Information	Date: 2014/4/1 0
Profile: WLO, L60F [GB]			

Engine, description

D6E

D6E is a straight six-cylinder, four-stroke, turbocharged diesel engine with direct injection and intercooler, as well as wet, replaceable cylinder liners. The engine is equipped to meet governing legislation according to Tier 3/stage IIIA for exhaust emissions.

Engine D6E has a fuel system with Common Rail, which is controlled by the software in the engine's electronic control unit (E-ECU).

The D6E uses V-ACT (Volvo Advanced Combustion Technology). Engine D6EV with ACT features split injection, optimized air handling and, turbocharger with wastegate. Electronically controlled IEGR (Internal Exhaust Gas Recirculation) reduces NO_x contents and reduces emissions without the need for after-treatment of exhausts. All electronic functions in the engine are controlled by Volvo's latest engine management system, EMS2.

The engine's serial number is stamped on the name plate, on the cylinder block's side and on the valve cover. The engine's model designation and serial number must be indicated when ordering spare parts.

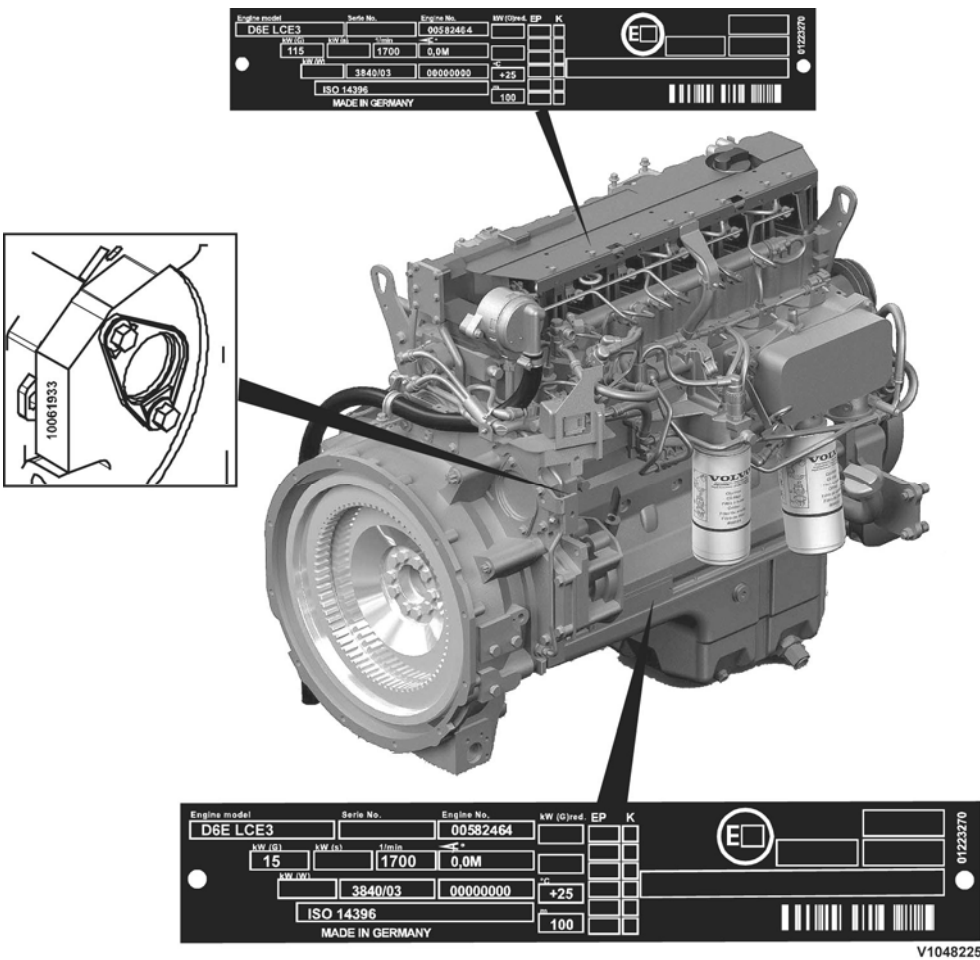
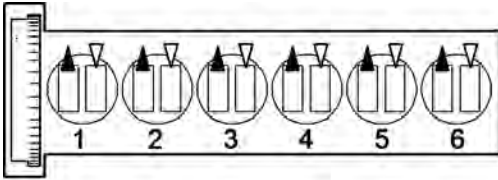

Figure 1

The cylinders are numbered in sequence, starting at the flywheel. Ignition order: 1-5-3-6-2-4. The engine's rotational direction is counter-clockwise, seen from the flywheel.



V1052456

Figure 2
Cylinder orientation

Engine protection — Software

The function informs the operator and limits the engine's rpm and torque as well as machine speed to prevent any engine damage. Engine shut-off takes place first when speed is below 2 km/h (1.2 mph). This makes it possible to move the machine away from hazardous situations before engine shut-off takes place.

The function is monitored by the engine control unit E-ECU and, depending on which component is generating the alarm, then any of the following functions is activated:

- reduction of engine's torque
- limitation of engine's rpm
- limitation of machine speed
- engine shut-down

See also [370 Wiring diagram 202](#), [370 Wiring diagram 203](#), [370 Wiring diagram 204](#) and [370 Wiring diagram 206](#)

Input signals	Conditions for output functions	Output functions
<ul style="list-style-type: none"> ○ Engine oil pressure, SE2203 	<ul style="list-style-type: none"> ○ (Critical) Low engine oil pressure ○ Low engine oil pressure ○ No or incorrect signal from the sensor 	<ul style="list-style-type: none"> ○ Red central warning ○ Warning — Low engine oil press. ○ Warning — Stop vehicleTurn Off Engine ○ Reduction of engine's torque ○ Amber central warning ○ Check — Engine failure
<ul style="list-style-type: none"> ○ Fuel control valve (FCV), PWM2303 	<ul style="list-style-type: none"> ○ Electrical malfunction. 	<ul style="list-style-type: none"> ○ Red central warning ○ Warning — Stop vehicleTurn Off Engine ○ Check — Injection system failure ○ Reduction of engine's torque ○ Reduces rail pressure with pressure relief valve (PRV)
<ul style="list-style-type: none"> ○ Rail pressure, SE2309 	<ul style="list-style-type: none"> ○ No or incorrect signal from the sensor 	<ul style="list-style-type: none"> ○ Red central warning ○ Warning — Stop vehicleTurn Off Engine ○ Check — Injection system failure ○ Limitation of engine rpm to 1100 rpm ○ Reduces rail pressure with

<ul style="list-style-type: none"> ○ EGR-valve, MA2504 	<ul style="list-style-type: none"> ○ Mechanical or electrical malfunction 	<p style="text-align: right;">pressure relief valve (PRV)</p> <ul style="list-style-type: none"> ○ Amber central warning ○ Check — Engine system failure ○ Reduction of engine's torque by max. 7% (to reduce the turbo's rpm)
<ul style="list-style-type: none"> ○ Charge air temperature, SE2507 	<ul style="list-style-type: none"> ○ (Critical) High charge-air temperature 92–100 °C (198–212 °F) ○ High charge-air temperature > 92°C / No or incorrect signal from the sensor 	<ul style="list-style-type: none"> ○ Red central warning ○ Warning — Stop vehicleTurn Off Engine ○ Warning — High charge-air temp. engine ○ Reduction of engine's torque dependent on charge-air temperature and engine rpm ○ Amber central warning ○ Check — High charge-air temp. engine ○ Reduction of engine's torque dependent on charge-air temperature and engine rpm
<ul style="list-style-type: none"> ○ Coolant level, SE2603 	<ul style="list-style-type: none"> ○ (Critical) Low coolant level ○ Low coolant level 	<ul style="list-style-type: none"> ○ Red central warning ○ Warning — Coolant level low ○ Amber central warning ○ Check — Coolant level lowCheck at next stop
<ul style="list-style-type: none"> ○ Coolant temperature, SE2606 	<ul style="list-style-type: none"> ○ (Critical) High coolant temperature 103–105 °C (217–221 °F) ○ High coolant temperature >100 °C (212 °F) ○ Electrical malfunction. 	<ul style="list-style-type: none"> ○ Red central warning ○ Warning — Stop vehicleTurn Off Engine ○ Warning — High coolant temp. engine ○ Reduction of engine's torque dependent on coolant temperature and engine rpm ○ Amber central warning ○ Check — High coolant temp. engine ○ Reduction of engine's torque dependent on coolant temperature and engine rpm ○ Amber central warning ○ Check — Engine failure

<ul style="list-style-type: none"> ○ Engine rpm flywheel, SE2701 	<ul style="list-style-type: none"> ○ No or incorrect signal from the sensor 	<ul style="list-style-type: none"> ○ Amber central warning ○ Check — Engine failure ○ Reduction of engine's torque by 2% per second ○ Max. torque engine 90%
<ul style="list-style-type: none"> ○ System error common rail 	<ul style="list-style-type: none"> ○ Defective functionality in the system 	<ul style="list-style-type: none"> ○ Red central warning ○ Warning — Stop vehicleTurn Off Engine ○ Check — Injection system failure ○ Reduction of engine's torque ○ Limitation of rail pressure to 80 MPa (800 bar), (11600 PSI) ○ Limitation of engine rpm to 1100 rpm
<ul style="list-style-type: none"> ○ System error power and torque output 	<ul style="list-style-type: none"> ○ Defective functionality in the system 	<ul style="list-style-type: none"> ○ Red central warning ○ Warning — Stop vehicleTurn Off Engine ○ Check — Injection system failure ○ Reduction of engine's torque ○ Limitation of rail pressure to 80 MPa (800 bar), (11600 PSI) ○ Limitation of engine rpm to 1100 rpm
<ul style="list-style-type: none"> ○ Pressure reducing valve (PRV) rail pressure 	<ul style="list-style-type: none"> ○ Defective functionality in the system 	<ul style="list-style-type: none"> ○ Red central warning ○ Warning — Stop vehicleTurn Off Engine ○ Check — Injection system failure ○ Reduction of engine's torque ○ Limitation of engine rpm to 1100 rpm ○ Engine shut-off after 5 seconds if speed is < 2 km/h (1.2 mph)
<ul style="list-style-type: none"> ○ Monitoring transmission oil temperature 	<ul style="list-style-type: none"> ○ See 421 Hydraulic transmission, description 	<ul style="list-style-type: none"> ○ Red central warning ○ Warning — High transmission oil temp. ○ Limitation of engine rpm to 1500 rpm
<ul style="list-style-type: none"> ○ Monitoring transmission slipping 	<ul style="list-style-type: none"> ○ See 421 Hydraulic transmission, description 	<ul style="list-style-type: none"> ○ Warning — Stop vehicleTurn Off Engine ○ Check — Transmission failure ○ Limitation of engine rpm to 1500 rpm

Engine speed (engine speed for E-ECU) — Software

This function monitors boost pressure and informs the operator if there is a system malfunction.

Engine speed is used internally in the E-ECU for engine control and as input signal for engine protection.

In case of engine speed sensor malfunction, the E-ECU uses sensor SE2703 for camshaft speed instead.

See also [370 Wiring diagram 202](#)

Input signals	Conditions for output functions	Output functions
<ul style="list-style-type: none"> ○ Monitoring, SE2701 	<ul style="list-style-type: none"> ○ System malfunction, signal missing or abnormal frequency See Diagnostics 	<ul style="list-style-type: none"> ○ Amber central warning ○ Check — Engine system failure ○ Reduction of engine's torque I (engine protection)

Motor On/Off — Software

Engine On/Off is used as a condition in software functions to define when the engine is considered to be On and Off, respectively.

See also [370 Wiring diagram 201](#).

Input signals	Conditions for output functions	Output functions
<ul style="list-style-type: none"> ○ Engine speed, SE2704 	<ul style="list-style-type: none"> ○ Engine speed < 50 rpm 	<ul style="list-style-type: none"> ○ Engine = Off
	<ul style="list-style-type: none"> ○ Engine speed > 600 rpm 	<ul style="list-style-type: none"> ○ Engine = On

Automatic engine shutdown — Software

The function control engine shut-off when the conditions according to the table have been fulfilled, and informs the operator that the engine will be shut off within 1 minute. When the engine is shut off the parking brake will also be applied.

The operator can interrupt engine shutdown by affecting the throttle pedal, hand throttle, or the gear selector.

See also [370 Wiring diagram 201](#), [370 Wiring diagram 205](#), [370 Wiring diagram 404](#) and [370 Wiring diagram 408](#)

Input signals	Conditions for output functions	Output functions
<ul style="list-style-type: none"> ○ VCADS Pro parameter FAU ○ VCADS Pro parameter FAV ○ Directional gear, SW4205 ○ Throttle pedal, SE2702 APS ○ Hand throttle, SE2701 ○ Engine On/Off ○ Travel speed 	<p>Overall conditions for the function</p> <ul style="list-style-type: none"> ○ VCADS Pro parameter FAU "On" 	<ol style="list-style-type: none"> 1. Activation of the function automatic engine shut-off (4–50 min.) 2. When 1 minute remains of set time Check — AutomaticEngine shutdown is shown. [T1] ⓘ 3. Engine shutdown and parking brake is applied (MA5501 without voltage)
	<ul style="list-style-type: none"> ○ VCADS Pro parameter FAV "4–99 minutes" ○ Directional gear in position N ○ Accelerator pedal < 5% ○ Hand throttle not activated ○ Engine On ○ Travel speed < 5 km/h (3 mph) 	

[T1] Engine shutdown is interrupted in case of activation of throttle pedal, hand throttle, or if the gear selector is moved to position F or R.

Increased engine speed — Software

The function prevents reduction of engine rpm in case of high power usage.

When operating in forward or reverse, the engine speed > 850 rpm (L60–70) / 950 rpm (L90), the function is activated if the throttle pedal is let up quickly or the engine speed drops quickly.
 If the engine speed is > 1150 rpm and the function is activated, the engine speed will drop normally to 1150 rpm, then after the time delay the controlled engine speed reduction is engaged.
 When the engine speed drops to "increased engine speed" 850 rpm (L60–70) / 950 rpm (L90) (7), it will remain until the gear selector is moved to Neutral position, and controlled engine speed reduction takes place to lower idle speed.

See also [370 Wiring diagram 201](#) and [370 Wiring diagram 205](#).

Input signals	Conditions for output functions	Output functions
<ul style="list-style-type: none"> ○ Throttle pedal, SE2702 ○ Engine speed, SE2704 ○ Gear selector ○ VCADS Pro parameter, Increased engine speed (HKS) 	<ul style="list-style-type: none"> ○ VCADS Pro parameter, Increased engine speed activated <p>Activation conditions:</p> <ul style="list-style-type: none"> ○ Engine speed > 850 rpm (L60–70) / 950 rpm (L90) ○ Fast throttle pedal movement or fast engine speed reduction ○ Gear selector Forward or Reverse 	<ul style="list-style-type: none"> ○ The function Increased engine speed is activated

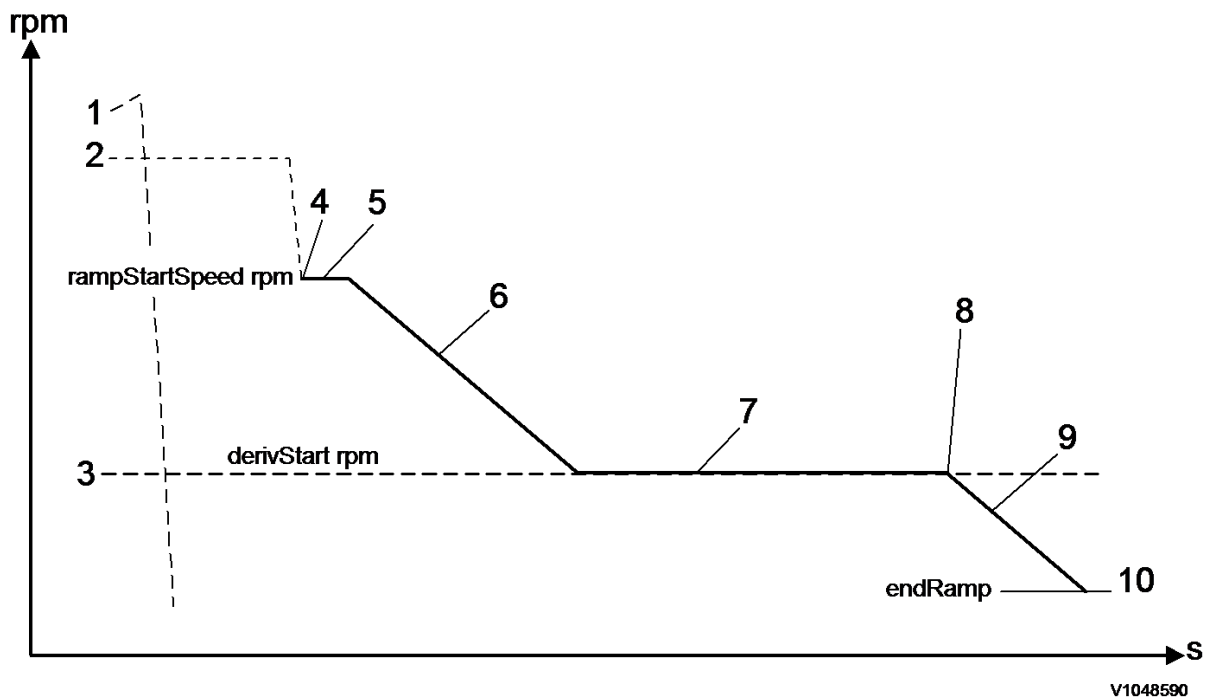

V1048590

Figure 3
Function diagram

1. Throttle pedal movement
2. Normal engine speed reduction
3. Engine speed conditions, 850 rpm (L60–70) / 950 rpm (L90)
4. Start of controlled engine speed reduction, 1150 rpm
5. Time delay before controlled engine speed reduction is activated
6. Controlled engine speed reduction
7. Increased engine speed
8. Gear selector in Neutral position
9. Controlled engine speed reduction
10. Idle speed, 700 rpm

Document Title: E-ECU, MID 128, changing non-programmed ECU	Function Group: 200	Information Type: Service Information	Date: 2014/4/1 0
Profile: WLO, L60F [GB]			

E-ECU, MID 128, changing non-programmed ECU

Op nbr 200-068

[VCADS Pro VCADS Pro Service Tool](#)

[88890180 Interface](#)

[88890027 Cable](#)

1. Place the machine in service position 1, see [191 Service position](#).
2. Connect VCADS Pro and perform the operation 28423-3 MID 128 ECU, programming.
3. Open the engine hood on the left side.
4. Unplug connectors from the E-ECU and loosen the cable harness clamps.

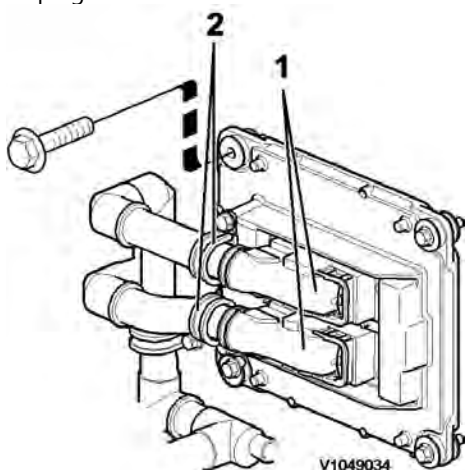

Figure 1

1. Connectors
 2. Cable harness clamps
5. Change E-ECU.
 6. Plug in the connectors for the E-ECU and install the cable harness clamps.
 7. Turn on the voltage with the battery disconnecter.
 8. Finish VCADS Pro operation 28423-3 MID 128 ECU, programming.
 9. Start the machine and check that no error messages appear.
 10. Restore the machine to operating condition.

Document Title: E-ECU, MID 128, changing pre-programmed ECU	Function Group: 200	Information Type: Service Information	Date: 2014/4/10
Profile: WLO, L60F [GB]			

E-ECU, MID 128, changing pre-programmed ECU

Op nbr 200-070

[VCADS Pro VCADS Pro Service Tool](#)

[88890180 Interface](#)

[88890027 Cable](#)

1. Place the machine in service position 1, see [191 Service position](#).
2. The new control unit has basic set parameters for the machine. If it is possible to read out customer parameters, connect VCADS Pro and perform the operation 17030-3 Parameter, programming. Save all read parameters to job card.
The operation is used to read out customer parameters from the old control unit to enable later comparison with parameters in the new control unit.
3. Open the engine hood on the left side.
4. Unplug connectors from the E-ECU and loosen the cable harness clamps.

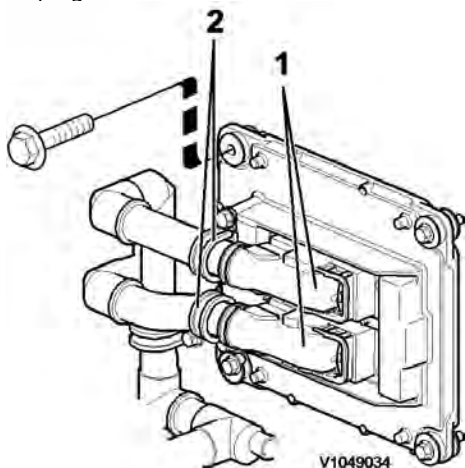

Figure 1

1. Connectors
 2. Cable harness clamps
5. Change E-ECU.
 6. Plug in the connectors for the E-ECU and install the cable harness clamps.
 7. Turn on the voltage with the battery disconnecter.
 8. If customer parameters have been read out from the old control unit, compare these to the parameters in the new control unit.

- Connect VCADS Pro and perform the operation 17030-3 Parameter, programming. Save all read parameters to job card.
- Compare parameter settings on the job cards.
- Perform operation 17030-3 Parameter, programming and change customer parameters according to job card for the old control unit.

9. Start the machine and check that no error messages appear.

10. Restore the machine to operating condition.

Thank you very much for reading.

This is part of the demo page.

GET MORE:

Hydraulic

System, Setting

Instructions, Functional

Description, Electrical

System And more.....

Click Here [BUY NOW](#)

Then Instant Download

the Complete Manual.