

Document Title: <b>Engine, removing</b>	Function Group: <b>210</b>	Information Type: <b>Service Information</b>	Date: <b>2014/4/14</b>
Profile: <b>WLO, L70F [GB]</b>			

[Go back to Index Page](#)

## Engine, removing

Op nbr 210-070

[9998547 Lifting tool](#)

Sling 1 m (3.3 ft)

Sling 3 m (9.8 ft), 2 pcs.

Lifting eyes M12, 4 pcs.

Ratchet block 750 kg (1653 lb)

Lift ring

Shackle, 4 pcs

Starter motor wrench 17 mm

1. Remove the engine hood, see [821 Engine hood, removing](#).
2. Drain the engine oil at the drain point. Volume, see: [030 Engine, capacities](#).

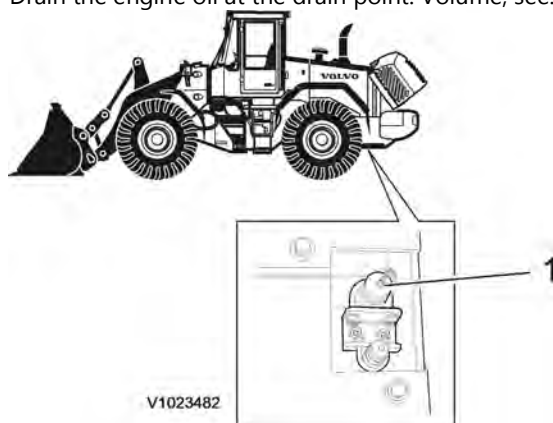

**Figure 1**

1. Drain point for engine oil
3. Disconnect the (red) electric power cable and squib cable (gas generator cable) from the control unit to deactivate the fire suppression system.

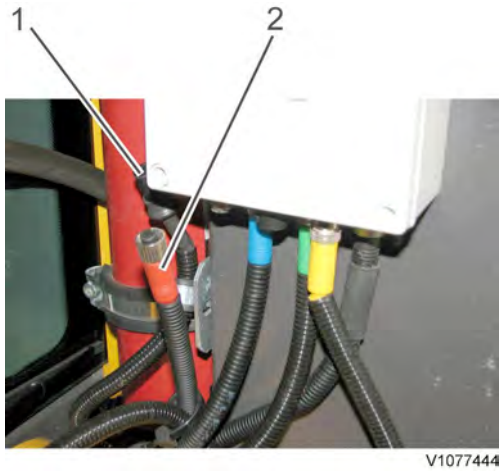

V1077444

**Figure 2**

1. Squib cable (gas generator cable)
  2. Electric power cable
4. Drain the transmission oil. Volume, hydraulic transmission, see [030 Hydraulic transmission, capacity](#)
  5. Remove the mudguards and the side panels on the hydraulic tank. Weight, fender: **approx. 30 kg (66 lbs)**.



V1041042

**Figure 3**

1. Side panel
  2. Sling 1 m
  3. Mudguard
6. Drain the hydraulic oil. Volume, hydraulic tank: see [030 Hydraulic system, volume](#)
  7. Remove the lower engine covers (3), lower grating covers (1) and the bottom plates (2) on both sides. Disconnect the ground cable (4) from the intermediate wall.

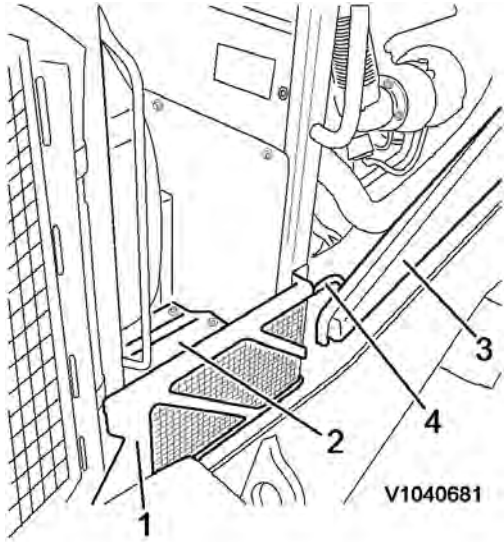

**Figure 4**

8. Disconnect the upper coolant hose from the engine and radiator.  
 Remove the bolts for the bracket for coolant pipe.  
 Disconnect the coolant hose from the engine.  
 Disconnect the hoses from the engine and intercooler.  
 Disconnect the air hose from the alternator.  
 Disconnect the clamping from the frame.

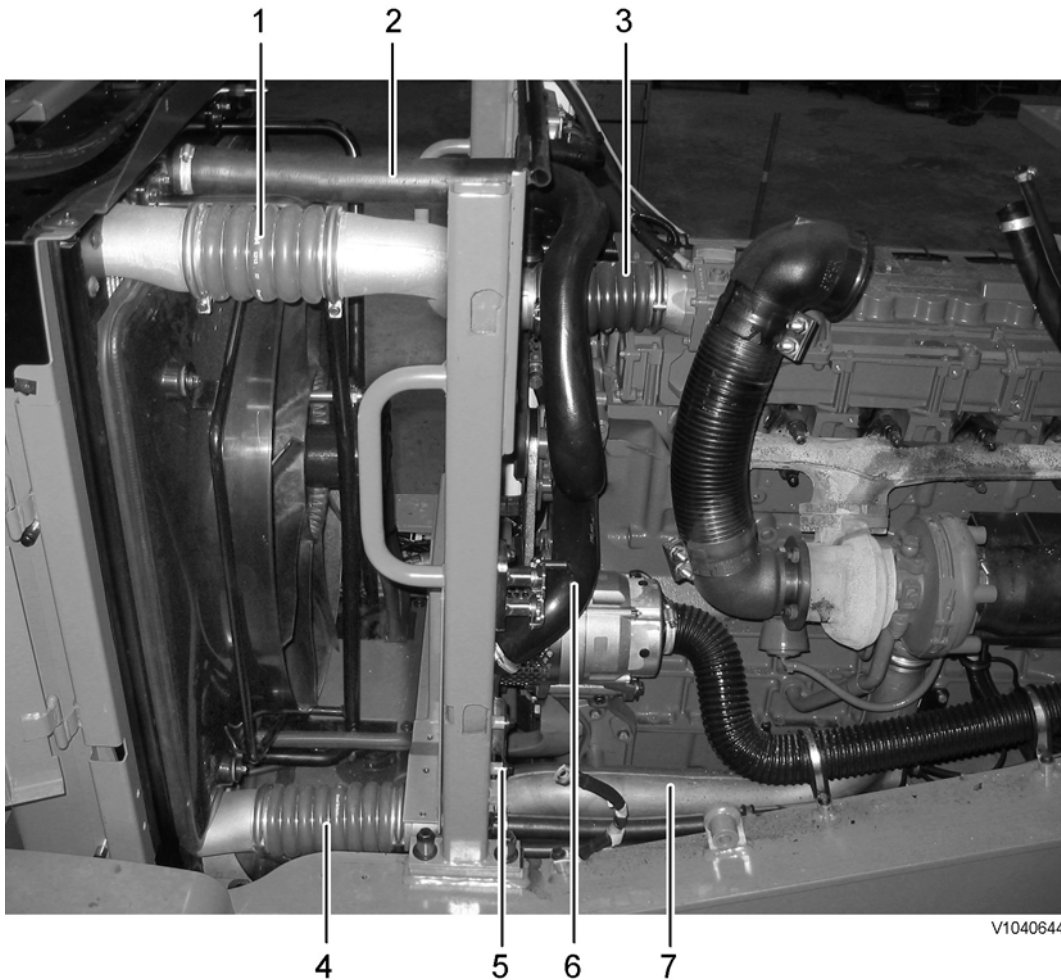

**Figure 5**

1. Charge air pipe
2. Coolant hose
3. Charge air pipe
4. Charge air pipe
5. Bracket, coolant hose
6. Coolant hose
7. Charge air pipe

## 9. NOTICE

**Refrigerant under pressure. Do not disconnect any hoses or connections on the air conditioning, thereby involuntarily releasing refrigerant.**

Unplug connector MA8701 on the AC-compressor. Remove the belt guard and loosen the belt from the AC-compressor. Disconnect the adjusting rod from the engine.

Remove the AC compressor from its bracket and lay the compressor on the wheel and the condenser on the hydraulic oil tank.

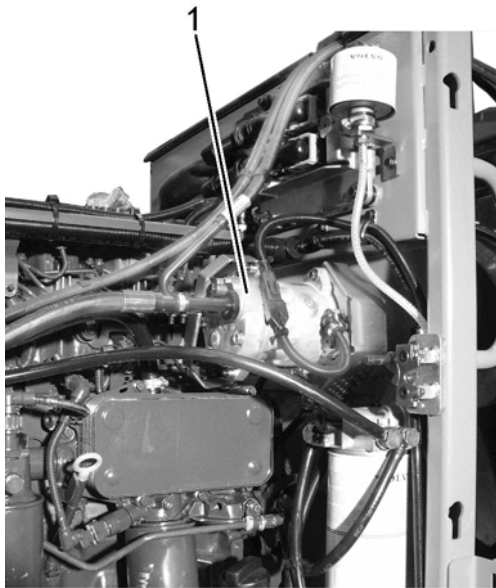

V1037002

**Figure 6**

1. AC Compressor

10. Unplug the connectors (1) for E-ECU. Disconnect the cable harness from the intermediate wall. Disconnect the hose from the air filter (2). Mark the connections for the fuel filter bracket (3). Disconnect the fuel hoses from the fuel filter bracket. Plug opened connections. Disconnect the sensor for water in fuel (SE2302).

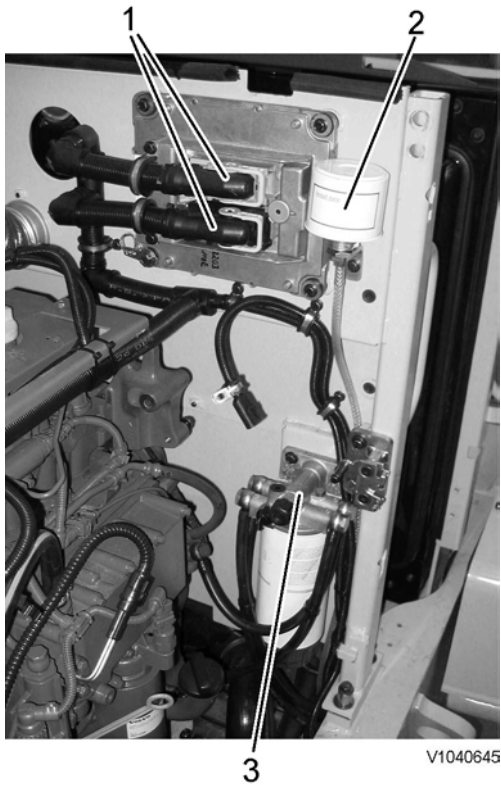

**Figure 7**

11. Secure the intermediate wall. Remove the attaching bolts on both sides. Remove the intermediate wall. Weight, intermediate wall: approx. **50 kg (110 lbs)**

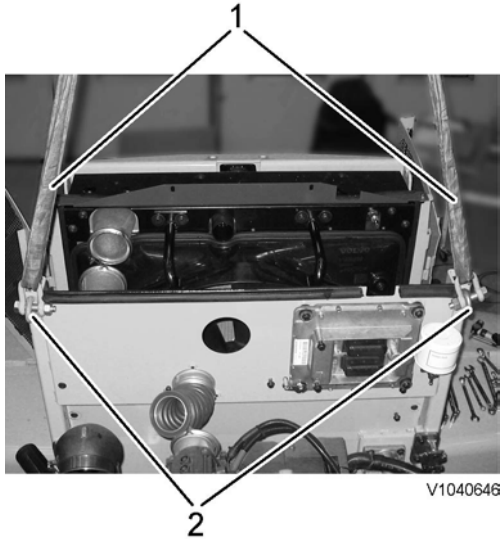

**Figure 8**

1. Sling 3 m (9.8 ft)
2. Lifting eye M12 (2 pcs.), Nut M12 (2 pcs.), Shackle (2 pcs.)

### Left side

12. Disconnect the electric connections for the preheating coil.
13. Unplug the connector for the oil level/oil temperature sensor (SE2202/2205). Disconnect the engine heater cable, if installed. Disconnect the coolant hose from the oil cooler

14. Remove the attaching clamp (1) for the AC hoses on the flywheel housing. Unplug the connector ED by lifting the catch with a screwdriver on the connector's underside and at the same time loosen the centre screw.

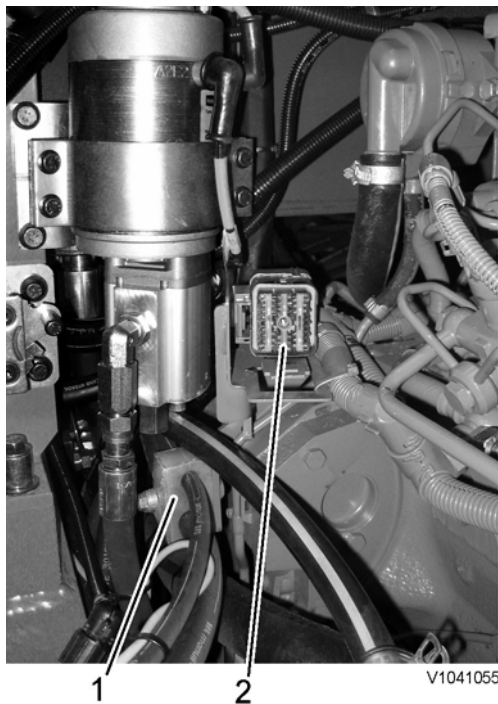

**Figure 9**

1. Attaching clamp
2. Connector ED

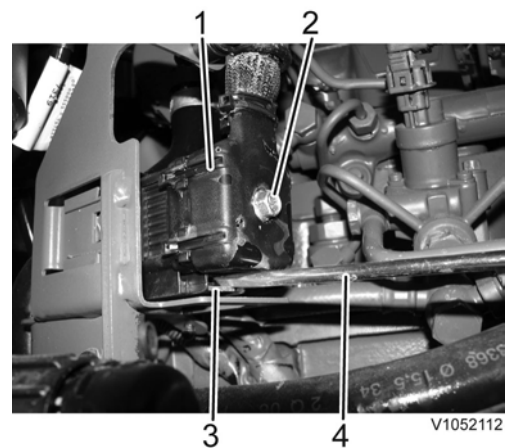

**Figure 10**

1. Connector ED
2. Centre screw
3. Bracket
4. Screwdriver

15. If the machine is equipped with reversible fan: Remove the fuel filter.
16. Disconnect the hose connections from the pump (1) and plug the connections. Remove the pump. Weight, pump: **approx. 16 kg (35 lbs).**

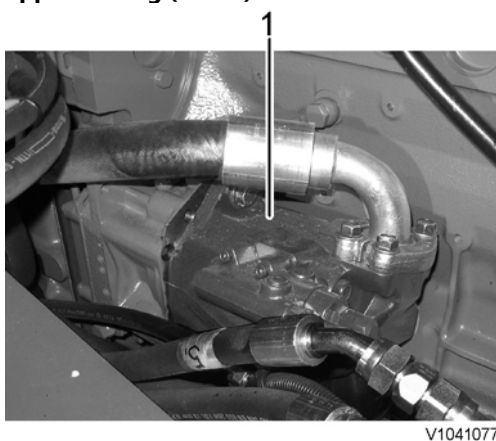
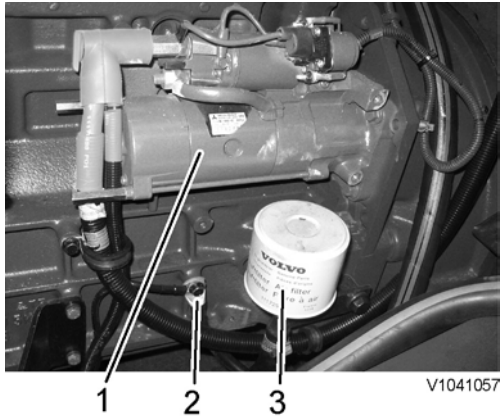

**Figure 11**

## Right side

17. Remove the alternator's rear cover. Disconnect the cable harness and air hose for the alternator.

18. Remove the starter motor's (1) protective plate. Mark and disconnect the cable harness from the starter motor and from the grounding point (2).  
Disconnect the hose from the air filter (3).

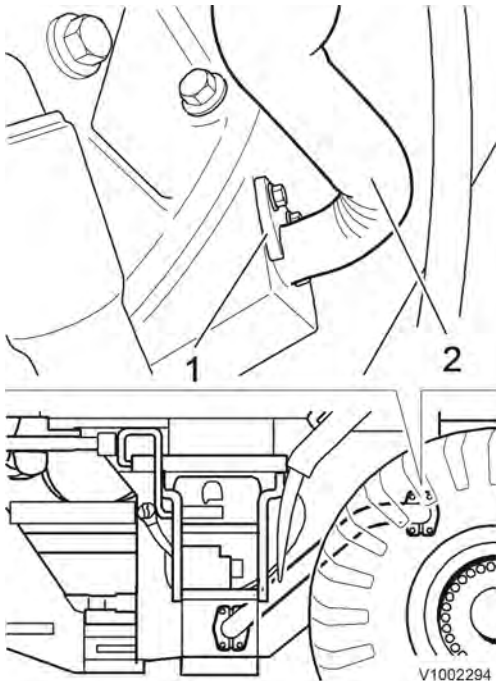

**Figure 12**

19. Remove the lower charge-air pipe.
20. Remove the front plate on the fan bracket's bottom plate.

### **Under the machine**

21. Remove the return pipe between the transmission and flywheel housing.

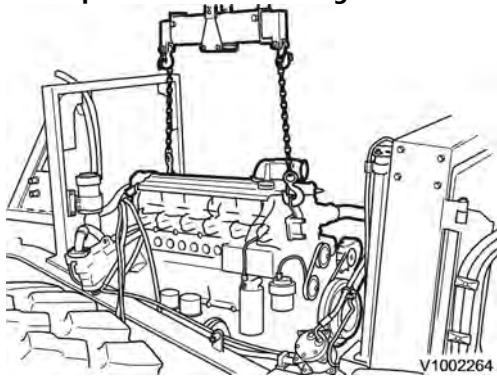

**Figure 13**

1. Mounting bracket
2. Return pipe

22. Disconnect the coolant hose in front of the engine mount.
23. Remove the brace for the engine's oil drain hose.

24. Connect the lifting device. Adjust the lifting device to the correct angle.  
**Take up the slack in the lifting device.**



**Figure 14**

1. 9998547

25. Remove the bolts for the engine mount. Turn the mount aside.

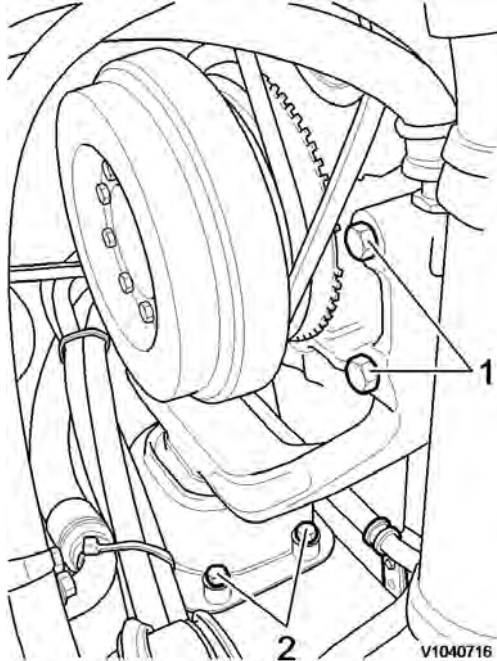
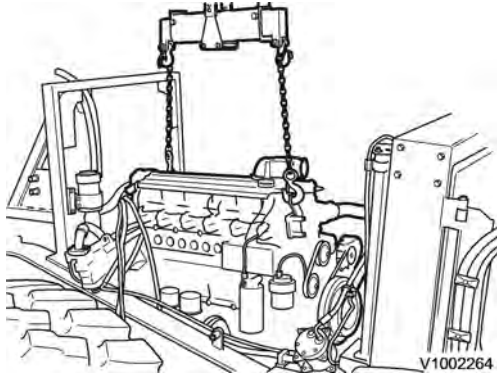

**Figure 15**

1. Attaching bolt, engine mounting  
2. Attaching bolt, engine pad

26. Lift the engine approx. 30 mm (1.2 in) and place a spacer of approx. 110 mm (4.3 in) between the transmission and the rear axle bridge. Lower until the transmission is resting on the spacer.
27. Detach the engine from the transmission.





**Figure 16**

28. Lift away the engine. Weight approx. **600 kg (1323 lbs)**.

Document Title: <b>Engine, removing</b>	Function Group: <b>210</b>	Information Type: <b>Service Information</b>	Date: <b>2014/4/14</b>
Profile: <b>WLO, L60F, L70F, L90F [GB]</b>			

[Go back to Index Page](#)

## Engine, removing

Op nbr 210-070

[9998547 Lifting tool](#)

Sling 1 m (3.3 ft)

Sling 3 m (9.8 ft), 2 pcs.

Lifting eyes M12, 4 pcs.

Ratchet block 750 kg (1653 lb)

Lift ring

Shackle, 4 pcs

Starter motor wrench 17 mm

1. Remove the engine hood, see [821 Engine hood, removing](#).
2. Drain the engine oil at the drain point. Volume, see: [030 Engine, capacities](#).

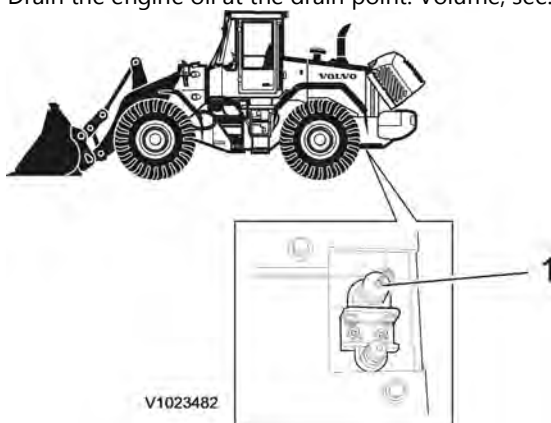

**Figure 1**

1. Drain point for engine oil
3. Drain the transmission oil. Volume, hydraulic transmission, see [030 Hydraulic transmission, capacity](#)
4. Remove the mudguards and the side panels on the hydraulic tank. Weight, fender: **approx. 30 kg (66 lbs)**.



**Figure 2**

1. Side panel
2. Sling 1 m
3. Mudguard

5. Drain the hydraulic oil. Volume, hydraulic tank: see [030 Hydraulic system, volume](#)
6. Remove the lower engine covers (3), lower grating covers (1) and the bottom plates (2) on both sides. Disconnect the ground cable (4) from the intermediate wall.

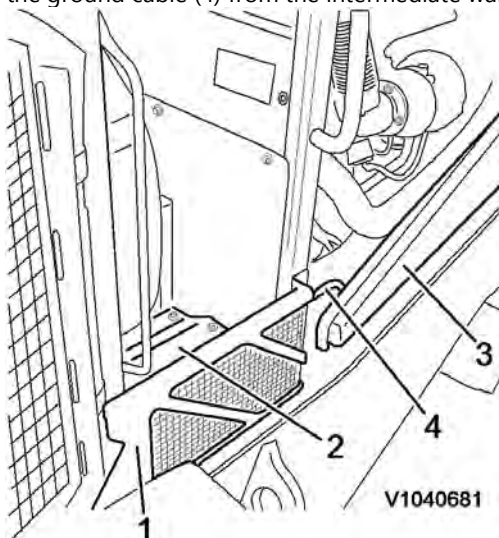

**Figure 3**

7. Disconnect the upper coolant hose from the engine and radiator. Remove the bolts for the bracket for coolant pipe.

Disconnect the coolant hose from the engine.  
Disconnect the hoses from the engine and intercooler.  
Disconnect the air hose from the alternator.  
Disconnect the clamping from the frame.

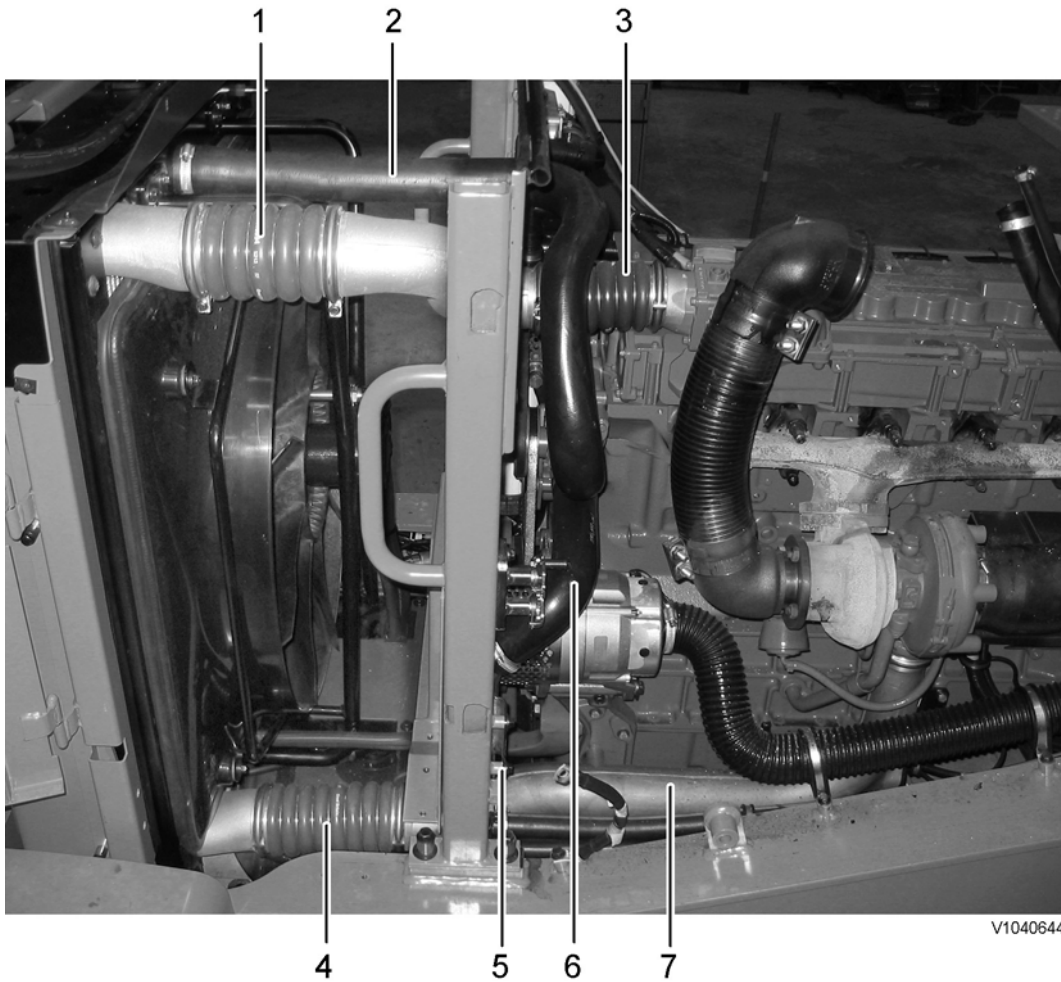
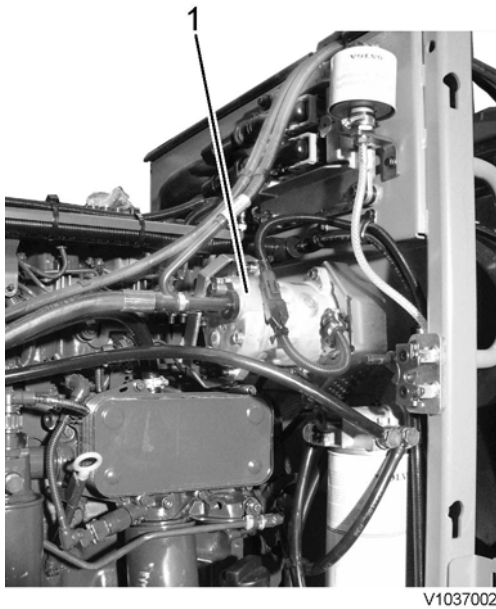

**Figure 4**

1. Charge air pipe
2. Coolant hose
3. Charge air pipe
4. Charge air pipe
5. Bracket, coolant hose
6. Coolant hose
7. Charge air pipe

8. **NOTICE**  
**Refrigerant under pressure. Do not disconnect any hoses or connections on the air conditioning, thereby involuntary releasing refrigerant.**

Unplug connector MA8701 on the AC-compressor. Remove the belt guard and loosen the belt from the AC-compressor. Disconnect the adjusting rod from the engine.  
Remove the AC compressor from its bracket and lay the compressor on the wheel and the condenser on the hydraulic oil tank.



**Figure 5**

1. AC Compressor
9. Unplug the connectors (1) for E-ECU. Disconnect the cable harness from the intermediate wall. Disconnect the hose from the air filter (2). Mark the connections for the fuel filter bracket (3). Disconnect the fuel hoses from the fuel filter bracket. Plug opened connections. Disconnect the sensor for water in fuel (SE2302).

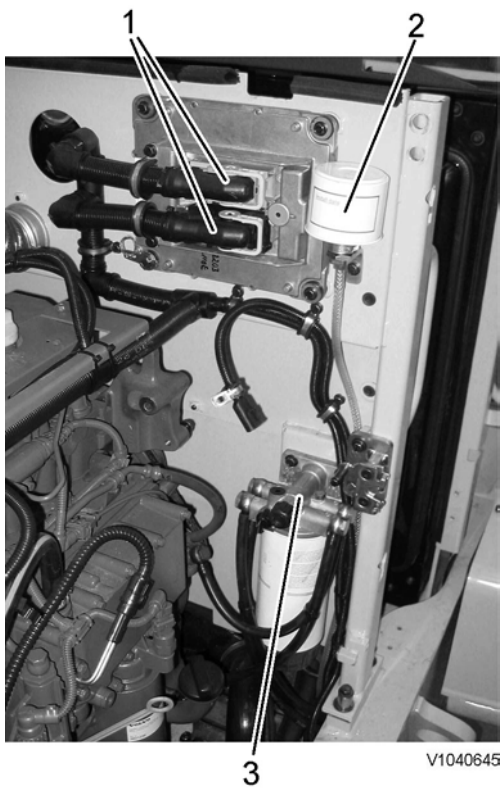

**Figure 6**

10. Secure the intermediate wall. Remove the attaching bolts on both sides. Remove the intermediate wall. Weight, intermediate wall: approx. **50 kg (110 lbs)**

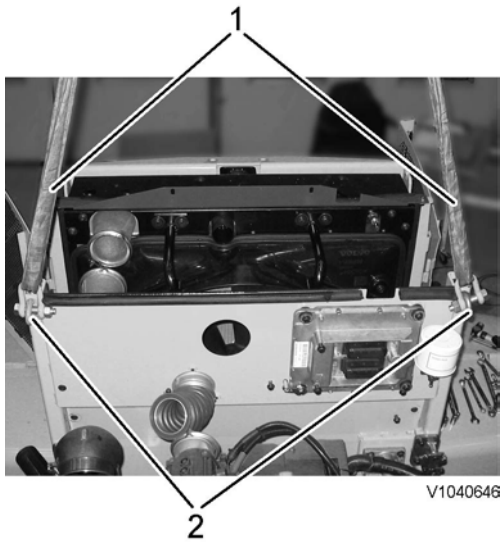
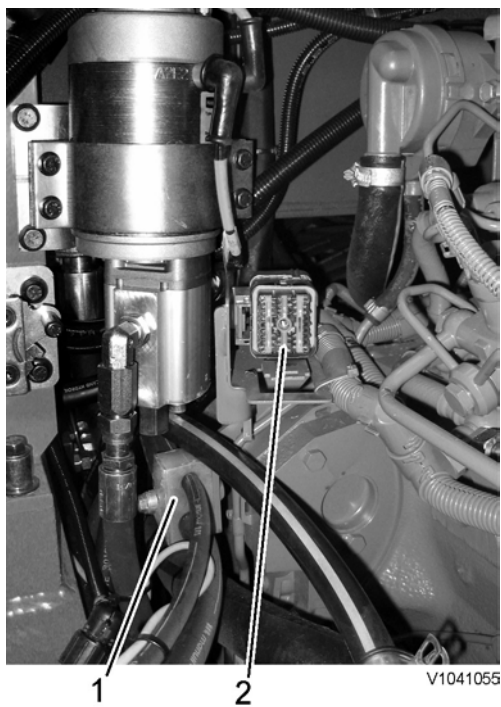

**Figure 7**

1. Sling 3 m (9.8 ft)
2. Lifting eye M12 (2 pcs.), Nut M12 (2 pcs.), Shackle (2 pcs.)

**Left side**

11. Disconnect the electric connections for the preheating coil.
12. Unplug the connector for the oil level/oil temperature sensor (SE2202/2205). Disconnect the engine heater cable, if installed. Disconnect the coolant hose from the oil cooler
13. Remove the attaching clamp (1) for the AC hoses on the flywheel housing. Unplug the connector ED by lifting the catch with a screwdriver on the connector's underside and at the same time loosen the centre screw.



**Figure 8**

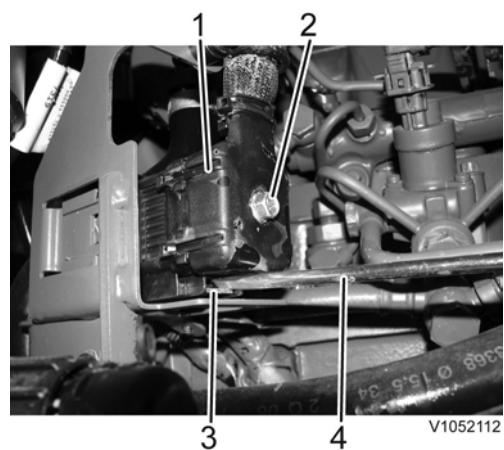

**Figure 9**

1. Connector ED
2. Centre screw
3. Mounting
4. Screwdriver

1. Attaching clamp
  2. Connector ED
- 
14. If the machine is equipped with reversible fan:  
Remove the fuel filter.
  15. Disconnect the hose connections from the pump (1) and plug the connections. Remove the pump. Weight, pump:  
**approx. 16 kg (35 lbs).**

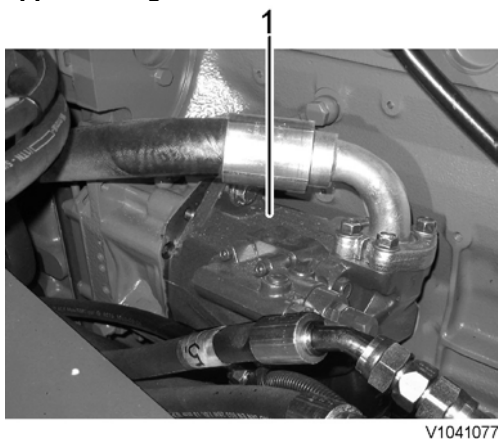

**Figure 10**

### **Right side**

16. Remove the alternator's rear cover. Disconnect the cable harness and air hose for the alternator.
17. Remove the starter motor's (1) protective plate. Mark and disconnect the cable harness from the starter motor and from the grounding point (2).  
Disconnect the hose from the air filter (3).

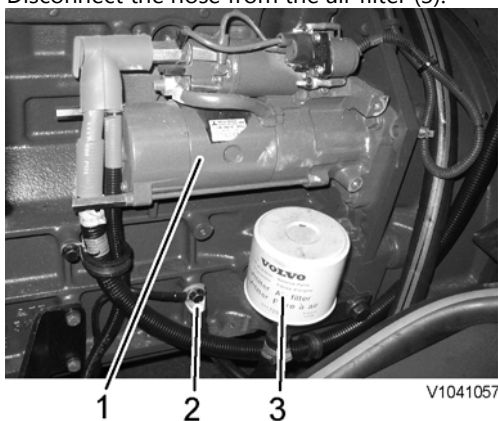
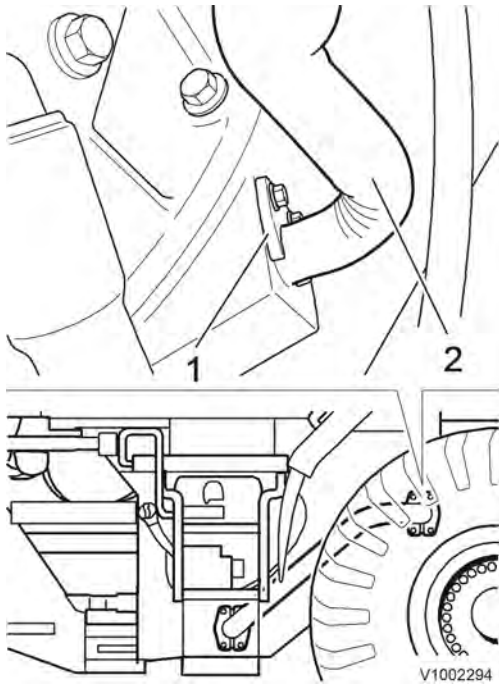

**Figure 11**

18. Remove the lower charge-air pipe.
19. Remove the front plate on the fan bracket's bottom plate.

### **Under the machine**

20. Remove the return pipe between the transmission and flywheel housing.



**Figure 12**

1. Clamp bracket
2. Return pipe

21. Disconnect the coolant hose in front of the engine mount.
22. Remove the brace for the engine's oil drain hose.
23. Connect the lifting device. Adjust the lifting device to the correct angle.  
**Take up the slack in the lifting device.**

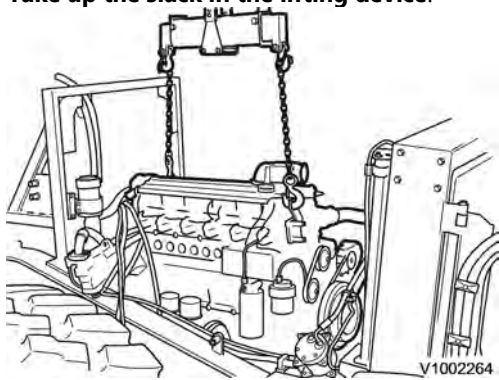
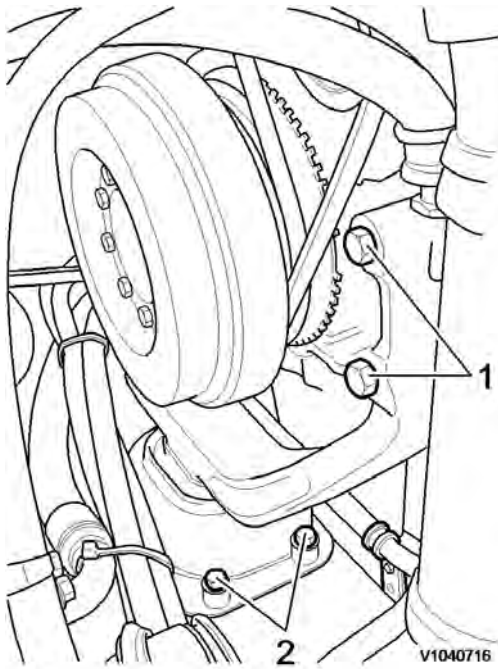

**Figure 13**

1. 9998547

24. Remove the bolts for the engine mount. Turn the mount aside.

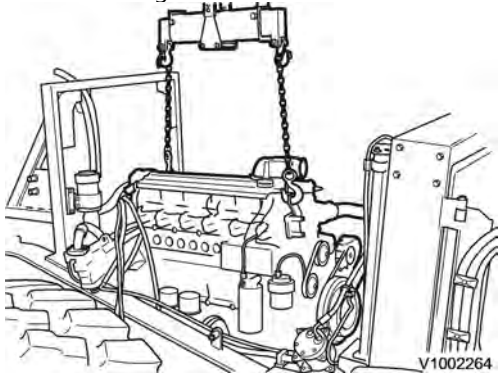



**Figure 14**

1. Attaching bolt, engine mounting
2. Attaching bolt, engine pad

25. Lift the engine approx. 30 mm (1.2 in) and place a spacer of approx. 110 mm (4.3 in) between the transmission and the rear axle bridge. Lower until the transmission is resting on the spacer.
26. Detach the engine from the transmission.



**Figure 15**

27. Lift away the engine. Weight approx. **600 kg (1323 lbs)**.

**Thank you very much for reading.**

**This is part of the demo page.**

**GET MORE:**

**Hydraulic**

**System, Setting**

**Instructions, Functional**

**Description, Electrical**

**System And more.....**

**Click Here [BUY NOW](#)**

**Then Instant Download**

**the Complete Manual.**